

IMPERX



Cheetah Pregius Cameras User Manual with GigE Vision® Interface

The Imperx Cheetah CMOS cameras provide exceptional video image quality in a remarkably compact and ruggedized design with resolutions from 2.86 to 31 MP. The cameras use Sony 2nd and 3rd generation Pregius CMOS sensors for their high sensitivity, image clarity, and high dynamic range. They achieve frame rates up to 40 frames per second with GigE Vision® output interface and support power over ethernet (PoE).

Revision 1.4

About Imperx, Inc.

IMPERX, Inc. is a leading designer and manufacturer of high performance, high quality digital cameras, frame grabbers, and accessories for industrial, commercial, military, and aerospace imaging applications including flat panel inspection, biometrics, aerial mapping, surveillance, traffic management, semiconductors and electronics, scientific & medical Imaging, printing, homeland security, space exploration, and other imaging and machine vision applications.

Fortune 100 companies, federal and state government agencies, domestic and foreign defense agencies, academic institutions, and other customers worldwide use IMPERX products.

Imperx, Inc. | 6421 Congress Ave. | Boca Raton, FL, 33487

US Phone: +1 (561) 989-0006

www.imperx.com

Warranty

IMPERX warrants performance of its products and related software to the specifications applicable at the time of sale in accordance with IMPERX's standard warranty, which is 2 (two) years parts and labor.

Do not open the housing of the camera. Warranty voids if the housing has been open or tampered.

IMPORTANT NOTICE

This camera has been tested and complies with the limits of Class A digital device, pursuant to part 15 of the FCC rules.

Copyright © 2019–2022 IMPERX Inc. All rights reserved. All information provided in this manual is believed to be accurate and reliable. No responsibility is assumed by IMPERX for its use. IMPERX reserves the right to make changes to this information without notice. Redistribution of this manual in whole or in part, by any means, is prohibited without obtaining prior permission from IMPERX. IMPERX reserves the right to make changes to its products or to discontinue any product or service without notice and advises its customers to obtain the latest version of relevant information to verify, before placing orders, that the information being relied on is current.

IMPERX PRODUCTS ARE NOT DESIGNED, INTENDED, AUTHORIZED, OR WARRANTED TO BE SUITABLE FOR USE IN LIFE-SUPPORT APPLICATIONS, DEVICES OR SYSTEMS OR OTHER CRITICAL APPLICATIONS, WHERE MALFUNCTION OF THESE PRODUCTS CAN REASONABLY BE EXPECTED TO RESULT IN PERSONAL INJURY. IMPERX CUSTOMERS USING OR SELLING THESE PRODUCTS FOR USE IN SUCH APPLICATIONS DO SO AT THEIR OWN RISK AND AGREE TO FULLY INDEMNIFY IMPERX FOR ANY DAMAGES RESULTING FROM SUCH IMPROPER USE OR SALE.



TABLE OF CONTENTS

About the Camera	11
General	11
Key Features	13
Technical Specifications	14
C1911 Camera Specifications	14
C2000 and C2400 Cameras Specifications	15
C2010 Cameras Specifications	16
C2410 Camera Specifications	17
C2410Y/Z Cameras Specifications	18
C3210 Camera Specifications	19
C4010 Cameras Specifications	20
C4110 Camera Specifications	21
C4410 Cameras Specifications	22
C5410 Cameras Specifications	23
C6410 Camera Specifications	24
C4410-T Camera Specifications	25
C5410-T Camera Specifications	26
C6410-T Camera Specifications	27
Ordering Information	28
Accessories	29
Technical Support	30
 Hardware	 31
C2000 and C2400 Cameras Connectivity	31
C2000 and C2400 Pin Assignment	32
POE-C1911, POE-C2010, POE-C2410, POE-C3210, POE-C4010 and POE-C4110 Cameras Connectivity	33
POE-C1911, POE-C2010, POE-C2410, POE-C3210, POE-C4010 and POE-C4110 Pin Assignments	34
Connecting a P-IRIS Lens	35
C4410, C5410, C6410 Cameras Connectivity	37
C4410, C5410, C6410 Pin Assignments	37
C4410-T, C5410-T, C6410-T Cameras Connectivity	38
C4410-T, C5410-T, C6410-T Pin Assignments	38
P67 Cameras Connectivity	39
IP67 Power and I/O Connector Pin Assignments	40
IP67 Ethernet Connector Pin Assignments	41
Camera LED Status Indicator	42
Powering the Camera	42
PS12V14A Power Supply	43
PS12V18A Power Supply	44
PS12V14A / PS12V18A Specifications	45
Connecting the PS12V14A / PS12V18A Power Supply	46
PS12V14A Connection Diagram	47
PS12V18A Connecting Diagram	47
Power and I/O cable CBL-COM01	48
I/O Cable CBL-PWIO01	49
IP-67 rated Power and I/O Cable CBL-IO08-0001	50
IP-67 Rated Gigabit Ethernet Cables CBL-XRJ45-00XX	51

Active Canon EF mount	52
Electrical Connectivity	53
Opto-Isolated Input.....	53
TTL/LVTTL Input	54
TTL Output	54
Opto-Isolated Output.....	55
Mechanical Drawings.....	57
C2000 and C2400 Cameras	58
POE-C1911, POE-C2010, POE-C2410, POE-C3210, POE-C4010, and POE-C4110 Cameras	61
C4410, C5410, and C6410 Cameras	64
C4410-T, C5410-T, and C6410-T Cameras.....	67
P67 Cheetah Cameras	69
IP67 C-Mount Lens Tubes (inner diameter 44 mm).....	71
IP67 C-Mount Lens Tubes (inner diameter 64 mm).....	72
IP67 Lens Tube Extension Kit	73
P67 Camera Handling Instructions.....	74
Optical.....	76
Environmental	77
GenICam™ API Module – Configuring the Camera	78
Overview	78
Camera User Set Description	78
Startup Procedure.....	78
GenApi Camera Configuration.....	79
Device Control.....	80
Version Information	82
Image Format Control.....	84
Acquisition Control	89
Gain Control	91
Auto Exposure, Auto Gain, and Auto Iris Control (AEC/AGC/AIC)	92
Data Correction.....	94
White Balance	96
Output and Strobe Signals	97
Pulse Generator	98
Canon Lens Control.....	99
P-Iris Lens Control	102
Transport Layer Information.....	103
User Set Controls	107
Event Control	108
Configuring an Ethernet Adapter and Host Computer	109
Jumbo Frames.....	110
Receive/Transmit Buffers	110
Interrupt Moderation Rate.....	110
Adjusting Jumbo Frames, Receive/Transmit Buffers, Interrupt Moderation Rate in Windows.....	112
Enabling Jumbo Frames in Linux.....	114
Adjusting Receive/Transmit Buffers in Linux	115
Configuring a Host Computer in Windows	116
Disabling Windows Firewall for All Connections.....	117
Disabling Windows Firewall for Selected Network Adapters	118

Configuring IP Addresses	120
Configuring a Static IP Address in Windows	120
Configuring a Static IP Address in Linux	122
Configuring an IP Address Using DHCP in Windows	123
Configuring an IP Address Using DHCP in Linux	125
Link-Local IP Address	126
Configuring a Link-Local Address in Linux	126
Configuring a Persistent IP Address for a Camera	128
Configuring Power Management in Windows	130
Enabling Imperx Filter Driver in Windows	132
Camera's UDP Ports	134
Software GUI	135
Overview	135
Supported Operating Systems	135
Compatibility	136
User Interface and Functionality	136
Installing the Software in Windows	136
Installation	137
Installing the Software in Linux	141
Camera SDK	143
Connecting to Cameras	144
Using the IpxPlayer	146
Menu Bar	146
Camera Parameters Panel	148
Device Control Category	148
Version Info Category	149
Image Format Control Category	150
Acquisition Control Category	152
Gain Control Category	155
Auto Gain, Exposure, and Iris Category	156
Data Correction Controls Category	159
White Balance Category	160
Strobe Category	161
Pulse Generator Category	162
Canon Lens Control Category	163
P-Iris Lens Control Category	166
Transport Layer Control Category	167
User Set Control Category	169
Event Control Category	169
Capture Panel	170
Recording Acquired Images	170
Saving Image Output	170
Saving Image in AVI Movie File Format	171
Log Panel	172
Channels to Log	172
Statistics Panel	173
Camera Terminal Panel	174
Uploading Files	174
Downloading Files	174
Histogram Panel	176
Mean/StdDev Pane	176

Visualization Pane	177
Hex Pixel Dump Panel	179
Camera Features	180
Image Data Flow	180
Exposure Control	181
Exposure Control in Free-Running Mode	181
Exposure Control in Trigger Mode	185
Global Shutter	187
Automatic Exposure Control	188
Automatic Gain Control	189
Automatic Iris Control	190
Acquisition Control	193
Gain and Offset	194
Image Sensor's Analog and Digital Gain	194
Digital Gain	194
Digital Offset	194
Black Level Auto-Calibration and Offset	195
Data Output Format	195
Pulse Generator	196
Input / Output Control	196
Camera Triggering	198
Standard Trigger Mode	198
Fast Trigger Mode	201
Trigger Sources	202
Configuring the Trigger	203
Strobe and Synchronization Controls	205
Configuring the Strobe	206
Area of Interest	207
Horizontal and Vertical Window	207
Factors Impacting Frame Rate	207
Slave AOI	208
Binning and Sub-Sampling Decimation	209
Binning	209
Sub-Sampling Decimation	210
Transfer Function Correction	211
Bad Pixel Correction	212
Flat Field Correction	212
Test Image Pattern	213
Color Control	215
Canon Lens Control	216
Focus Control	216
Iris Control	217
Configuration Memory	218
Image Sensor Technology	219
General Information	219
Spectral Sensitivity	220
Micro-polarized Cameras	220
Appendix A: Spectral Response	221
Cheetah C1911 Spectral Response	221

Cheetah C2000 and C2010 Spectral Response	222
Cheetah C2400 and C2410 Spectral Response	223
Cheetah C2410Y/Z Spectral Response.....	224
Cheetah C3210 Spectral Response	225
Cheetah C4010 Spectral Response	226
Cheetah C4110 Spectral Response	227
Cheetah C4410 Spectral Response	228
Cheetah C5410 Spectral Response	229
Cheetah C6410 Spectral Response	230
Appendix B: Creating Bad Pixel Correction Maps.....	231
Overview	231
Editing BPM Files	231
Finding Bad Pixels	232
Locating and adding pixel coordinates	233
Creating a BPM Using a Text Editor	236
Creating a BPM Using Imperx Toolkit	237
Uploading a BPM File.....	238
Appendix C: Look Up Tables.....	240
Creating an LUT Using a Text Editor	240
Creating an LUT Using Microsoft Excel.....	241
Creating an LUT Using Imperx Toolkit	242
Uploading the LUT File.....	246

REVISION HISTORY

Revision	Date	Reviser	Comments
1.0	8/27/2019	K. Wetzel I. Barabanova	Initial release.
1.1	11/27/2019	I. Barabanova	Added POE-C1911 and P67-C1911 cameras Added Accessories section Added p/n of IP67 lens tubes and cables Added mounting plates drawings Updated P67 camera drawings Added IP67 lens tubes drawings Added IP67 cables drawings Added Network Adapter adjustment procedures
1.2	1/03/2020	I. Barabanova	Removed logos
1.3	01/08/2021	I. Barabanova	Added binning and sub-sampling Added Canon Lens Control (XML parameters, GUI screens, adjusting procedures) Added P-IRIS pin assignments, XML parameters Added POE-C4410-T, POE-C5410-T, POE-C6410-T cameras (specification tables, ordering information, mechanical drawings) Added Ubuntu Linux 18.04 64bit and Ubuntu Linux 18.04 64-bit, ARM CPU. Deleted the <i>TriggerFilter</i> and dynamic <i>BadPixelCorrection</i> features. Added new sections: Image Data Flow, Exposure Control in Free-Running and Trigger Modes, Input/Output Control, Fast/Standard Trigger Modes, Configuring the trigger, Configuring the Strobe, Transfer Function Correction Updated C4410, C5410, C6410 mechanical drawings. Adjusted voltage range of the opto-isolated output. Added new Power Supply PS12V14A.
1.4	2/14/2022	I. Barabanova	Added Ethernet Adapter Configuration procedures for Linux OS. Added Filter Driver. Added Camera SDK installation in Linux. Added new Power Supply PS12V18A. Added a connection diagram in the Connecting a P-IRIS Lens section. Updated mechanical drawings for C1911, C2010, C2410, C3210, C4010, C4110 cameras Added MTBF specification

ADDITIONAL RESOURCES

Name of the document	Description	Where to find
Cheetah Pregius POE 10G SFP CXP QuickStart	The Quick Start provides software installation steps for the Cheetah GigE Vision® w/PoE cameras.	Cheetah POE/P67 ZIP archive
Cheetah P67 Assembly Guide	The Assembly Guide describes how to assemble a Cheetah P67 camera, including a lens and IP67 lens tube installation and cleaning the camera’s protective glass.	Or
Cheetah IP67 Lens Tube Extension Kit QuickStart	The Quick Start describes how to extend an Imperx IP67 lens tube using an Imperx extension kit.	Imperx Subscriber Area (registration required)
Imperx Sensor Cleaning Procedure	The Sensor Cleaning Procedure provides instructions on cleaning an image sensor.	
ANP06 Cheetah POE P-IRIS Lens Control Application Note	The Application Note describes how to control an iris position of a P-Iris lens in the Imperx Cheetah GigE Vision® with PoE cameras.	
Ethernet Adapter Configuration Guide (Windows 10 OS)	The Ethernet Adapter Configuration Guide describes how to adjust your Ethernet adapter and set IP addresses for NICs and Imperx GigE Vision® cameras when working with Windows 10 OS	
Ethernet Adapter Configuration Guide (Linux OS)	The Ethernet Adapter Configuration Guide describes how to adjust your Ethernet adapter and set IP addresses for NICs and Imperx GigE Vision® cameras when working with Linux OS	
ANP12 Canon EF EOS Lens Control Application Note	The Application Note describes how to control a Canon EF EOS lens in the Imperx Cheetah cameras	

About the Camera

General

The GigE Vision® with Power over Ethernet (PoE) Cheetah CMOS cameras are built around advanced Sony Pregius CMOS image sensors with global shutter for high quality images in a small ruggedized form factor. Cheetah cameras are progressive scan digital cameras featuring a built-in image-processing engine, low power consumption, low noise, and high dynamic range (71 dB).

The cameras provide several trigger modes and output strobes allowing you to synchronize the image capture of one or more cameras to an external event. They also provide an Area of Interest (AOI), programmable look-up tables (LUT) and the ability to store up to four different camera configurations. Using the simple GenICam™ compliant user interface, you can quickly apply image corrections to enhance recognition or quality.

The cameras are suitable for a wide range of environmental conditions and applications, such as machine vision, industrial inspection, surveillance, aerospace, and more.

The C2000 and C2400 cameras are ultra-compact with a slimmed down feature set for cost-sensitive applications.

The C1911 and C3210 camera have large 4.5-micron square pixels for improved sensitivity and dynamic range.

The Cheetah P67 cameras feature IP67-rated enclosure that protects a camera from ingress of water, dirt, dust, sand, and other contaminants and can be utilized in harsh environments. Imperx offers IP67 lens tubes of different diameters to be used with varying lens sizes to suit your specific requirements.

The C4410, C5410, and C6410 cameras feature 20 MP, 17 MP, and 31 MP Sony Pregius CMOS sensors respectively, provide support for active Canon EOS lens with iris and focus controls.

The C4410-T, C5410-T, and C6410-T cameras feature thermoelectric Peltier cooling module (TEC) that stabilizes the sensor temperature to a certain level reducing thermal noise and improving measurement precision. Built-in forced air-cooling is available.

The C2410Y/Z camera features micro-polarized Sony Pregius CMOS sensors. The sensors have a 2x2 pixel sub-array where each pixel within the sub-array blocks a different polarization angle (0, 45, 90 or 135 degrees).

The cameras ship with the Imperx SDK and IpxPlayer for playing/recording videos and setting camera features.

The cameras use global shutter operation for superior motion capture with exceptionally high frame rates for high throughput applications. You can synchronize the cameras to an external trigger source and vary exposure times using internal controls or an external pulse width. An Area of Interest (AOI) can be programmed for each acquisition frame.

Built-in gamma correction and user-defined look-up table (LUT) capabilities optimize the camera's dynamic range features. Bad pixel correction is used for pixels that are over-responding or under-responding. Auto White Balance (AWB) is available in color cameras to correct for color temperature.

Camera Model	Resolution (MP)	Resolution (H x V)	Frame Rate (Max)	Type (Color/ Mono)	Optical format	Pixel Size (microns)	Sony Sensor Model
POE-C1911	2.86	1944 x 1472	40	C, M	2/3"	4.5	IMX429
P67-C1911	2.86	1944 x 1472	40	C, M	2/3"	4.5	IMX429
POE-C2000	3	2064 x 1544	36	C, M	1/1.8"	3.45	IMX265
POE-C2010	3	2064 x 1544	36	C, M	1/1.8"	3.45	IMX265
P67-C2010	3	2064 x 1544	36	C, M	1/1.8"	3.45	IMX265
POE-C2400	5	2464 x 2056	22	C, M	2/3"	3.45	IMX264
POE-C2410	5	2464 x 2056	22	C, M	2/3"	3.45	IMX264
POE-C2410Y/Z	5	2464 x 2056	22	Y, Z	2/3"	3.45	IMX250MY/ZR
P67-C2410	5	2464 x 2056	22	C, M	2/3"	3.45	IMX264
POE-C3210	7	3216 x 2208	16	C, M	1.1"	4.5	IMX428
P67-C3210	7	3216 x 2208	16	C, M	1.1"	4.5	IMX428
POE-C4010	9	4112 x 2176	13	C, M	1"	3.45	IMX267
P67-C4010	9	4112 x 2176	13	C, M	1"	3.45	IMX267
POE-C4110	12	4112 x 3008	9	C, M	1.1"	3.45	IMX304
P67-C4110	12	4112 x 3008	9	C, M	1.1"	3.45	IMX304
POE-C4410	20	4432 x 4436	6	C, M	4/3"	3.45	IMX367
POE-C4410-T	20	4432 x 4436	6	C, M	4/3"	3.45	IMX367
POE-C5410	17	5472 x 3084	7	C, M	4/3"	3.45	IMX387
POE-C5410-T	17	5472 x 3084	7	C, M	4/3"	3.45	IMX387
POE-C6410	31	6480 x 4860	3.7	C, M	APS-C	3.45	IMX342
POE-C6410-T	31	6480 x 4860	3.7	C, M	APS-C	3.45	IMX342

Key Features

- Global shutter (GS)
- Color and monochrome versions
- Fast frame rates
- High data transfer rates up to 930 megabits per second
- Uses CAT5e or CAT6 cables and standard RJ45 connectors (exception: P67 cameras)
- Data transfer up to 100 meters in length
- Internal, external exposure controls
- Automatic exposure and gain control (AEC/AGC) (exception: C2000 and C2400)
- Analog and digital gain control
- Offset control
- Built-in pulse generator
- Area of interest (AOI)
- Programmable external inputs and outputs
- Multiple Trigger/Synchronization options
- Automatic and manual white balance
- Four 12-bit look-up tables (LUT)
- Bad pixel correction, user-defined and factory
- Flat field correction, user defined and factory (exception: C2000)
- Dynamic transfer function and gamma corrections
- Optional P-Iris (exception: C4410, C5410, C6410, C4410-T, C5410-T, C6410-T, C2000, C2400, and P67 cameras)
- Canon EOS EF lens control (C4410, C5410, C6410, C4410-T, C5410-T, and C6410-T cameras only)
- Thermoelectric cooling (TEC) (C4410-T, C5410-T, and C6410-T cameras only)
- Temperature monitor
- Field upgradeable firmware

Technical Specifications

C1911 Camera Specifications

Specifications	POE-C1911, P67-C1911 (2.86 MP)	
Active image resolution	1944 (H) x 1472 (V)	
Pixel size	4.5 μm	
Optical format	2/3 inch	
Shutter	Global	
Frame rate (max)	40 fps (8-bit), 20 fps (10, 12-bit unpacked), 26 fps (10, 12-bit packed)	
Sensor digitization	12-bit	
Dynamic range	77 dB	
Output bit depth	8, 10, or 12-bit	
Shutter speed	21 μs to 16.0 s	
Analog / Digital gain	Manual, auto; 0–48 dB (0.1 dB step)	
Digital gain	1x (0 dB) to 4x (12 dB), 0.001x step	
AEC/AGC	Yes	
Black level offset	Manual (0–4095), auto	
Exposure control	Manual, auto, external, off	
White balance	Once, manual, auto, off	
Area of interest (AOI)	Two	
Binning	1x2, 2x1, 2x2 (available in monochrome cameras only)	
Sub-sampling	1x2, 2x1, 2x2	
Trigger inputs	External, pulse generator, software	
Trigger options	Edge, pulse width, trigger delay, debounce	
Trigger modes	Free-run, standard, fast	
I/O control	POE	2 IN (OPTO, LVTTTL) / 2 OUT (OPTO, TTL)
	P67	1 IN (OPTO) / 2 OUT (OPTO, TTL)
Strobe output	2 strobes, programmable position and duration	
Pulse generator	Yes, programmable	
Lens mount	POE	C-mount (default), P-Iris (optional)
	P67	C-mount (default)
Camera housing	6000 series aluminum	
Upgradeable firmware	Yes	
Data correction	4 LUTs: pre-programmed with Gamma 0.45 and negative LUT, flat field correction, bad pixel correction (static)	
Supply voltage range	12 VDC (6 V–30 V), 1.5 A inrush @ 12 V; PoE (IEEE 802.3af/IEEE 802.3at)	
Power consumption	Typical: 3.84 W @ 12 V; PoE: 5.18 W	
Camera size (W x H x L)	POE	37 x 37 x 61.6 mm
	P67	48.5 x 42 x 61 mm (without a lens tube)
Weight	POE	125.2 grams
	P67	196 grams (without lens tube)
Vibration, shock	20G (20–200 Hz XYZ) / 100G	
Environmental	Operating	-30 °C to +75 °C (-40 °C to +85 °C tested)
	Storage	-40 °C to +85 °C
Relative humidity	10% to 90% non-condensing	
Regulatory	FCC part 15 Class A, CE, RoHS, UKCA	
MTBF	POE	530,000 hours @ 50 °C (EST) (Telcordia SR-332)
	P67	550,000 hours @ 50 °C (EST) (Telcordia SR-332)

C2000 and C2400 Cameras Specifications

Specifications	C2000 (3 MP)	C2400 (5 MP)
Active image resolution	2064 (H) x 1544 (V)	2464 (H) x 2056 (V)
Pixel size	3.45 μm	3.45 μm
Optical format	1/1.8 inch	2/3 inch
Shutter	Global	Global
Frame rate (max)	36 fps (8-bit), 18 fps (10, 12-bit unpacked), 24 fps (10, 12-bit packed)	22 fps (8-bit), 11 fps (10, 12-bit unpacked), 15 fps (10, 12-bit packed)
Sensor digitization	12-bit	12-bit
Dynamic range	71 dB	71 dB
Output bit depth	8, 10, or 12-bit	8, 10, or 12-bit
Shutter speed	31 μs to 16.0 s	35 μs to 16.0 s
Analog / Digital gain	0–48 dB (0.1 dB step)	0–48 dB (0.1 dB step)
Digital gain	1x (0 dB) to 4x (12 dB), 0.001x step	1x (0 dB) to 4x (12 dB), 0.001x step
Black level offset	Manual (0–4095), auto	Manual (0–4095), auto
Exposure control	Manual, external, off	Manual, external, off
White balance	Once, manual, auto, off	Once, manual, auto, off
Area of interest (AOI)	One	One
Trigger inputs	External, pulse generator, software	External, pulse generator, software
Trigger options	Edge, pulse width, trigger delay, debounce	Edge, pulse width, trigger delay, debounce
Trigger modes	Free-run, standard, fast	Free-run, standard, fast
I/O control	1 IN (OPTO) / 1 OUT (OPTO)	1 IN (OPTO) / 1 OUT (OPTO)
Strobe output	1 strobe, programmable position and duration	1 strobe, programmable position and duration
Pulse generator	Yes, programmable	Yes, programmable
Lens mount	C-mount (default)	C-mount (default)
Camera housing	6000 series aluminum	6000 series aluminum
Upgradeable firmware	Yes	Yes
Data correction	4 LUTs: pre-programmed with Gamma 0.45 and negative LUT, flat field correction, bad pixel correction (static)	4 LUTs: pre-programmed with Gamma 0.45 and negative LUT, flat field correction, bad pixel correction (static)
Supply voltage range	12 VDC (6 V–30 V), 1.5 A inrush @ 12 V; PoE (IEEE 802.3af/IEEE 802.3at)	12 VDC (6 V–30 V), 1.5 A inrush @ 12 V; PoE (IEEE 802.3af/IEEE 802.3at)
Power consumption	Typical: 3.72 W @ 12 V; PoE: 5 W	Typical: 3.48 W @ 12 V; PoE: 4.96 W
Camera size (W x H x L)	29 x 29 x 59.4 mm	29 x 29 x 59.4 mm
Weight	77.6 grams	77.6 grams
Vibration, shock	30G (20–200 Hz XYZ) / 500G	30G (20–200 Hz XYZ) / 500G
Environmental	Operating	-30 °C to +70 °C
	Storage	-40 °C to +85 °C
Relative humidity	10% to 90% non-condensing	10% to 90% non-condensing
Regulatory	FCC part 15, CE, RoHS, UKCA	FCC part 15, CE, RoHS, UKCA
MTBF	550,000 hours @ 50 °C (EST)	550,000 hours @ 50 °C (EST)

C2010 Cameras Specifications

Specifications	POE-C2010, P67-C2010 (3 MP)	
Active image resolution	2064 (H) x 1544 (V)	
Pixel size	3.45 µm	
Optical format	1/1.8 inch	
Shutter	Global	
Frame rate (max)	36 fps (8-bit), 18 fps (10, 12-bit unpacked), 24 fps (10, 12-bit packed)	
Sensor digitization	12-bit	
Dynamic range	71 dB	
Output bit depth	8, 10, or 12-bit	
Shutter speed	31 µs to 16.0 s	
Analog / Digital gain	Manual, auto; 0–48 dB (0.1 dB step)	
Digital gain	1x (0 dB) to 4x (12 dB), 0.001x step	
AEC/AGC	Yes	
Black level offset	Manual (0–4095), auto	
Exposure control	Manual, auto, external, off	
White balance	Once, manual, auto, off	
Area of interest (AOI)	Two	
Sub-sampling	1x2, 2x1, 2x2	
Trigger inputs	External, pulse generator, software	
Trigger options	Edge, pulse width, trigger delay, debounce	
Trigger modes	Free-run, standard, fast	
I/O control	POE	2 IN (OPTO, LVTTTL) / 2 OUT (OPTO, TTL)
	P67	1 IN (OPTO) / 2 OUT (OPTO, TTL)
Strobe output	2 strobes, programmable position and duration	
Pulse generator	Yes, programmable	
Lens mount	POE	C-mount (default), P-Iris (optional)
	P67	C-mount (default)
Camera housing	6000 series aluminum	
Upgradeable firmware	Yes	
Data correction	4 LUTs: pre-programmed with Gamma 0.45 and negative LUT, flat field correction, bad pixel correction (static)	
Supply voltage range	12 VDC (6 V–30 V), 1.5 A inrush @ 12 V; PoE (IEEE 802.3af/IEEE 802.3at)	
Power consumption	Typical: 3 W @ 12 V; PoE: 4.64 W	
Camera size (W x H x L)	POE	37 x 37 x 61.6 mm
	P67	48.5 x 42 x 61 mm (without lens tube)
Weight	POE	125.2 grams
	P67	196 grams (without lens tube)
Vibration, shock	20G (20–200 Hz XYZ) / 100G	
Environmental	Operating	-30 °C to +75 °C (-40 °C to +85 °C tested)
	Storage	-40 °C to +85 °C
Relative humidity	10% to 90% non-condensing	
Regulatory	FCC part 15 Class A, CE, RoHS, UKCA	
MTBF	POE	530,000 hours @ 50 °C (EST) (Telcordia SR-332)
	P67	550,000 hours @ 50 °C (EST) (Telcordia SR-332)

C2410 Camera Specifications

Specifications	POE-C2410, P67-C2410 (5 MP)	
Active image resolution	2464 (H) x 2056 (V)	
Pixel size	3.45 µm	
Optical format	2/3 inch	
Shutter	Global	
Frame rate (max)	22 fps (8-bit), 11 fps (10, 12-bit unpacked), 15 fps (10, 12-bit packed)	
Sensor digitization	12-bit	
Dynamic range	71 dB	
Output bit depth	8, 10, or 12-bit	
Shutter speed	35 µs to 16.0 s	
Analog / Digital gain	Manual, auto; 0–48 dB (0.1 dB step)	
Digital gain	1x (0 dB) to 4x (12 dB), 0.001x step	
AEC/AGC	Yes	
Black level offset	Manual (0–4095), auto	
Exposure control	Manual, auto, external, off	
White balance	Once, manual, auto, off	
Area of interest (AOI)	Two	
Sub-sampling	1x2, 2x1, 2x2	
Trigger inputs	External, pulse generator, software	
Trigger options	Edge, pulse width, trigger delay, debounce	
Trigger modes	Free-run, standard, fast	
I/O control	POE	2 IN (OPTO, LVTTTL) / 2 OUT (OPTO, TTL)
	P67	1 IN (OPTO) / 2 OUT (OPTO, TTL)
Strobe output	2 strobes, programmable position and duration	
Pulse generator	Yes, programmable	
Lens mount	POE	C-mount (default), P-Iris (optional)
	P67	C-mount (default)
Camera housing	6000 series aluminum	
Upgradeable firmware	Yes	
Data correction	4 LUTs: pre-programmed with Gamma 0.45 and negative LUT, flat field correction, bad pixel correction (static)	
Supply voltage range	12 VDC (6 V–30 V), 1.5 A inrush @ 12 V; PoE (IEEE 802.3af/IEEE 802.3at)	
Power consumption	Typical: 3.24 W @ 12 V; PoE: 4.69 W	
Camera size (W x H x L)	POE	37 x 37 x 61.6 mm
	P67	48.5 x 42 x 61 mm (without a lens tube)
Weight	POE	125.2 grams
	P67	196 grams (without lens tube)
Vibration, shock	20G (20–200 Hz XYZ) / 100G	
Environmental	Operating	-30 °C to +75 °C (-40 °C to +85 °C tested)
	Storage	-40 °C to +85 °C
Relative humidity	10% to 90% non-condensing	
Regulatory	FCC part 15 Class A, CE, RoHS, UKCA	
MTBF	POE	530,000 hours @ 50 °C (EST) (Telcordia SR-332)
	P67	550,000 hours @ 50 °C (EST) (Telcordia SR-332)

C2410Y/Z Cameras Specifications

Specifications	POE-C2410Y/Z (5 MP)
Active image resolution	2464 (H) x 2056 (V) 1232 (H) x 1028 (V) per polarization angle
Pixel size	3.45 μm
Optical format	2/3 inch
Shutter	Global
Frame rate (max)	22 fps (8-bit), 11 fps (10, 12-bit unpacked), 15 fps (10, 12-bit packed)
Sensor digitization	12-bit
Dynamic range	71 dB
Output bit depth	8, 10, or 12-bit
Shutter speed	35 μs to 16.0 s
Analog / Digital gain	Manual, auto; 0–48 dB (0.1 dB step)
Digital gain	1x (0 dB) to 4x (12 dB), 0.001x step
AEC/AGC	Yes
Black level offset	Manual (0–4095), auto
Exposure control	Manual, auto, external, off
White balance	Once, manual, auto, off
Polarization angles	0, 45, 90, and 135 degrees
Area of interest (AOI)	Two
Trigger inputs	External, pulse generator, software
Trigger options	Edge, pulse width, trigger delay, debounce
Trigger modes	Free-run, standard, fast
I/O control	2 IN (OPTO, LVTTTL) / 2 OUT (OPTO, TTL)
Strobe output	2 strobes, programmable position and duration
Pulse generator	Yes, programmable
Lens mount	C-mount (default), P-Iris (optional)
Camera housing	6000 series aluminum
Upgradeable firmware	Yes
Data correction	4 LUTs: pre-programmed with Gamma 0.45 and negative LUT, flat field correction, bad pixel correction (static)
Supply voltage range	12 VDC (6 V–30 V), 1.5 A inrush @ 12 V; PoE (IEEE 802.3af/IEEE 802.3at)
Power	Typical: 3.27 W @ 12 V; PoE: 4.69 W
Camera size (W x H x L)	37 x 37 x 61.6 mm
Weight	125.2 grams
Vibration, shock	20G (20–200 Hz XYZ) / 100G
Environmental	Operating -30 °C to +75 °C (-40 °C to +85 °C tested) Storage -40 °C to +85 °C
Relative humidity	10% to 90% non-condensing
Regulatory	FCC part 15 Class A, CE, RoHS, UKCA
MTBF	530,000 hours @ 50 °C (EST) (Telcordia SR-332)

C3210 Camera Specifications

Specifications	POE-C3210, P67-C3210 (7.1 MP)	
Active image resolution	3216 (H) x 2208 (V)	
Pixel size	4.5 µm	
Optical format	1.1 inch	
Shutter	Global	
Frame rate (max)	16 fps (8-bit), 8 fps (10, 12-bit unpacked), 10 fps (10, 12-bit packed)	
Sensor digitization	12-bit	
Dynamic range	77 dB	
Output bit depth	8, 10, or 12-bit	
Shutter speed	32 µs to 16.0 s	
Analog / Digital gain	Manual, auto; 0–48 dB (0.1 dB step)	
Digital gain	1x (0 dB) to 4x (12 dB), 0.001x step	
AEC/AGC	Yes	
Black level offset	Manual (0–4095), auto	
Exposure control	Manual, auto, external, off	
White balance	Once, manual, auto, off	
Area of interest (AOI)	Two	
Binning	1x2, 2x1, 2x2 (available in monochrome cameras only)	
Sub-sampling	1x2, 2x1, 2x2	
Trigger inputs	External, pulse generator, software	
Trigger options	Edge, pulse width, trigger delay, debounce	
Trigger modes	Free-run, standard, fast	
I/O control	POE	2 IN (OPTO, LVTTTL) / 2 OUT (OPTO, TTL)
	P67	1 IN (OPTO) / 2 OUT (OPTO, TTL)
Strobe output	2 strobes, programmable position and duration	
Pulse generator	Yes, programmable	
Lens mount	POE	C-mount (default), P-Iris (optional)
	P67	C-mount (default)
Camera housing	6000 series aluminum	
Upgradeable firmware	Yes	
Data correction	4 LUTs: pre-programmed with Gamma 0.45 and negative LUT, flat field correction, bad pixel correction (static)	
Supply voltage range	12 VDC (6 V–30 V), 1.5 A inrush @ 12 V; PoE (IEEE 802.3af/IEEE 802.3at)	
Power consumption	Typical: 4.32 W @ 12 V; PoE: 5.95 W	
Camera size (W x H x L)	POE	37 x 37 x 61.6 mm
	P67	48.5 x 42 x 61 mm (without a lens tube)
Weight	POE	125.2 grams
	P67	196 grams (without a lens tube)
Vibration, shock	20G (20–200 Hz XYZ) / 100G	
Environmental	Operating	-30 °C to +75 °C (-40 °C to +85 °C tested)
	Storage	-40 °C to +85 °C
Relative humidity	10% to 90% non-condensing	
Regulatory	FCC part 15 Class A, CE, RoHS, UKCA	
MTBF	POE	530,000 hours @ 50 °C (EST) (Telcordia SR-332)
	P67	550,000 hours @ 50 °C (EST) (Telcordia SR-332)

C4010 Cameras Specifications

Specifications	POE-C4010, P67-C4010 (9 MP)	
Active image resolution	4112 (H) x 2176 (V)	
Pixel size	3.45 µm	
Optical format	1 inch	
Shutter	Global	
Frame rate (max)	13.2 fps (8-bit), 6.6 fps (10, 12-bit unpacked), 8.8 fps (10, 12-bit packed)	
Sensor digitization	12-bit	
Dynamic range	71 dB	
Output bit depth	8, 10, or 12-bit	
Shutter speed	49 µs to 16.0 s	
Analog / Digital gain	Manual, auto; 0–48 dB (0.1 dB step)	
Digital gain	1x (0 dB) to 4x (12 dB), 0.001x step	
AEC/AGC	Yes	
Black level offset	Manual (0–4095), auto	
Exposure control	Manual, auto, external, off	
White balance	Once, manual, auto, off	
Area of interest (AOI)	Two	
Sub-sampling	1x2, 2x1, 2x2	
Trigger inputs	External, pulse generator, software	
Trigger options	Edge, pulse width, trigger delay, debounce	
Trigger modes	Free-run, standard, fast	
I/O control	POE	2 IN (OPTO, LVTTTL) / 2 OUT (OPTO, TTL)
	P67	1 IN (OPTO) / 2 OUT (OPTO, TTL)
Strobe output	2 strobes, programmable position and duration	
Pulse generator	Yes, programmable	
Lens mount	POE	C-mount (default), P-Iris (optional)
	P67	C-mount (default)
Camera housing	6000 series aluminum	
Upgradeable firmware	Yes	
Data correction	4 LUTs: pre-programmed with Gamma 0.45 and negative LUT, flat field correction, bad pixel correction (static)	
Supply voltage range	12 VDC (6 V–30 V), 1.5 A inrush @ 12 V; PoE (IEEE 802.3af/IEEE 802.3at)	
Power consumption	Typical: 3.36 W @ 12 V; PoE: 4.91 W	
Camera size (W x H x L)	POE	37 x 37 x 61.6 mm
	P67	48.5 x 42 x 61 mm (without lens tube)
Weight	POE	125.2 grams
	P67	196 grams (without lens tube)
Vibration, shock	20G (20–200 Hz XYZ) / 100G	
Environmental	Operating	-30 °C to +75 °C (-40 °C to +85 °C tested)
	Storage	-40 °C to +85 °C
Relative humidity	10% to 90% non-condensing	
Regulatory	FCC part 15 Class A, CE, RoHS, UKCA	
MTBF	POE	530,000 hours @ 50 °C (EST) (Telcordia SR-332)
	P67	550,000 hours @ 50 °C (EST) (Telcordia SR-332)

C4110 Camera Specifications

Specifications	POE-C4110, P67-C4110 (12 MP)	
Active image resolution	4112 (H) x 3008 (V)	
Pixel size	3.45 µm	
Optical format	1.1 inch	
Shutter	Global	
Frame rate (max)	9.6 fps (8-bit), 4.8 fps (10, 12-bit unpacked), 6.4 fps (10, 12-bit packed)	
Sensor digitization	12-bit	
Dynamic range	71 dB	
Output bit depth	8, 10, or 12-bit	
Shutter speed	49 µs to 16.0 s	
Analog / Digital gain	Manual, auto; 0–48 dB (0.1 dB step)	
Digital gain	1x (0 dB) to 4x (12 dB), 0.001x step	
AEC/AGC	Yes	
Black level offset	Manual (0–4095), auto	
Exposure control	Manual, auto, external, off	
White balance	Once, manual, auto, off	
Area of interest (AOI)	Two	
Sub-sampling	1x2, 2x1, 2x2	
Trigger inputs	External, pulse generator, software	
Trigger options	Edge, pulse width, trigger delay, debounce	
Trigger modes	Free-run, standard, fast	
I/O control	POE	2 IN (OPTO, LVTTTL) / 2 OUT (OPTO, TTL)
	P67	1 IN (OPTO) / 2 OUT (OPTO, TTL)
Strobe output	2 strobes, programmable position and duration	
Pulse generator	Yes, programmable	
Lens mount	POE	C-mount (default), P-Iris (optional)
	P67	C-mount (default)
Camera housing	6000 series aluminum	
Upgradeable firmware	Yes	
Data correction	4 LUTs: pre-programmed with Gamma 0.45 and negative LUT, flat field correction, bad pixel correction (static)	
Supply voltage range	12 VDC (6 V–30 V), 1.5 A inrush @ 12 V; PoE (IEEE 802.3af/IEEE 802.3at)	
Power consumption	Typical: 3.48 W @ 12 V; PoE: 4.86 W	
Camera size (W x H x L)	POE	37 x 37 x 61.6 mm
	P67	48.5 x 42 x 61 mm (without lens tube)
Weight	POE	125.2 grams
	P67	196 grams (without lens tube)
Vibration, shock	20G (20–200 Hz XYZ) / 100G	
Environmental	Operating	-30 °C to +75 °C (-40 °C to +85 °C tested)
	Storage	-40 °C to +85 °C
Relative humidity	10% to 90% non-condensing	
Regulatory	FCC part 15 Class A, CE, RoHS, UKCA	
MTBF	POE	530,000 hours @ 50 °C (EST) (Telcordia SR-332)
	P67	550,000 hours @ 50 °C (EST) (Telcordia SR-332)

C4410 Cameras Specifications

Specifications	POE-C4410 (20 MP)
Active image resolution	4432 (H) x 4436 (V)
Pixel size	3.45 μm
Optical format	4/3 inch
Shutter	Global
Frame rate (max)	6 fps (8-bit), 3 fps (10, 12-bit unpacked), 4 fps (10, 12-bit packed)
Sensor digitization	12-bit
Dynamic range	71 dB
Output bit depth	8, 10, or 12-bit
Shutter speed	68 μs to 16.0 s
Analog / Digital gain	Manual, auto; 0–48 dB (0.1 dB step)
Digital gain	1x (0 dB) to 4x (12 dB), 0.001x step
AEC/AGC	Yes
Black level offset	Manual (0–4095), auto
Exposure control	Manual, auto, external, off
White balance	Once, manual, auto, off
Area of interest (AOI)	Two
Binning	1x2, 2x1, 2x2 (in mono cameras only)
Sub-sampling	1x2, 2x1, 2x2
Trigger inputs	External, pulse generator, software
Trigger options	Edge, pulse width, trigger delay, debounce
Trigger modes	Free-run, standard, fast
I/O control	2 IN (OPTO, LVTTTL) / 2 OUT (OPTO, TTL)
Strobe output	2 strobes, programmable position and duration
Pulse generator	Yes, programmable
Lens mount	F-mount (default), Canon EOS active or passive, M42 (optional)
Camera housing	6000 series aluminum
Upgradeable firmware	Yes
Data correction	4 LUTs: pre-programmed with Gamma 0.45 and negative LUT, flat field correction, bad pixel correction (static)
Supply voltage range	12 VDC (6 V–30 V), 1.5 A inrush @ 12 V; PoE (IEEE 802.3af/IEEE 802.3at)
Power consumption	Typical: 5.4 W @ 12 V; Max: 7.8 W; PoE: 6.5 W; PoE (Max): 7 W (Max – with enabled Canon controller)
Camera size (W x H x L)	60 x 60 x 56.5 mm
Weight	475.7 g
Vibration, shock	20G (20–200 Hz XYZ) / 100G
Environmental	Operating -30 °C to +75 °C (-40 °C to +85 °C tested) Storage -40 °C to +85 °C
Relative humidity	10% to 90% non-condensing
Regulatory	FCC part 15 Class A, CE, RoHS, UKCA
MTBF	452,000 hours @ 50 °C (EST) (Telcordia SR-332)

C5410 Cameras Specifications

Specifications	POE-C5410 (17 MP)
Active image resolution	5472 (H) x 3084 (V)
Pixel size	3.45 μm
Optical format	4/3 inch
Shutter	Global
Frame rate (max)	7 fps (8-bit), 3.5 fps (10, 12-bit unpacked), 4.6 fps (10, 12-bit packed)
Sensor digitization	12-bit
Dynamic range	71 dB
Output bit depth	8, 10, or 12-bit
Shutter speed	76 μs to 16.0 s
Analog / Digital gain	Manual, auto; 0–48 dB (0.1 dB step)
Digital gain	1x (0 dB) to 4x (12 dB), 0.001x step
AEC/AGC	Yes
Black level offset	Manual (0–4095), auto
Exposure control	Manual, auto, external, off
White balance	Once, manual, auto, off
Area of interest (AOI)	Two
Binning	1x2, 2x1, 2x2 (in mono cameras only)
Sub-sampling	1x2, 2x1, 2x2
Trigger inputs	External, pulse generator, software
Trigger options	Edge, pulse width, trigger delay, debounce
Trigger modes	Free-run, standard, fast
I/O control	2 IN (OPTO, LVTTTL) / 2 OUT (OPTO, TTL)
Strobe output	2 strobes, programmable position and duration
Pulse generator	Yes, programmable
Lens mount	F-mount (default), Canon EOS active or passive, M42 (optional)
Camera housing	6000 series aluminum
Upgradeable firmware	Yes
Data correction	4 LUTs: pre-programmed with Gamma 0.45 and negative LUT, flat field correction, bad pixel correction (static)
Supply voltage range	12 VDC (6 V–30 V), 1.5 A inrush @ 12 V; PoE (IEEE 802.3af/IEEE 802.3at)
Power consumption	Typical: 5.4 W @ 12 V; Max: 7.8 W PoE: 6.5 W; PoE (Max): 7 W (Max – with enabled Canon controller)
Camera size (W x H x L)	60 x 60 x 56.5 mm
Weight	475.7 g
Vibration, shock	20G (20–200 Hz XYZ) / 100G
Environmental	Operating -30 °C to +75 °C (-40 °C to +85 °C tested) Storage -40 °C to +85 °C
Relative humidity	10% to 90% non-condensing
Regulatory	FCC part 15 Class A, CE, RoHS, UKCA
MTBF	452,000 hours @ 50 °C (EST) (Telcordia SR-332)

C6410 Camera Specifications

Specifications	POE-C6410 (31 MP)
Active image resolution	6480 (H) x 4860 (V)
Pixel size	3.45 μm
Optical format	APS-C
Shutter	Global
Frame rate (max)	3.7 fps (8-bit), 1.8 fps (10, 12-bit unpacked), 2.5 fps (10, 12-bit packed)
Sensor digitization	12-bit
Dynamic range	71 dB
Output bit depth	8, 10, or 12-bit
Shutter speed	85 μs to 16.0 s
Analog / Digital gain	Manual, auto; 0–48 dB (0.1 dB step)
Digital gain	1x (0 dB) to 4x (12 dB), 0.001x step
AEC/AGC	Yes
Black level offset	Manual (0–4095), auto
Exposure control	Manual, auto, external, off
White balance	Once, manual, auto, off
Area of interest (AOI)	Two
Binning	1x2, 2x1, 2x2 (available in monochrome cameras only)
Sub-sampling	1x2, 2x1, 2x2
Trigger inputs	External, pulse generator, software
Trigger options	Edge, pulse width, trigger delay, debounce
Trigger modes	Free-run, standard, fast
I/O control	2 IN (OPTO, LVTTTL) / 2 OUT (OPTO, TTL)
Strobe output	2 strobes, programmable position and duration
Pulse generator	Yes, programmable
Lens mount	F-mount (default), Active or passive Canon EOS, M42 (optional)
Camera housing	6000 series aluminum
Upgradeable firmware	Yes
Data correction	4 LUTs: pre-programmed with Gamma 0.45 and negative LUT, flat field correction, bad pixel correction (static)
Supply voltage range	12 VDC (6 V–30 V), 1.5 A inrush @ 12 V; PoE (IEEE 802.3af/IEEE 802.3at)
Power consumption	Typical: 5.4 W @ 12 V; Max: 7.8 W (w/enabled Canon controller) PoE: 6.5 W; PoE (Max): 7 W (w/enabled Canon controller)
Camera size (W x H x L)	60 x 60 x 56.5 mm
Weight	475.7 g
Vibration, shock	20G (20–200 Hz XYZ) / 100G
Environmental	Operating -30 °C to +75 °C (-40 °C to +85 °C tested) Storage -40 °C to +85 °C
Relative humidity	10% to 90% non-condensing
Regulatory	FCC part 15 Class A, CE, RoHS, UKCA
MTBF	452,000 hours @ 50 °C (EST) (Telcordia SR-332)

C4410-T Camera Specifications

Specifications	POE-C4410-T (20 MP)
Active image resolution	4432 (H) x 4436 (V)
Pixel size	3.45 μm
Optical format	4/3 inch
Shutter	Global
Frame rate (max)	6 fps (8-bit), 3 fps (10, 12-bit unpacked), 4 fps (10, 12-bit packed)
Sensor digitization	12-bit
Dynamic range	71 dB
Output bit depth	8, 10, or 12-bit
Shutter speed	68 μs to 16.0 s
Analog / Digital gain	Manual, auto; 0–48 dB (0.1 dB step)
Digital gain	1x (0 dB) to 4x (12 dB), 0.001x step
AEC/AGC	Yes
Black level offset	Manual (0–4095), auto
Exposure control	Manual, auto, external, off
White balance	Once, manual, auto, off
Area of interest (AOI)	Two
Binning	1x2, 2x1, 2x2 (available in monochrome cameras only)
Sub-sampling	1x2, 2x1, 2x2
Trigger inputs	External, pulse generator, software
Trigger options	Edge, pulse width, trigger delay, debounce
Trigger modes	Free-run, standard, fast
I/O control	2 IN (OPTO, LVTTTL) / 2 OUT (OPTO, TTL)
Strobe output	2 strobes, programmable position and duration
Pulse generator	Yes, programmable
TEC	Up to 20 °C below camera heat-sink temperature
TEC control	On, off, auto
Forced air cooling control	Auto
Lens mount	F-mount (default), Canon EOS active or passive, M42 (optional)
Camera housing	6000 series aluminum
Upgradeable firmware	Yes
Data correction	4 LUTs: pre-programmed with Gamma 0.45 and negative LUT, flat field correction, bad pixel correction (static)
Supply voltage range	12 VDC (6 V–30 V), 1.5 A inrush @ 12 V; PoE (IEEE 802.3af/IEEE 802.3at)
Power consumption	Typ. (TEC off): 5.4 W @ 12 V; PoE: 6.5 W Max. (TEC on): 11.4 W @ 12 V; PoE: 12.5 W
Camera size (W x H x L)	60 x 64.4 x 70 mm
Weight	453 g
Vibration, shock	20G (20–200 Hz XYZ) / 100G
Environmental	Operating -30 °C to +70 °C Storage -40 °C to +85 °C
Relative humidity	10% to 90% non-condensing
Regulatory	FCC part 15 Class A, CE, RoHS, UKCA
MTBF	378,000 hours @ 50 °C (EST) (Telcordia SR-332)

C5410-T Camera Specifications

Specifications	POE-C5410-T (17 MP)
Active image resolution	5472 (H) x 3084 (V)
Pixel size	3.45 μm
Optical format	4/3 inch
Shutter	Global
Frame rate (max)	7 fps (8-bit), 3.5 fps (10, 12-bit unpacked), 4.6 fps (10, 12-bit packed)
Sensor digitization	12-bit
Dynamic range	71 dB
Output bit depth	8, 10, or 12-bit
Shutter speed	76 μs to 16.0 s
Analog / Digital gain	Manual, auto; 0–48 dB (0.1 dB step)
Digital gain	1x (0 dB) to 4x (12 dB), 0.001x step
AEC/AGC	Yes
Black level offset	Manual (0–4095), auto
Exposure control	Manual, auto, external, off
White balance	Once, manual, auto, off
Area of interest (AOI)	Two
Binning	1x2, 2x1, 2x2 (available in monochrome cameras only)
Sub-sampling	1x2, 2x1, 2x2
Trigger inputs	External, pulse generator, software
Trigger options	Edge, pulse width, trigger delay, debounce
Trigger modes	Free-run, standard, fast
I/O control	2 IN (OPTO, LVTTTL) / 2 OUT (OPTO, TTL)
Strobe output	2 strobes, programmable position and duration
Pulse generator	Yes, programmable
TEC	Up to 20 °C below camera heat-sink temperature
TEC control	On, off, auto
Forced air cooling control	Auto
Lens mount	F-mount (default), Canon EOS active or passive, M42 (optional)
Camera housing	6000 series aluminum
Upgradeable firmware	Yes
Data correction	4 LUTs: pre-programmed with Gamma 0.45 and negative LUT, flat field correction, bad pixel correction (static)
Supply voltage range	12 VDC (6 V–30 V), 1.5 A inrush @ 12 V; PoE (IEEE 802.3af/IEEE 802.3at)
Power consumption	Typ. (TEC off): 5.4 W @ 12 V (EST); PoE: 6.5 W Max. (TEC on): 11.4 W @ 12 V (EST); PoE: 12.5 W
Camera size (W x H x L)	60 x 64.4 x 70 mm
Weight	453 g
Vibration, shock	20G (20–200 Hz XYZ) / 100G
Environmental	Operating Storage
	-30 °C to +70 °C -40 °C to +85 °C
Relative humidity	10% to 90% non-condensing
Regulatory	FCC part 15 Class A, CE, RoHS, UKCA
MTBF	378,000 hours @ 50 °C (EST) (Telcordia SR-332)

C6410-T Camera Specifications

Specifications	POE-C6410 (31 MP)
Active image resolution	6480 (H) x 4860 (V)
Pixel size	3.45 μm
Optical format	APS-C
Shutter	Global
Frame rate (max)	3.7 fps (8-bit), 1.8 fps (10, 12-bit unpacked), 2.5 fps (10, 12-bit packed)
Sensor digitization	12-bit
Dynamic range	71 dB
Output bit depth	8, 10, or 12-bit
Shutter speed	85 μs to 16.0 s
Analog / Digital gain	Manual, auto; 0–48 dB (0.1 dB step)
Digital gain	1x (0 dB) to 4x (12 dB), 0.001x step
AEC/AGC	Yes
Black level offset	Manual (0–4095), auto
Exposure control	Manual, auto, external, off
White balance	Once, manual, auto, off
Area of interest (AOI)	Two
Binning	1x2, 2x1, 2x2 (available in monochrome cameras only)
Sub-sampling	1x2, 2x1, 2x2
Trigger inputs	External, pulse generator, software
Trigger options	Edge, pulse width, trigger delay, debounce
Trigger modes	Free-run, standard, fast
I/O control	2 IN (OPTO, LVTTTL) / 2 OUT (OPTO, TTL)
Strobe output	2 strobes, programmable position and duration
Pulse generator	Yes, programmable
TEC	Up to 20 °C below camera heat-sink temperature
TEC control	On, off, auto
Forced air cooling control	Auto
Lens mount	F-mount (default), Active or passive Canon EOS, M42 (optional)
Camera housing	6000 series aluminum
Upgradeable firmware	Yes
Data correction	4 LUTs: pre-programmed with Gamma 0.45 and negative LUT, flat field correction, bad pixel correction (static)
Supply voltage range	12 VDC (6 V–30 V), 1.5 A inrush @ 12 V; PoE (IEEE 802.3af/IEEE 802.3at)
Power consumption	Typ. (TEC off): 5.4 W @ 12 V; PoE: 6.5 W Max. (TEC on): 11.4 W @ 12 V; PoE: 12.5 W
Camera size (W x H x L)	60 x 64.4 x 70 mm
Weight	453 g
Vibration, shock	20G (20–200 Hz XYZ) / 100G
Environmental	Operating -30 °C to +70 °C Storage -40 °C to +85 °C
Relative humidity	10% to 90% non-condensing
Regulatory	FCC part 15 Class A, CE, RoHS, UKCA
MTBF	378,000 hours @ 50 °C (EST) (Telcordia SR-332)

Ordering Information

When ordering a camera, please specify the camera ordering code. To create your own customer Cheetah ordering code, simply choose one element from each column in table below.

For P67 camera, please select a lens tube that matches the size of your lens.

Interface	Camera model	Sensor Type	Environmental	Lens Mount (see Note 1 below)	Filter/cus tomizatio n options
POE = GigE Vision® with Power over Ethernet	C1911 (1944 x 1472)	C = Color	R= Ruggedized	C = C-Mount	000 =
	C2000 (2064 x 1544)	M = Monochrome	T= Thermoelectric cooling	S = CS-Mount	none
	C2400 (2464 x 2056)	Y = Color	(T is only available for:	I = P-Iris C	(see
	C2010 (2064 x 1544)	Polarized	POE-C4410,	A = P-Iris CS	Note 4
	C2410 (2464 x 2056)	Z = Monochrome	POE-C5410,	F= F-Mount	below)
	C3210 (3216 x 2208)	Polarized	POE-C6410)	M = M42	
	C4010 (4112 x 2176)	(Y and Z types are only available for		L= Canon EF	
	C4110 (4112 x 3008)	POE-C2410)		EOS Active	
	C4410 (4432 x 4436)			Mount	
C5410 (5472 x 3084)			E = Canon EF		
C6410 (6480 x 4860)			EOS Passive		
			Mount		
P67 = GigE Vision® with Power over Ethernet (in IP67-rated enclosure)	C1911 (1944 x 1472)	C = Color	R= Ruggedized	C = C-Mount	000 =
	C2010 (2064 x 1544)	M = Monochrome			none
	C2410 (2464 x 2056)				(see
	C3210 (3216 x 2208)				Note 4
	C4010 (4112 x 2176)				below)
C4110 (4112 x 3008)					

Notes:

- 1) **C-Mount** is supported by the POE-C1911, POE-C2000, POE-C2400, POE-C2010, POE-C2410, POE-C2410Y/Z, POE-C3210, POE-C4010, POE-C4110, P67-C1911, P67-C2010, P67-C2410, P67-C3210, P67-C4010, and P67-C4110 cameras.
CS-Mount is supported by the POE-C1911, POE-C2010, POE-C2410, POE-C3210, POE-C4010, POE-C4110 cameras.
F-Mount, M42, Canon EOS EF active or passive are supported by the POE-C4410, POE-C5410, POE-C6410, POE-C4410-T, POE-C5410-T, and POE-C6410-T cameras.
P-Iris C-Mount and P-Iris CS-Mount are supported by the POE-C1911, POE-C2010, POE-C2410, POE-C3210, POE-C4010, and POE-C4110 cameras.
- 2) A POE Power Supply injector/ LAN Power or external power supply is required.
- 3) The Imperx PS12V04A power supply is available for use with POE camera models (except, C2000 and C2400) and can be purchased separately. To power the P67 cameras use an appropriate external power supply and IP67-rated cables.
- 4) **000 (none)** filter/customization option means that a color camera has IR-cut filter, while a monochrome camera does not have any filters.
- 5) Sample codes:
POE-C2400C-RC000: Cheetah Color 5 MP camera with C mount and GigE Vision® w/PoE interface;
POE-C3210M-RI000: Cheetah Monochrome 7.1 MP camera with P-Iris C-Mount and GigE Vision® w/PoE interface;
P67-C4010M-RC000: Cheetah Monochrome 9 MP camera with C-Mount and GigE Vision® w/PoE interface in IP67-rated enclosure;
POE-C4110Y-RC000: Cheetah Color Polarized 12 MP camera with C-Mount and GigE Vision® w/PoE interface;
POE-C5410C-RL000: Cheetah Color 17 MP camera with Canon EF EOS active mount and GigE Vision® w/PoE interface;
POE-C6410C-TF000: Cheetah Color 31 MP camera with thermoelectric cooling, F-mount, and GigE Vision® w/PoE interface.

Accessories

Imperx offers a wide variety of accessories—power supplies, cables, lens tubes—for use with the cameras. The accessories are listed in the tables below and sold separately.

Power Supply

Part Number	Description	Compatible with
PS12V14A	Universal Power Supply 12 V DC, 3 A, With one strobe and one trigger, 1.75 m length	POE-C1911, POE-C2010, POE-C2410, POE-C2410Y/Z, POE-C3210, POE-C4010, POE- C4110, POE-C4410, POE-C5410, POE-C6410, POE-C4410-T, POE-C5410-T, POE-C6410-T
PS12V18A	Universal Power Supply 12 V DC, 3 A, With one strobe, one trigger, and P-Iris connector 1.75 m length	POE-C1911, POE-C2010, POE-C2410, POE-C2410Y/Z, POE-C3210, POE-C4010, POE- C4110 (with P-Iris control)

Cables

Part Number	Description	Length	Compatible with
CBL-COM01	Input/Output, 6-pin (F) Hirose to loose end	2 m	POE-C2000, POE-C2400
CBL-PWIO01	Power and Input/Output, 12-pin (F) Hirose to loose end,	2 m	POE-C1911, POE-C2010, POE-C2410, POE-C2410Y/Z, POE-C3210, POE-C4010, POE-C4110, POE-C4410, POE-C5410, POE-C6410 POE-C4410-T POE-C5410-T POE-C6410-T
CBL-IO08-0001	Input/Output, 8-pin (F) BULGIN CONN to Pigtail	2 m	P67-C1911,
CBL-XRJ45-0002	RJ45 to 8 position M12/Xcode (IP67 METZ CONN)	2 m	P67-C2010,
CBL-XRJ45-0003	RJ45 to 8 position M12/Xcode (IP67 METZ CONN)	3 m	P67-C2410,
CBL-XRJ45-0005	RJ45 to 8 position M12/Xcode (IP67 METZ CONN)	5 m	P67-C3210, P67-C4010, P67-C4110
CBL-XRJ45-0010	RJ45 to 8 position M12/Xcode (IP67 METZ CONN)	10 m	
CBL-XRJ45-0015	RJ45 to 8 position M12/Xcode (IP67 METZ CONN)	15 m	
CBL-XRJ45-0020	RJ45 to 8 position M12/Xcode (IP67 METZ CONN)	20 m	

IP67 Lens Tubes and Extension Kit

Part Number	Inner length*	Inner diameter	Outer diameter	Protective Glass	Material
Tube-44MM-0036 (default)	36 mm				
Tube-44MM-0042	42 mm				
Tube-44MM-0048	48 mm				
Tube-44MM-0054	54 mm	Ø 44 mm	Ø 50 mm	Clear Glass Ø 49 mm x 2 mm with oleophobic coating	Aluminum
Tube-44MM-0060	60 mm				
Tube-44MM-0066	66 mm				
Tube-44MM-0072	72 mm				
Tube-44MM-0078	78 mm				
Tube-64MM-0080 (default)	80 mm	Ø 64 mm	Ø 70 mm	Clear Glass Ø 69 mm x 2 mm with oleophobic coating	

*Custom Tube Lengths are available, please contact your local distributor or Imperx sales at:
 Email: sales@imperx.com Phone (+1) 561-989-0006

Technical Support

Each camera is fully tested before shipping. If, for some reason, the camera is not operational after power up, check the following:

1. Check the power supply and all I/O cables.
Make sure that all the connectors are firmly attached.
2. Check the status LED and verify that it is steady ON, if not—refer to the section [Camera LED Status Indicator](#).
3. Enable the test mode and verify that the communication between a computer and the camera is established.
If the test pattern is not present, power off the camera, check all the cabling, frame grabber settings, and computer status.

If you still have problems with the camera operation, contact technical support at:

Email: support@imperx.com

Toll Free 1 (866) 849-1662 or (+1) 561-989-0006

Fax: (+1) 561-989-0045

Visit our website: www.imperx.com

Hardware

This chapter contains the detailed information needed for the initial design-in process:

- connector types, pin numbering and assignments
- power supply and cabling
- electrical connectivity and voltage requirements
- mechanical drawings
- optical and environmental information

C2000 and C2400 Cameras Connectivity

The back panel of the POE-C2000 and POE-C2400 camera provides all the connectors needed to operate and control the camera. The RJ-45 connector provides link status LED indicators.



The camera provides the following connectors:

- a standard RJ-45 connector provides data, sync, control, and serial interface with LED indicator to indicate link status.
Power can be provided to the camera using a POE power injector or LAN Power.
- a male 6-pin Hirose miniature locking receptacle #HR10A-7R-6PB(73) providing alternative power input and I/O interface

C2000 and C2400 Pin Assignment

The RJ-45 connector's pin assignment conforms to the Ethernet standard IEEE 802.3 1000BASE-T.

The 6-pin Hirose connector on the camera's back panel is a male type miniature locking receptacle #HR10A-7R-6PB(73) mating to a female Hirose type miniature locking plug #HR10A-7P-6S(73).

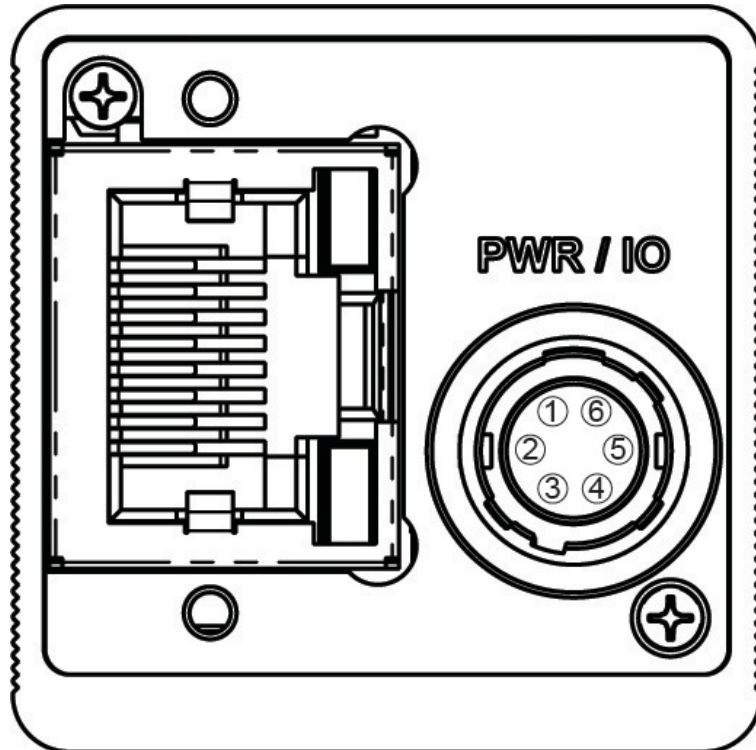

Pin	Signal Name	Use
1	+12 V DC	12 VDC Main Power
2	INPUT1	General Purpose Input 1 (Opto-isolated)
3	INPUT1 RTN	General Purpose Input 1, Return (Opto-isolated)
4	OUT1	General Purpose Output 1, Contact 1 (Opto-isolated)
5	OUT1 RTN	General Purpose Output 2, Contact 2 (Opto-isolated)
6	+12 V DC RTN	12 VDC Main Power Return

POE-C1911, POE-C2010, POE-C2410, POE-C3210, POE-C4010 and POE-C4110 Cameras Connectivity

The back panel of the camera provides all the connectors needed to operate and control the camera and an LED status indicator. The RJ-45 connector also features Ethernet link status LED indicators.

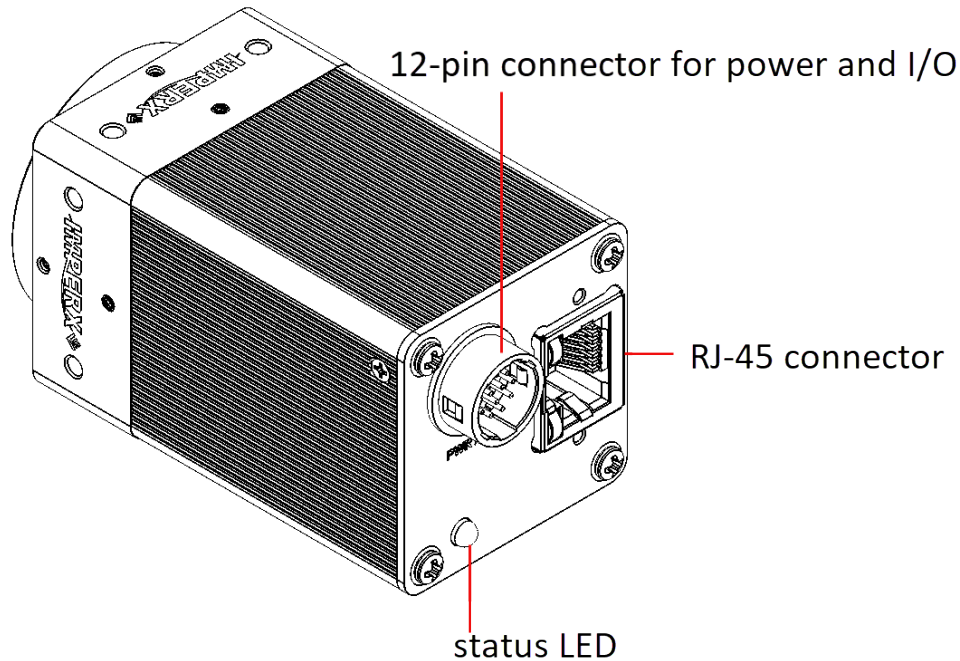

The camera provides the following connectors:

- a standard RJ-45 connector providing data, control, and serial interface. Power can be provided to the camera using a POE power injector or LAN power.
- a male 12-pin Hirose miniature locking receptacle #HR10A-10R-12PB (71) providing alternative power input and I/O interface. The mating connector is a female HIROSE plug #HR10A-10P-12S(73).
- a camera status LED indicator
- a camera's model and serial number

POE-C1911, POE-C2010, POE-C2410, POE-C3210, POE-C4010 and POE-C4110 Pin Assignments

The RJ-45 connector's pin assignment conforms to the Ethernet standard IEEE 802.3 1000BASE-T.

The 12-pin Hirose connector on the camera's back panel is a male type miniature locking receptacle #HR10A-10R-12PB(71). The Imperx PS12V14A power supply (sold separately, see [PS12V14A Universal Power Supply](#) section) terminates in a female Hirose type miniature locking plug #HR10A-10P-12S(73) and has two small BNC pig-tail cables for the external trigger input (black) and strobe output (white).

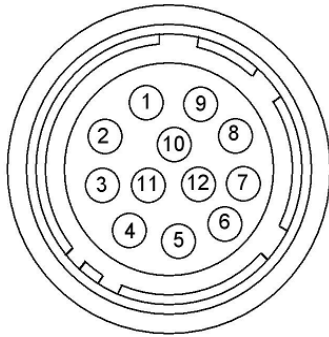

Pin	Signal Name	Use
1	+12 V DC RTN	12 VDC Main Power Return
2	+12 V DC	12 VDC Main Power
3	Reserved	Reserved
4	Reserved	Reserved
5	OUT2 RTN	General Purpose Output 2, Contact 1 (Opto-isolated)
6	OUT1 RTN	General Purpose Output 1 Return (TTL)
7	OUT1	General Purpose Output 1 (TTL)
8	INPUT1	General Purpose Input 1 (Opto-isolated)
9	INPUT2	General Purpose Input 2 (TTL/LVTTL)
10	INPUT1 RTN	General Purpose Input 1 Return (Opto-isolated)
11	INPUT2 RTN	General Purpose Input 2 Return (TTL/LVTTL)
12	OUT2	General Purpose Output 2, Contact 2 (Opto-isolated)

Connecting a P-IRIS Lens

POE-C1911, POE-C2010, POE-C2410, POE-C3210, POE-C4010 and POE-C4110 cameras are available with optional P-Iris lens mount. Signals from the camera’s Hirose connector provide power and control the P-Iris through an external cable.

Imperx recommends using the [PS12V18A](#) power supply that has a lens control cable terminated with a female P-Iris plug. The cable drawing is shown on the page [44](#).

If your application requires assembling you own cable, please refer to the diagram below that shows the P-Iris connections to the Hirose connector:

Hirose HR10A-10P-12S(73)
female plug

Signal	Pin
P-Iris Phase A+	5
P-Iris Phase B-	9
P-Iris Phase B+	11
P-Iris Phase A-	12

P-Iris jack

Pin	Signal
2	Phase A+
4	Phase B-
1	Phase B+
3	Phase A-

Hirose #HR10A-10P-12S(73)

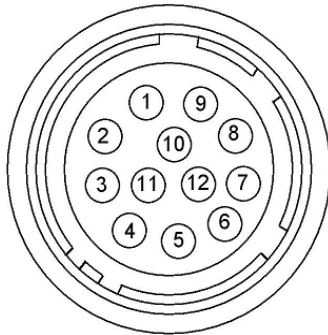

P-Iris jack (female):

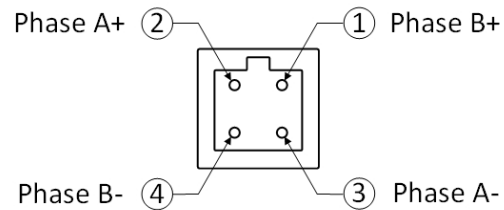

Pin	Signal Name	Use
1	+12 V DC RTN	12 VDC Main Power Return
2	+12 V DC	12 VDC Main Power
3	Reserved	Reserved
4	Reserved	Reserved
5	P-Iris Phase A+	Mapped to the pin 2 of a P-Iris jack
6	OUT1 RTN	General Purpose Output 1 Return (TTL)
7	OUT1	General Purpose Output 1 (TTL)
8	IN1	General Purpose Input 1 (Opto-isolated)
9	P-Iris Phase B-	Mapped to the pin 4 of a P-Iris jack

Pin	Signal Name	Use
10	IN1 RTN	General Purpose Input 1 Return (Opto-isolated)
11	P-Iris Phase B+	Mapped to the pin 1 of a P-Iris jack
12	P-Iris Phase A-	Mapped to the pin 3 of a P-Iris jack

C4410, C5410, C6410 Cameras Connectivity

The back panel of the camera provides all the connectors needed to operate and control the camera and an LED status indicator. The RJ-45 connector also features Ethernet link status LED indicators.

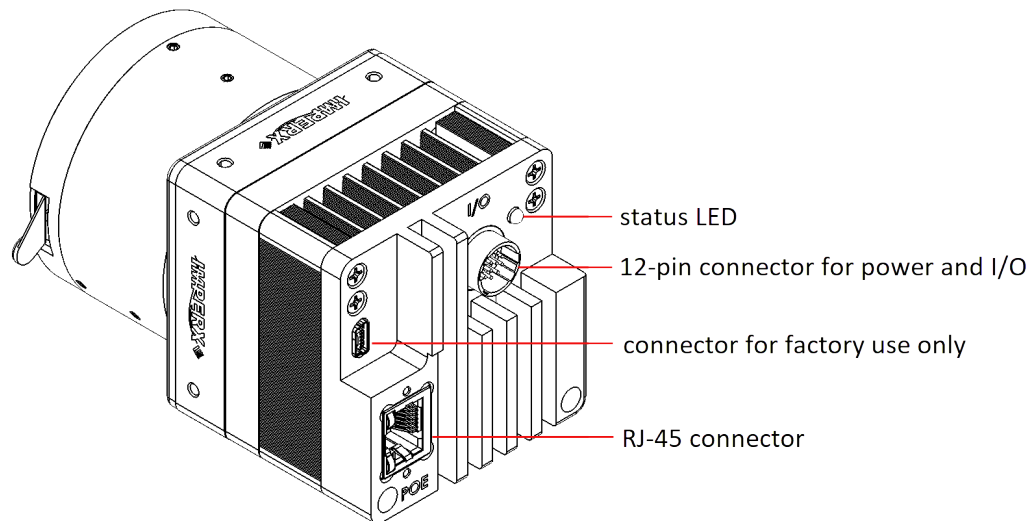

The camera provides the following connectors:

- a standard RJ-45 connector providing data, control, and serial interface. Power can be provided to the camera using a POE power injector or LAN power.
- male 12-pin Hirose miniature locking receptacle #HR10A-10R-12PB(71) providing alternative power input and I/O interface.
- a camera status LED indicator.
- USB type B programming/SPI connector.
- a camera's model and serial number

C4410, C5410, C6410 Pin Assignments

The RJ-45 connector's pin assignment conforms to the Ethernet standard IEEE 802.3 1000BASE-T.

The POE-C4410, POE-C5410, and POE-C6410 cameras have 12-pin Hirose connector. For pin-out and pin mapping please refer to the section [POE-C1911](#), [POE-C2010](#), [POE-C2410](#), [POE-C3210](#), [POE-C4010](#) and [POE-C4110 Pin Assignments](#).

C4410-T, C5410-T, C6410-T Cameras Connectivity

The back panel of the camera provides all the connectors needed to operate and control the camera and an LED status indicator. The RJ-45 connector also features Ethernet link status LED indicators.

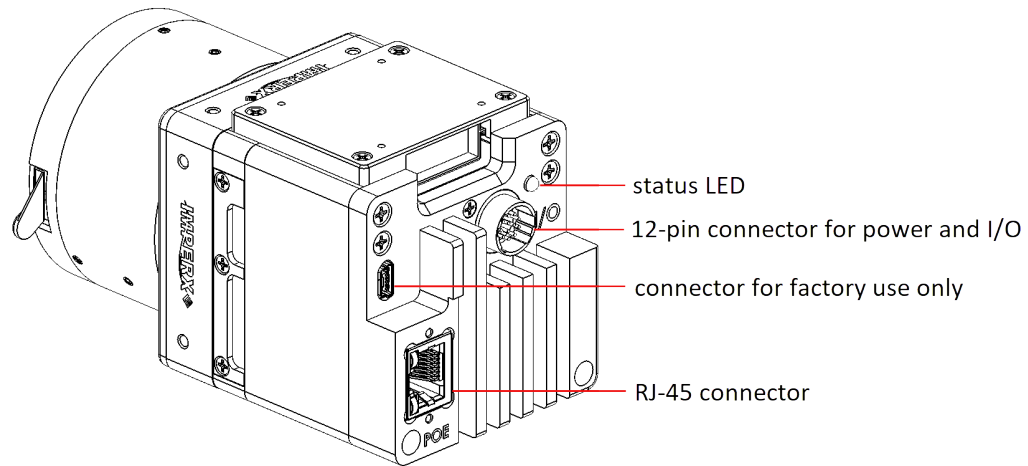

The camera provides the following connectors:

- a standard RJ-45 connector providing data, control, and serial interface. Power can be provided to the camera using a POE power injector or LAN power.
- male 12-pin Hirose miniature locking receptacle #HR10A-10R-12PB(71) providing alternative power input and I/O interface.
- a camera status LED indicator.
- USB type B programming/SPI connector.
- the camera's model and serial number

C4410-T, C5410-T, C6410-T Pin Assignments

The RJ-45 connector's pin assignment conforms to the Ethernet standard IEEE 802.3 100BASE-T.

The POE-C4410-T, POE-C5410-T, and POE-C6410-T cameras have 12-pin Hirose connector. For pin-out and pin mapping please refer to the section [POE-C1911](#), [POE-C2010](#), [POE-C2410](#), [POE-C3210](#), [POE-C4010](#) and [POE-C4110 Pin Assignments](#).

P67 Cameras Connectivity

The back panel of the camera provides all the connectors needed to operate and control the camera. The back panel also provides two LED status indicators.

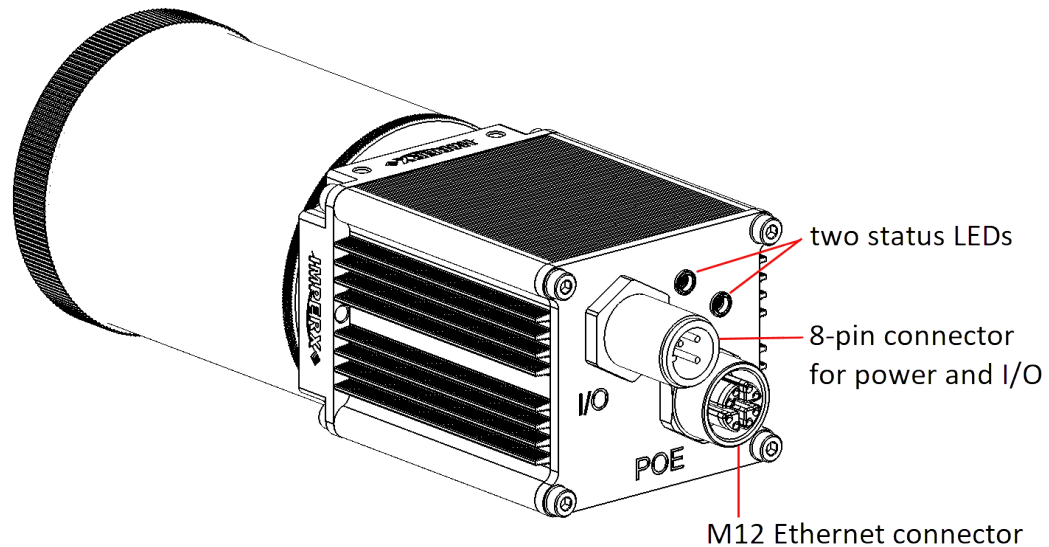

The camera provides the following connectors:

- Female MACOM MMT361A315 receptacle for the Ethernet interface. IP67 rating is only achieved when mated with IP67 rated cable; such as, Imperx P/N: CBL-XRJ45-00XX. Power can be provided to the camera using a POE power injector or LAN power. The mating connector is an IP67-rated M12 X-coded 8-position male plug.
- 8-pin male BULGIN PXMBNI12RPM08APCM12 connector providing alternative power input and I/O interface. IP67 rating is only achieved when mated to IP67 rated I/O cable; such as, Imperx P/N; CBL-IO08-0001. The mating part is an IP67 female plug BULGIN PXPTPU12FBF08ACL020PUR.
- two status LED indicators

CAUTION

Water can leak through the pins of the camera's unmated I/O and POE connectors. DO NOT SUBMERGE the camera or subject the camera to any type of water spray without first connecting IP67 cables to I/O and POE connectors. If the I/O connector is unused, cap the end of the connector with the IP67 rated cap supplied with the camera.

IP67 Power and I/O Connector Pin Assignments

The IP67-rated 8-pin male BULGIN PXMBNI12RPM08APCM12 connector provides alternative power input and all external input/output signals supplied to the camera.

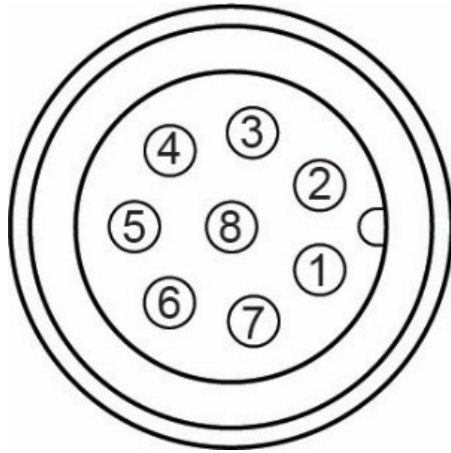

Pin	Signal Name	Use
1	Reserved	Reserved
2	+12 V DC	12 VDC Main Power
3	IN1	General Purpose Input 1 (Opto-isolated)
4	IN1/OUT1 RTN	General Purpose Input1 Return and Output 1, Contact 1 (Opto-isolated)
5	OUT2 RTN	General Purpose Output 2 Return (TTL)
6	OUT1	General Purpose Output 1, Contact 2 (Opto-isolated)
7	+12 V DC RTN	+12 VDC Main Power Return
8	OUT2	General Purpose Output 2 (TTL)

IP67 Ethernet Connector Pin Assignments











An IP67-rated MACOM MMT361A315 connector provides 1000BASE-T Ethernet interface. The pin assignment conforms to the Ethernet standard.



Pin	Signal Name	Cable wires
1	TD0+	White/Orange
2	TD0-	Orange
3	TD1+	White/Green
4	TD1-	Green
5	TD3+	White/Brown
6	TD3-	Brown
7	TD2-	White/Blue
8	TD2+	Blue

Camera LED Status Indicator

The camera has a red-green-yellow LED on the back panel of the camera. The following LED colors and light patterns indicate the camera status and mode of operation.

LED Condition	Status Indication
 Green steady ON	Normal operation. You should see a normal image coming out of the camera.
 Green blinks at ~0.5 Hz	Trigger enabled.
 Green blinks at ~2.0 Hz	Long integration enabled.
 Amber steady ON	Test mode. You should see one of the test patterns.
 Amber blinks at ~0.5 Hz	Camera is in AGC/AEC mode. In this mode, changing the shutter slider does not affect image luminance.
 Amber blinks at ~2.0 Hz	Camera receives an external synchronization pulse
 Red steady ON	Communications or firmware load error.*
 Red blinks at ~2.0 Hz	Power failure
 Green – Red blinks at ~1 Hz	GigE Vision firmware error.
 LED OFF	Power not present. Possible power supply failure or faulty external AC adapter. Re-power camera and load factory settings. If the LED is still OFF, contact the factory.

Powering the Camera

The camera can be powered using Local Area Network power, an external POE injector or an external Power Supply providing 6 V to 30 V DC with an inrush current capability of 2 A @ 12 V DC. If both a POE injector and external Power Supply are connected to the camera simultaneously, the camera will draw power from the external Power Supply, as long as the input voltage exceeds 12.6 V. If the external voltage drops below 12.6 V, the camera will draw power from the Power Injector.

Imperx offers the PS12V14A Power Supply for use with the following cameras: POE-C1911, POE-C2010, POE-C2410, POE-C3210, POE-C4010, POE-C4110, POE-C4410, POE-C5410, POE-C6410, POE-C4410-T, POE-C5410-T, and POE-C6410-T (see the [PS12V14A Power Supply](#) section).

Also, Imperx offers the PS12V18A Power Supply for use with Cheetah GigE Vision cameras having P-Iris lens (see the [PS12V18A Power Supply](#) section).

The PS12V14A and P12V18A Power Supplies can be purchased separately.

Imperx does not offer an external Power Supply for use with the C2000 and C2400 cameras, but does offer a cable assembly (P/N: CBL-COM01, Input/Output, 6-pin Hirose to unterminated cable, 2 meters long) so you can connect the camera to an external Power Supply and make connections to the trigger Input or Strobe Output.

Imperx offers IP67-rated cable assemblies for use with the P67-C1911, P67-C2010, P67-C2410, P67-C3210, P67-C4010, and P67-C4110 cameras (see [IP-67 rated Power and I/O Cable CBL-IO08-0001](#), [IP-67 Rated Gigabit Ethernet Cables CBL-XRJ45-00XX](#), and [Accessories](#)).

PS12V14A Power Supply

The PS12V14A power supply provides +12 V DC \pm 5% and up to 3 A DC current. The operating input voltage range is from 100 to 240 V AC.

The PS12V14A power supply is comprised of three components:

Item	Qty.
PS12V10 universal power supply	1
CBL-PWR-0014 power cable	1
power cord	1

The CBL-PWR-0014 cable terminates in a female Hirose type miniature locking plug #HR10A-10P-12S(73). It has two BNC pig-tail cables providing external trigger input (black) and strobe output (white).

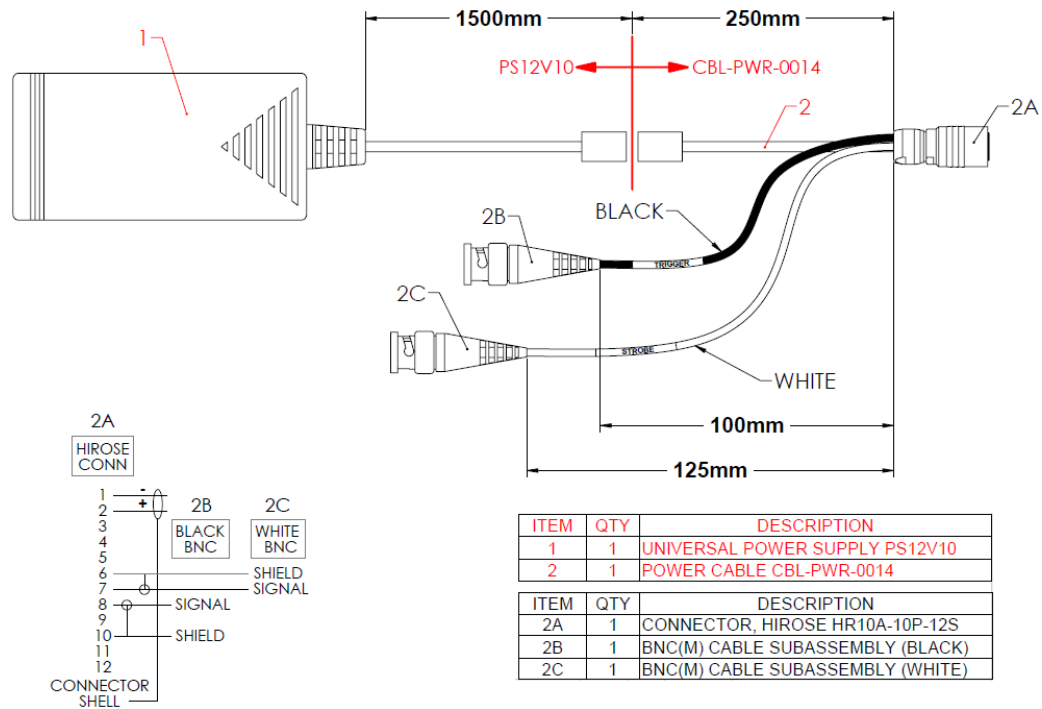

Imperx recommends using the PS12V14A power adapter for powering POE-C1911, POE-C2010, POE-C2410, POE-C3210, POE-C4010, POE-C4110, POE-C4410, POE-C5410, POE-C6410, POE-C4410-T, POE-C5410-T, and POE-C6410-T cameras.

PS12V18A Power Supply

The PS12V18A power supply provides +12 V DC \pm 5% and up to 3 A DC current to the Cheetah POE camera with a P-Iris lens. The operating input voltage ranges from 100 to 240 V AC.

The PS12V18A power supply is comprised of three components:

Item	Qty.
PS12V10 Universal Power Supply	1
CBL-PWR-0018 I/O and Power Cable	1
Power Cord	1

The CBL-PWR-0018 cable terminates in a female Hirose type miniature locking plug #HR10A-10P-12S(73). It has two BNC pig-tail cables providing external trigger input (black) and strobe output (white). It also features a lens control cable terminated with a female P-Iris plug.

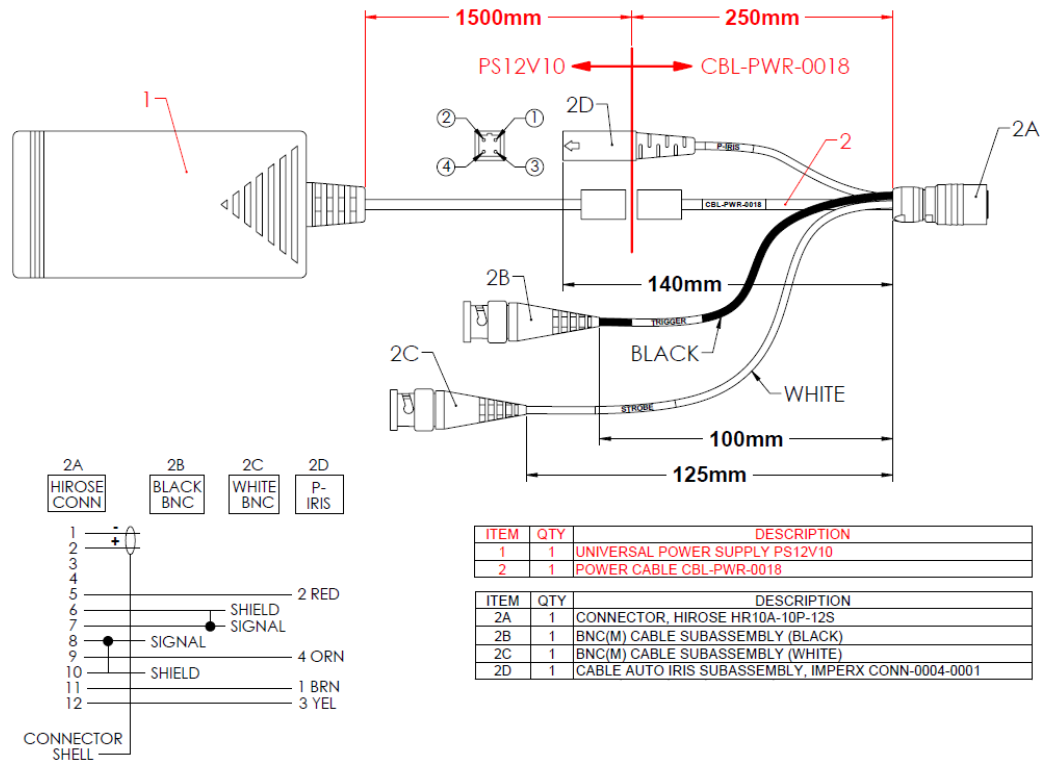

PS12V14A / PS12V18A Specifications

Specifications		Description
Input		
Voltage		100–240 V AC
Frequency		50–60 Hz
Current		1 A max
Inrush Current		70 A max / 230 V AC (cold start @ 25 °C, full load)
Efficiency		Eff (av) ≥ 87.4 % (at 115 V AC & 230 V AC) Eff ≥ 78.303 % (at 230V/50Hz input @10% load for CoC Tier2)
Output		
Voltage		11.4 V to 12.6 V DC, 12 V DC nominal
Current		3 A max
Load Regulation		± 5%
Ripple & Noise		1% Vpp max for Output Voltage @ full load
Total Power		36 W Max
Protection		
Over-Voltage Protective (OVP)		V out * 180% (max)
Short-Circuit Protective (SCP)		Automatic recovery after short circuit fault being removed
Over Current Protection (OCP)		I out * 200% (max)
Safety, EMI and EMC Requirement		
Safety		UL, CUL, GS, PSE, BSMI, CB, RCM, CCC, KC, LPS
Dielectric Strength		10 mA max. cut off current (1) Primary to Secondary: 3000 V AC for 1 minute (2) Primary to Frame Ground: 1500 V AC for 1 minute
Insulation Resistance		(1) Primary to Secondary: 10 MOhm for 500 V DC (2) Primary to Frame Ground: 10 MOhm for 500 V DC
EMI Requirement		CE, FCC Class B, Conduction and Radiation meet
Leakage Current		Less than 3.5 mA
Grounding Test		Resistance 0.1 Ohm max @ 32 A
Environmental	Operating Storage	0 °C to +40 °C -20 °C to +80 °C
Relative humidity	Operating Storage	20% to 80% non-condensing 10% to 90% non-condensing
Regulatory		DoE VI, ErP (Lot 7), GEMS, NRCAN, CEC, RoHS
Cable Length		
Supplied AC power input cable (IEC)		1.8 m (6')
Power supply output (+12 V)		1.75 m (5') ± 15 cm (6"), connector HIROSE #HR10A-10P-12S
Strobe		12.5 cm (5") ± 1 cm (0.4") connector BNC male
Trigger		10 cm (4") ± 1 cm (0.4") connector BNC male
P-Iris (for CBL-PWR-0018)		14.4 cm (5.7") ± 1 cm (0.4")

Connecting the PS12V14A / PS12V18A Power Supply

1. Connect a power cord to the PS12V10 power adapter.
2. Connect the KPPX-4P plug of the PS12V10 power adapter to the KPJX-CM-4S socket of the CBL-PWR-0014/CBL-PWR-0018 cable.

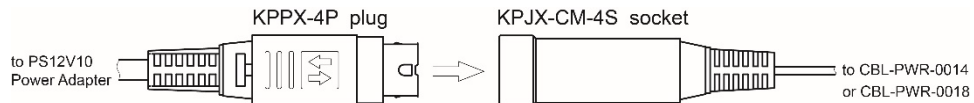

CAUTION

Push connectors together until the locking mechanism clicks, and there is no gap between the connectors. If connectors are not securely locked, overheating may occur resulting in damage to the cable or leading to fire.

Correct position

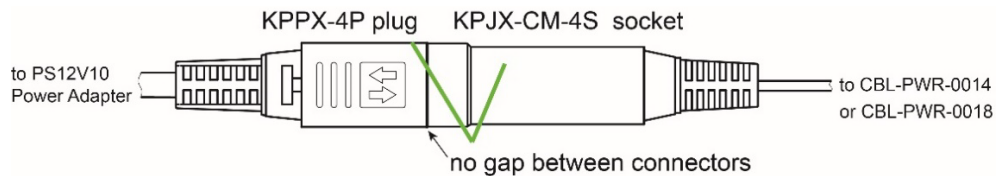

Incorrect position

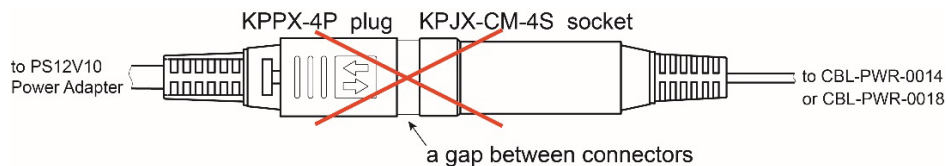

3. Connect the other end of the CBL-PWR-0014 / CBL-PWR-0018 cable to the Cheetah POE camera.
4. If applicable, connect Trigger and Strobe cables to external devices, if applicable.
5. Connect the P-Iris jack to a P-Iris lens (PS12V18A power supply only).

CAUTION

To disconnect the CBL-PWR-0014 or CBL-PWR-0018 cable from the PS12V10 power adapter, pull on the plug KPPX-4P. Do not pull on the cable. Doing so may result in damage to the cable.

PS12V14A Connection Diagram

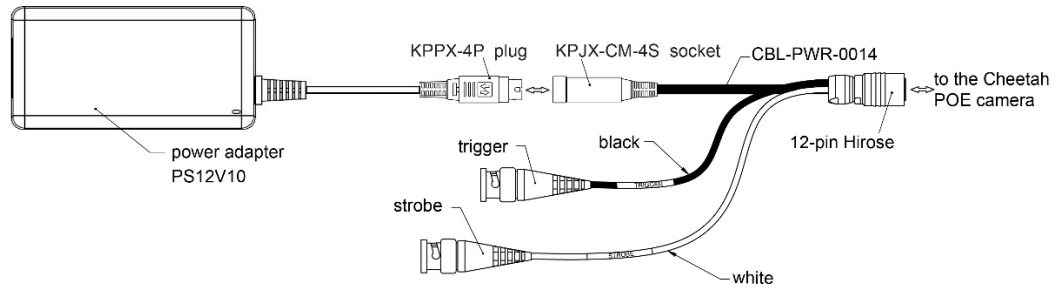

PS12V18A Connecting Diagram

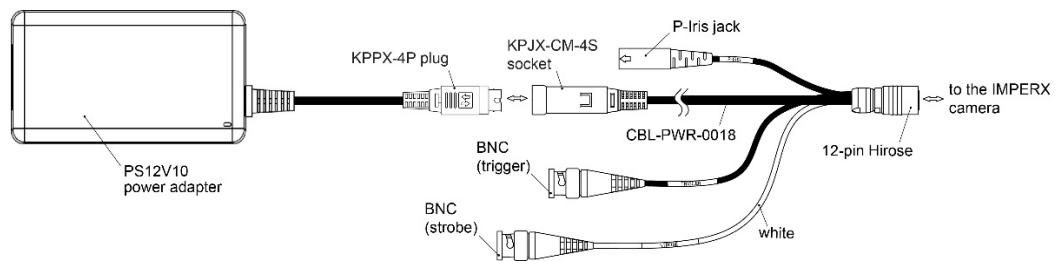

Power and I/O cable CBL-COM01

The optionally purchased CBL-COM01 cable is used with C2000 and C2400 cameras for transmitting power, external trigger and strobe signals. It terminates in a female HIROSE plug #HR10A-7P-6S(73) on one end and 6 loose wires on the opposing.

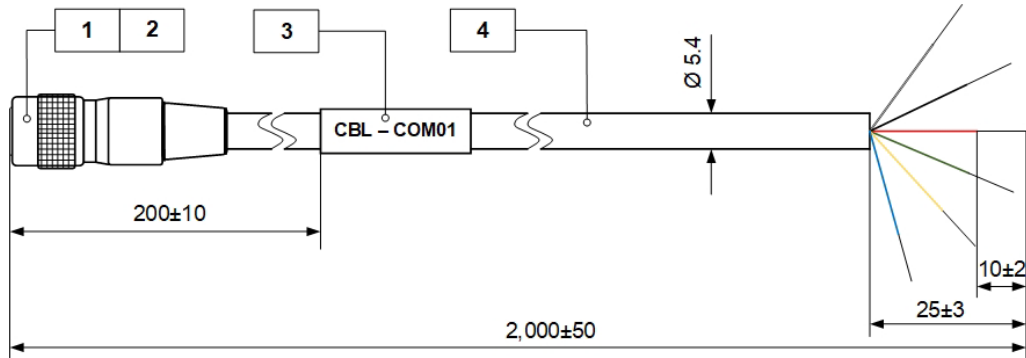

Hirose
HR10A-7P-6S(73)
Rear view



Pin	Wire color	Signal
1	White	+12 V DC
2	Black	IN1 (OPTO)
3	Red	IN1 RTN (OPTO)
4	Green	OUT1 (OPTO)
5	Yellow	OUT1 RTN (OPTO)
6	Blue	+12 V DC RTN

Unit	Item	QTY	Description
mm	1	1	Hirose HR10A-7P-6S(73)
	2	6	Shrinking tube Ø 1.5 mm x 8 mm
	3	1	Shrinking label Ø 6 mm x 30 mm
	4	1	Cable Ø 5.4 mm, 2 meters

I/O Cable CBL-PWIO01

The optionally purchased CBL-PWIO01 cable is used with POE-C1911, POE-C2010, POE-C2410, POE-C2410Y/Z, POE-C3210, POE-C4010, POE-C4110, POE-C4110YZ, POE-C4410, POE-C5410, POE-C6410, POE-C4410-T, POE-C5410-T, and POE-C6410-T cameras for transmitting external trigger and strobe signals when the camera is powered using Local Area Network power or an external POE injector. It terminates in a female HIROSE plug #HR10A-10P-12S(73) on one end and 12 loose wires on the opposing.

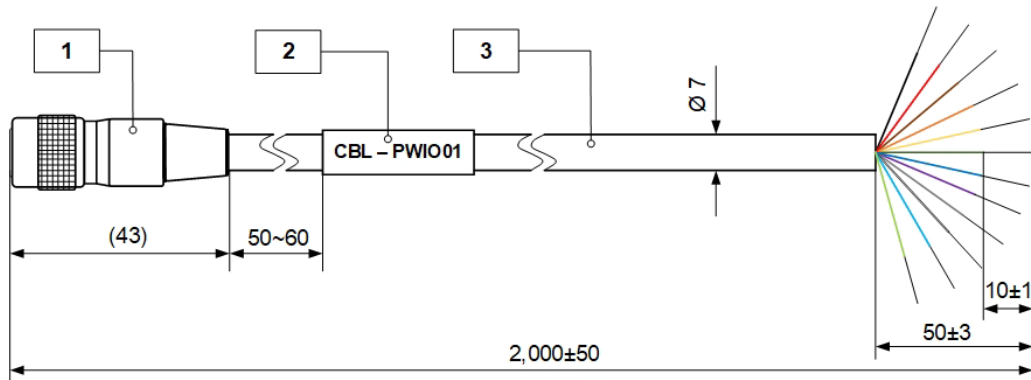

Hirose
HR10A-10P-12S(73)
Rear view

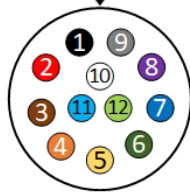

Pin	Wire color	Signal
1	Black	12 V DC RTN
2	Red	+12 V DC
3	Brown	Reserved
4	Orange	Reserved
5	Yellow	OUT2 RTN (OPTO)
6	Green	OUT1 RTN (TTL)
7	Blue	OUT1 (TTL)
8	Violet	IN1 (OPTO)
9	Gray	IN2 (TTL/LVTTL)
10	White	IN1 RTN (OPTO)
11	Sky Blue	IN2 RTN (TTL)
12	Yellowish Green	OUT2 (OPTO)

} alternative power
(connect if applicable)

Unit	Item	QTY	Description
mm	1	1	Hirose HR10A-10P-12S(73)
	2	1	Shrinking label Ø 8 mm x 30 mm
	3	1	Cable Ø 7 mm, 2 meters

IP-67 rated Power and I/O Cable CBL-IO08-0001

The optionally purchased CBL-IO08-0001 cable is used with the P67-C1911, P67-C2010, P67-C2410, P67-C3210, P67-C4010, P67-C4110 cameras for transmitting power, external trigger and strobe signals. It terminates in a female plug BULGIN PXPTPU12FBF08ACL020PUR on one end and 8 loose wires on the opposing.

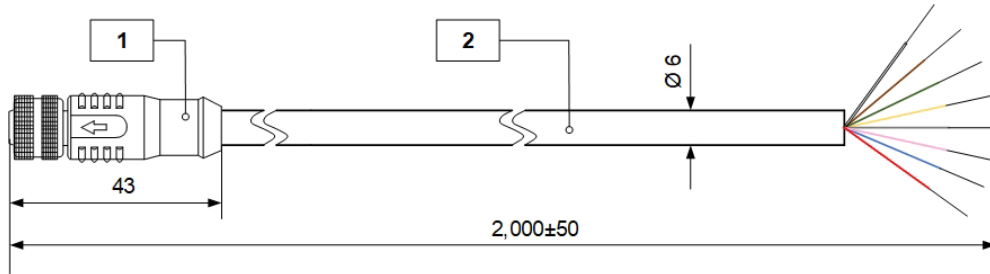

BULGIN
PXPTPU12FBF08ACL020PUR



Pin	Signal	Wire color
1	Reserved	White
2	+12 V DC	Brown
3	IN1 (OPTO)	Green
4	IN1/OUT1 RTN	Yellow
5	OUT2 RTN (TTL)	Grey
6	OUT1 (OPTO)	Pink
7	12 V DC RTN	Blue
8	OUT 2 (TTL)	Red

Unit	Item	QTY	Description
mm	1	1	BULGIN PXPTPU12FBF08ACL020PUR
	2	1	Cable Ø 6 mm, 2 meters

IP-67 Rated Gigabit Ethernet Cables CBL-XRJ45-00XX

The optionally purchased Gigabit Ethernet cable CBL-XRJ45-00XX meets EIA/TIA standards and is used with the P67-C1911, P67-C2010, P67-C2410, P67-C3210, P67-C4010, and P67-C4110 cameras. The cable terminates in an M12 8-pin male plug on one end and RJ45 straight connector on the opposing.

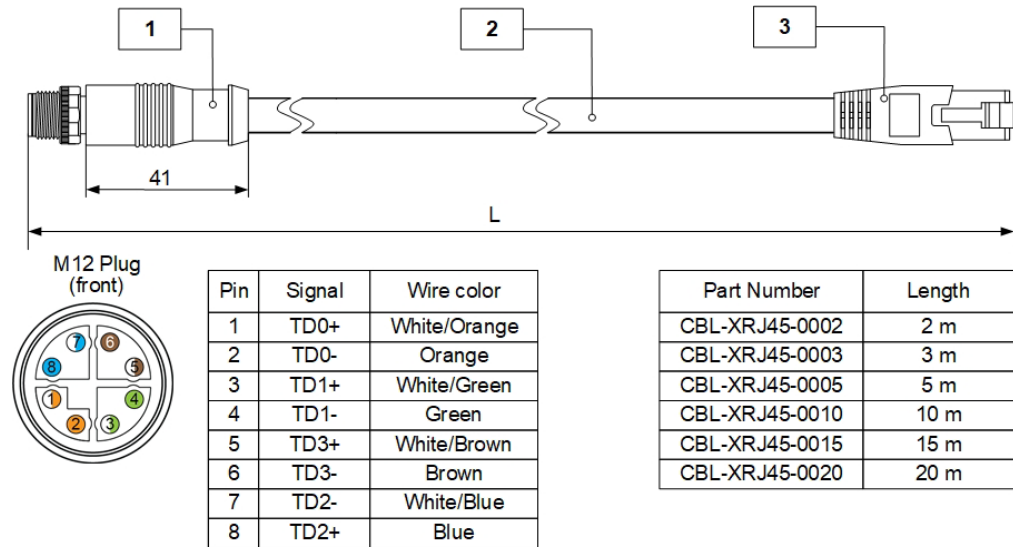

Unit	Item	QTY	Description
mm	1	1	M12 X-coded 8-position male plug
	2	1	CAT 6a cable, length varies
	3	1	RJ45 jack

Active Canon EF mount

The Canon EF lens mount provides active lens control for C4410, C5410, and C6410 cameras. The cameras provide communication and power to the mount through an internal connector on the front of the camera. The connector eliminates the need for a special power supply and external cable between the camera and the Canon EF mount.

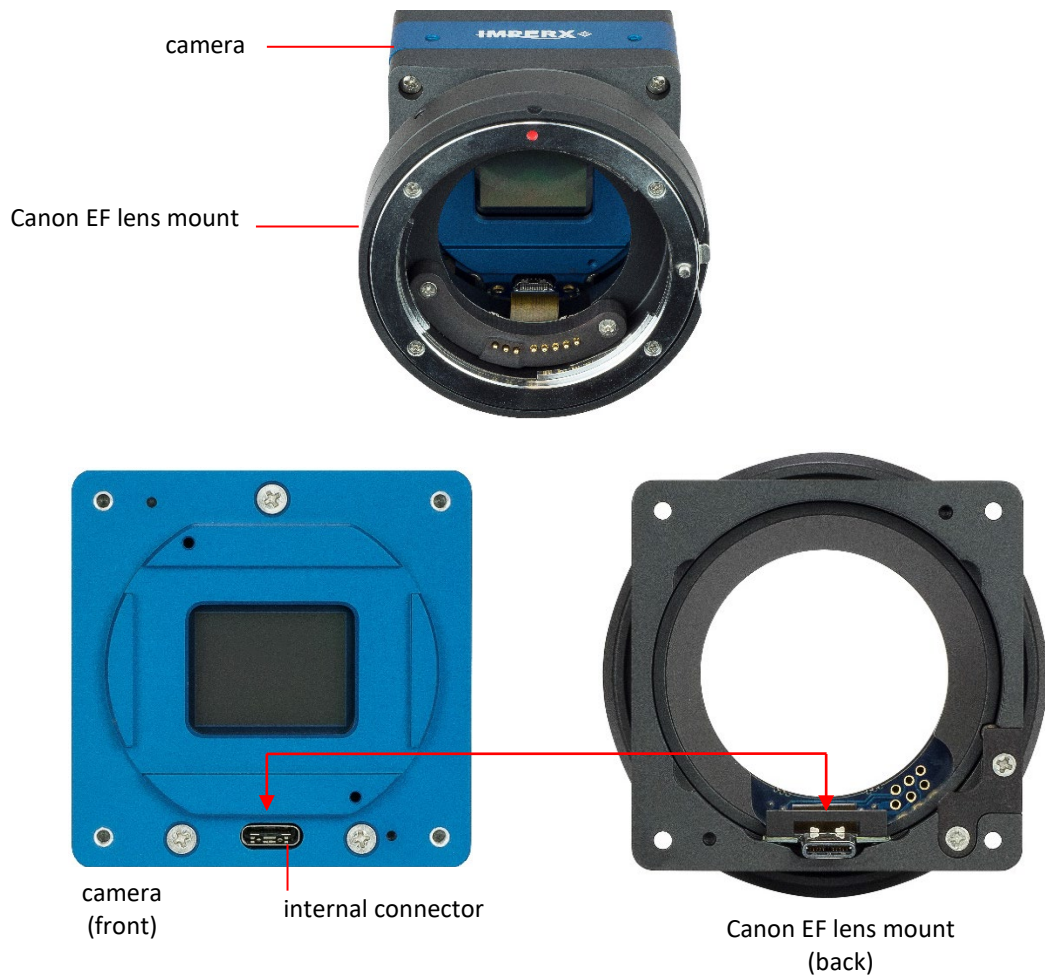

Electrical Connectivity

The number of external inputs and outputs vary between different Cheetah cameras. Depending on camera model, type of the available inputs or outputs (opto-isolated or TTL and opto-isolated) may differ as well. The following table shows what inputs and outputs are available for a particular camera model.

Camera model	Inputs				Outputs			
	Opto-isolated		TTL/LVTTL		Opto-isolated		TTL	
	Name	Pin#	Name	Pin#	Name	Pin#	Name	Pin#
POE-C2000, POE-C2400	IN1	2	N/A	N/A	OUT1	4	N/A	N/A
	IN1 RTN	3			OUT1 RTN	5		
P67-C1911	IN1	3	N/A	N/A	OUT1	6	OUT2	8
P67-C2010, P67-C2410, P67-C3210, P67-C4010, P67-C4110	IN1 RTN	4			OUT1 RTN	4	OUT2 RTN	5
POE-C1911	IN1	8	IN2	9	OUT2	5	OUT1	7
POE-C2010, POE-C2410, POE-C3210, POE-C4010, POE-C4110, POE-C4410, POE-C5410, POE-C6410, POE-C4410-T, POE-C5410-T, POE-C6410-T	IN1 RTN	10	IN2 RTN	11	OUT2 RTN	12	OUT1 RTN	6

The electrical connections of external inputs and outputs are similar for all Cheetah cameras. For more information see sections [Opto-Isolated Input](#), [TTL/LVTTL Input](#), [TTL Output](#), and [Opto-Isolated Output](#).

Opto-Isolated Input

Input signals IN1 and IN1 RTN are optically isolated. The voltage difference between the two must be positive between 3.3 V and 24 V. The minimum input current is 3.3 mA.

Input IN1 pin numbers may vary for different camera models (refer to the table above).

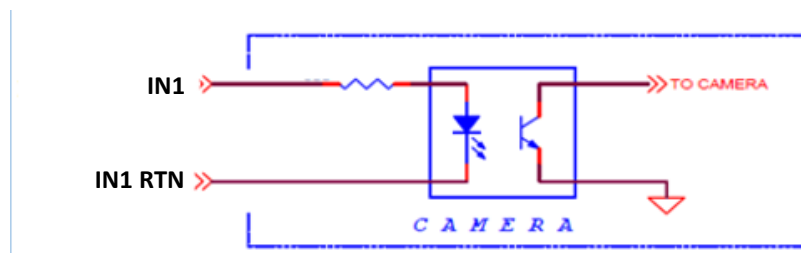

TTL/LVTTL Input

Input signals IN2 and IN2 RTN provide interfaces to a TTL or LVTTL input signal. The signal level (voltage difference between the inputs IN2 and IN2 RTN) **must be** LVTTL (3.3 V) or TTL (5.0 V). The total maximum input current **must not** exceed 2.0 mA.

Input IN2 pin numbers may vary for different camera models (refer to the table on the page 53).

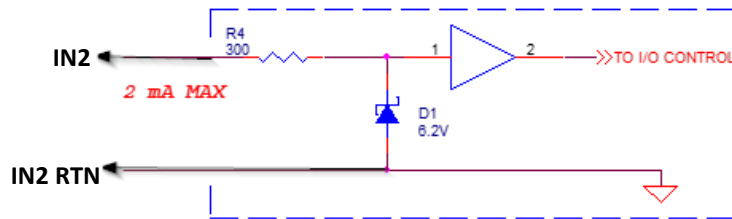

TTL Output

TTL output provides interface to a TTL compatible output signal. The signal level (voltage difference between the outputs OUT and OUT RTN) is TTL (5.0 V). The maximum output current **must not** exceed 8.0 mA.

Output name (OUT1 or OUT2) and pin numbers of different cameras may vary (refer to the table on the page 53).

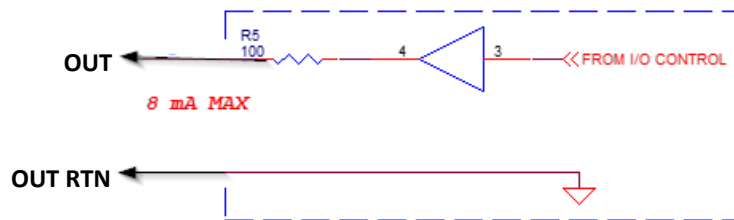

Opto-Isolated Output

Opto-isolated output is an optically isolated switch. There is no pull-up voltage on either contact. Depending on camera model, an external pull-up voltage of up to 18 V or 25 V is required for operation (see the table below). The output is not polarity sensitive. AC or DC loads are possible.

The voltage across opto-isolated contacts **must not** exceed 18 V (for POE-C2000, POE-C2400, P67-C1911, P67-C2010, P67-C2410, P67-C3210, P67-C4010, P67-C4110, POE-C4410, POE-C5410, POE-C6410, POE-C4410-T, POE-C5410-T, POE-C6410-T) or 25 V (for POE-C1911, POE-C2010, POE-C2410, POE-C3210, POE-C4010, POE-C4110).

The current through the switch **must not** exceed 50 mA. ‘On’ resistance is less than 5 Ohms.

Camera model	Opto-Isolated Outputs		Max. Voltage	Max. Current
	Name	Pin#		
POE-C2000, POE-C2400	OUT1	4	18 V (DC or peak AC)	50 mA
	OUT1 RTN	5		
P67-C1911, P67-C2010, P67-C2410, P67-C3210, P67-C4010, P67-C4110	OUT1	6	18 V (DC or peak AC)	50 mA
	OUT1 RTN	4		
POE-C4410, POE-C5410, POE-C6410, POE-C4410-T, POE-C5410-T, POE-C6410-T	OUT2	5	18 V (DC or peak AC)	50 mA
	OUT2 RTN	12		
POE-C1911, POE-C2010, POE-C2410, POE-C3210, POE-C4010, POE-C4110	OUT2	5	25 V (DC or peak AC)	50 mA
	OUT2 RTN	12		

Output name (OUT1 or OUT2) and pin numbers of different cameras may vary (refer to the table on the page 53).

Open drain logic driver circuit

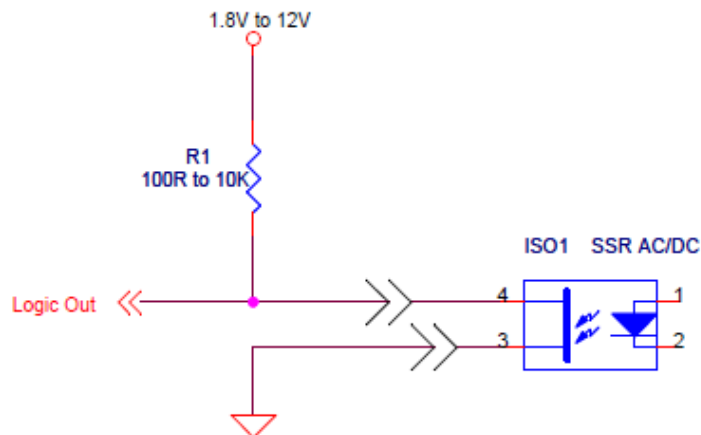

Low side load driver circuit

V_s 18 Vmax or 25 Vmax DC or peak AC

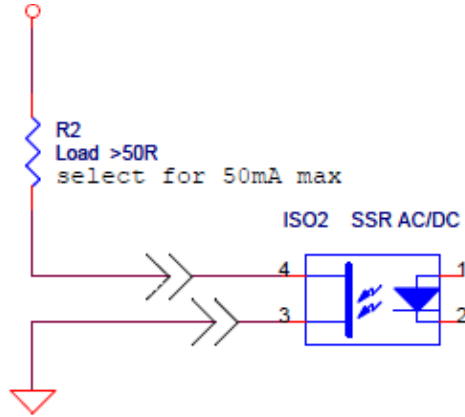

High side load driver circuit

V_s 18 Vmax or 25 Vmax DC or peak AC

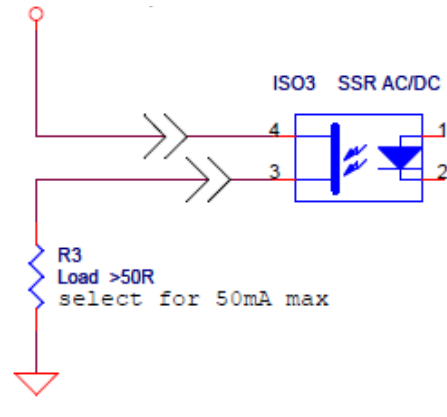

Camera model: POE-C2000, POE-C2400, P67-C1911, P67-C2010, P67-C2410, P67-C3210, P67-C4010, P67-C4110, POE-C4410, POE-C5410, POE-C6410, POE-C4410-T, POE-C5410-T, POE-C6410-T

Voltage, V_s	from 2.5 V to 18 V (DC or peak AC)
----------------	------------------------------------

Load resistance, R2 or R3	from 50 R to 360 R
---	--------------------

Load current, I_L	from 1 mA to 50 mA
---------------------	--------------------

Camera model: POE-C1911, POE-C2010, POE-C2410, POE-C3210, POE-C4010, POE-C4110

Voltage, V_s	from 2.5 V to 25 V (DC or peak AC)
----------------	------------------------------------

Load resistance, R2 or R3	from 50 R to 500 R
---	--------------------

Load current, I_L	from 1 mA to 50 mA
---------------------	--------------------

Mechanical Drawings

Camera model	Camera size (W x H x L)	Mounting holes		
		Size	Qty.	Location
POE-C2000, POE-C2400	29 x 29 x 59.4 mm	M3 x 0.5mm 3.0 mm deep	3	3 holes on the bottom side
POE-C1911, POE-C2010, POE-C2410, POE-C2410Y/Z, POE-C3210, POE-C4010, POE-C4110	37 x 37 x 61.6 mm	M3 x 0.5mm 4.5 mm deep	8	2 holes on each side
P67-C1911, P67-C2010, P67-C2410, P67-C3210, P67-C4010, P67-C4110	48.5 x 42 x 61 mm (without a lens tube)	M3 x 0.5mm 4.0 mm deep	4	2 holes on the top and bottom sides
POE-C4410, POE-C5410, POE-C6410	60 x 60 x 56.5 mm	M3 x 0.5mm 5.0 mm deep	8	2 holes on each side
POE-C4410-T, POE-C5410-T, POE-C6410-T	60 x 64.4 x 70 mm	M3 x 0.5mm 5.0 mm deep	8	2 holes on each side

C2000 and C2400 Cameras

The camera housing is made of precision-machined aluminum. For maximum flexibility, the camera has three M3X0.5mm mounting holes located on the bottom side. An additional mounting plate with ¼-20 UNC (tripod mount) and hardware ship with each camera.

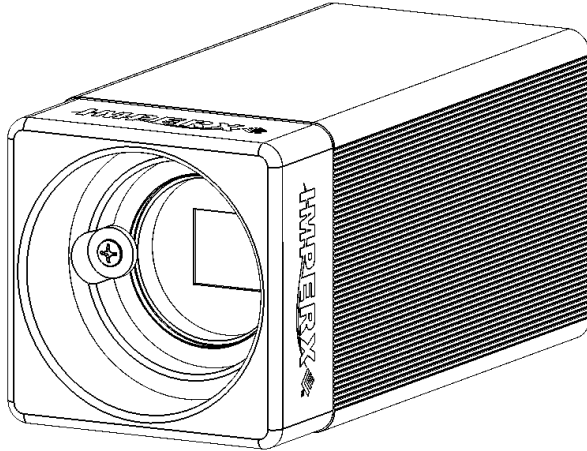

Front View:

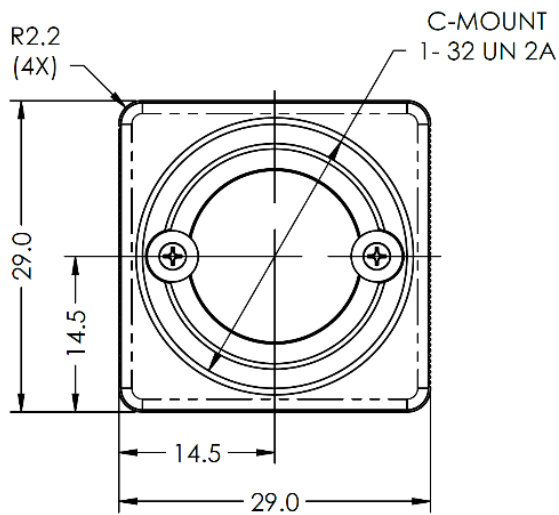

Back View:

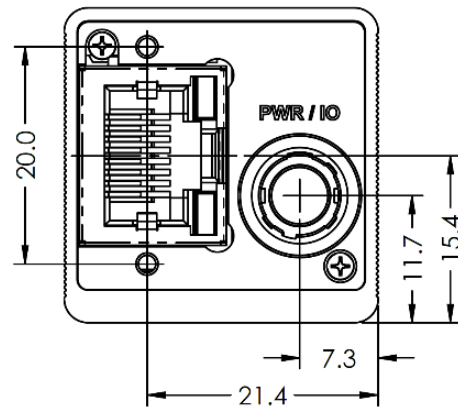

Bottom View:

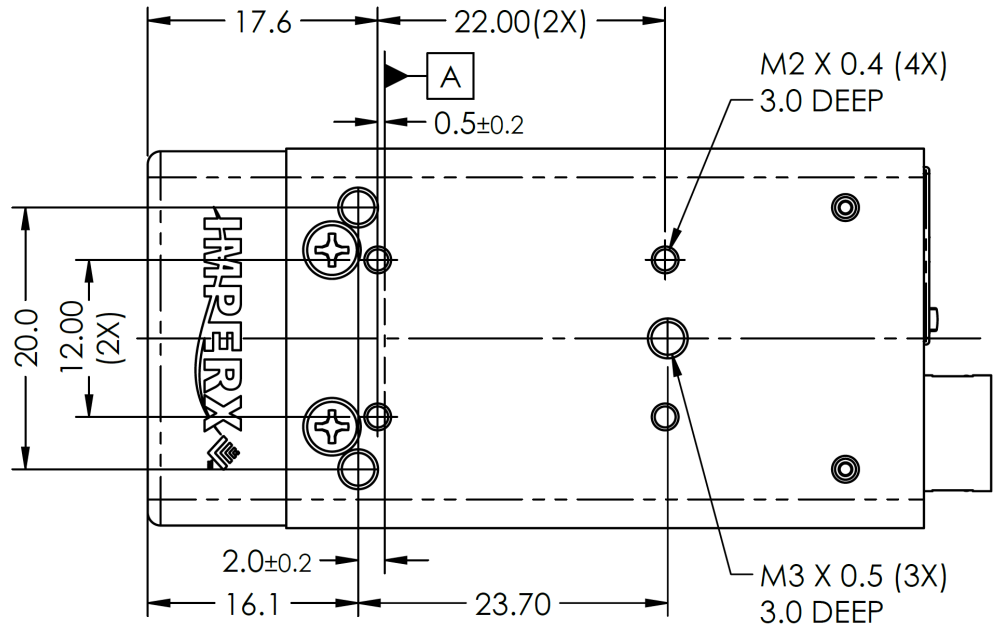

Side View with Image Plane:

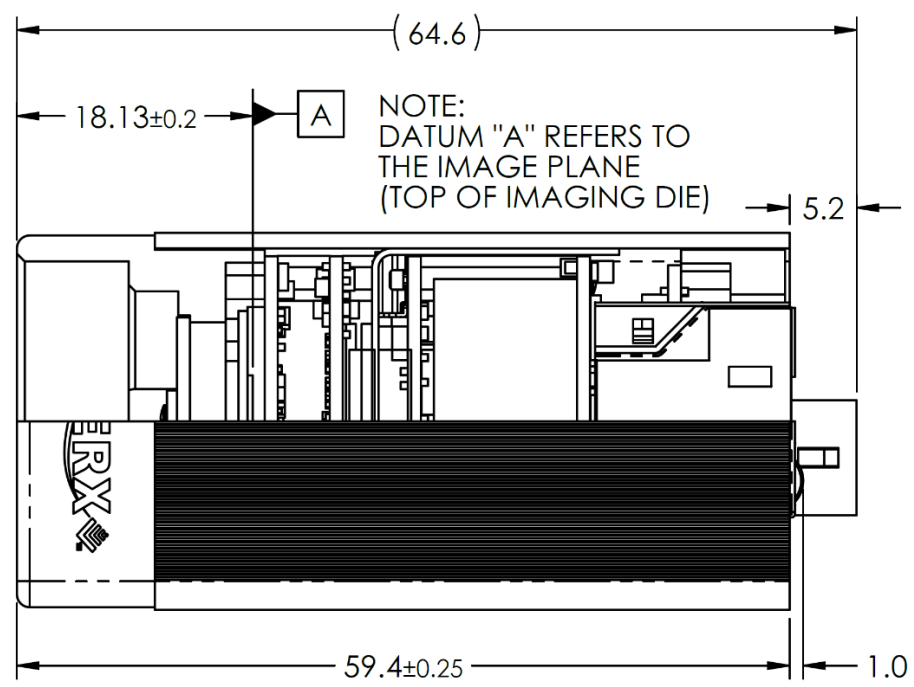

C2000 and C2400 Cameras Mounting Plate

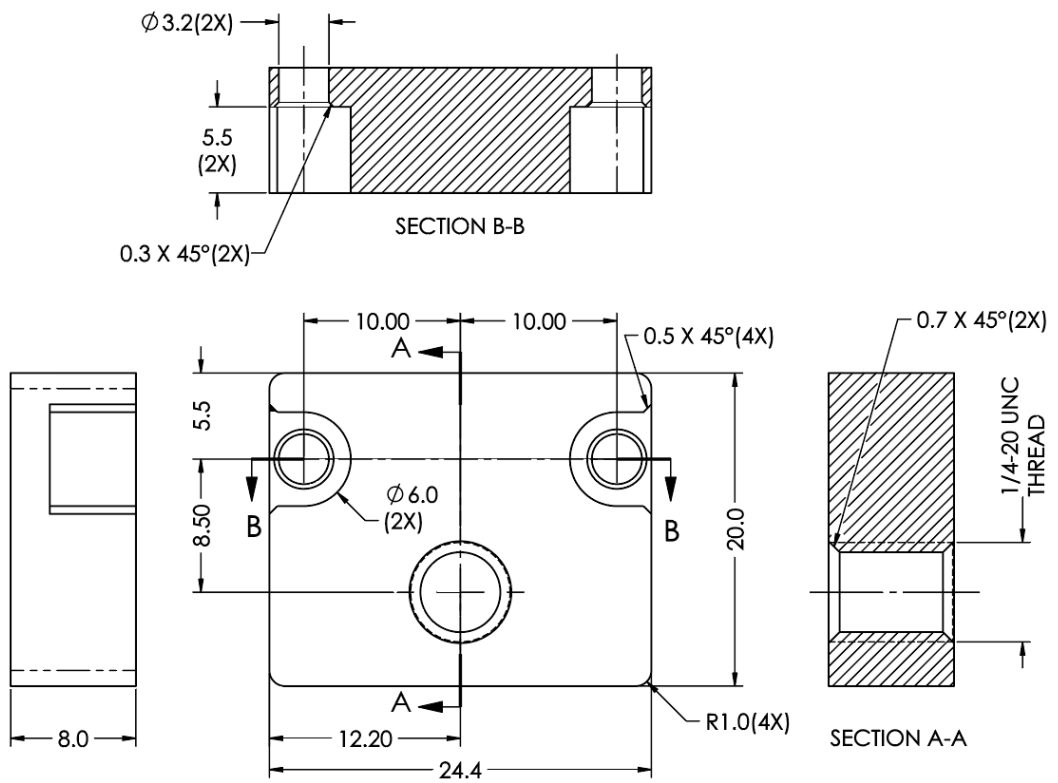

POE-C1911, POE-C2010, POE-C2410, POE-C3210, POE-C4010, and POE-C4110 Cameras

The camera housing is made of precision-machined aluminum. For maximum flexibility, the camera has eight M3X0.5mm mounting holes located towards the front of the camera on all four sides. An additional plate with ¼-20 UNC (tripod mount) and hardware ship with each camera.

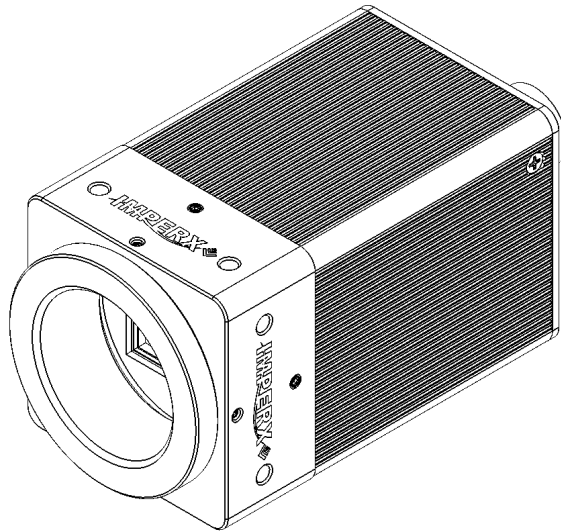

Front View:

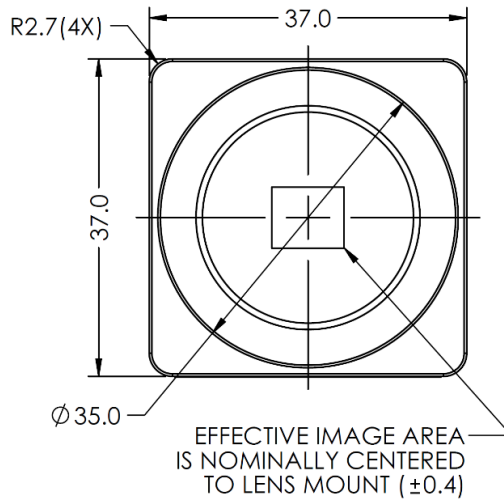

Back View:

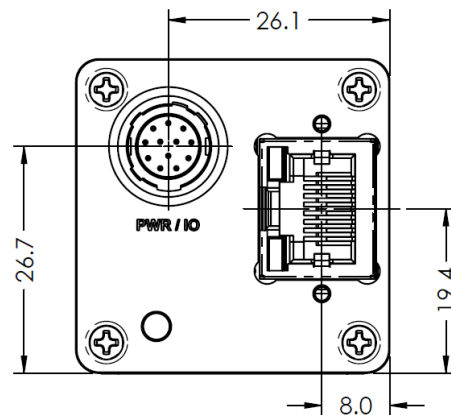

Top View:

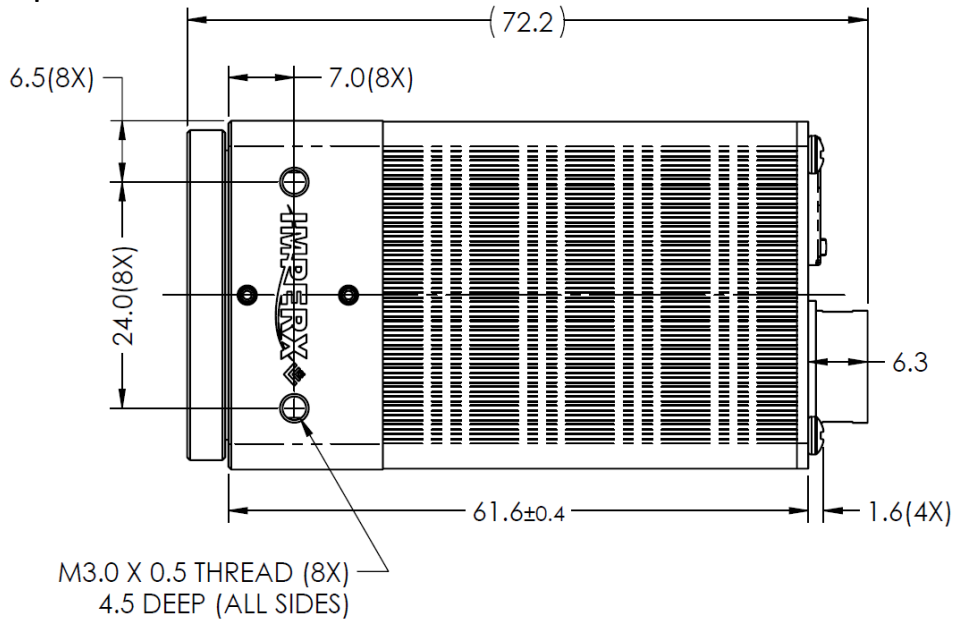

Side View with Image Plane:

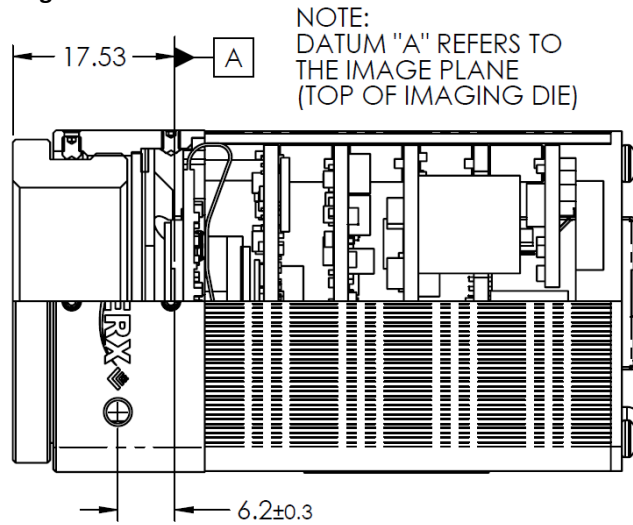

POE-C1911, POE-C2010, POE-C2410, POE-C2410, POE-C3210, POE-C4010, and POE-C4110 Cameras Mounting Plate

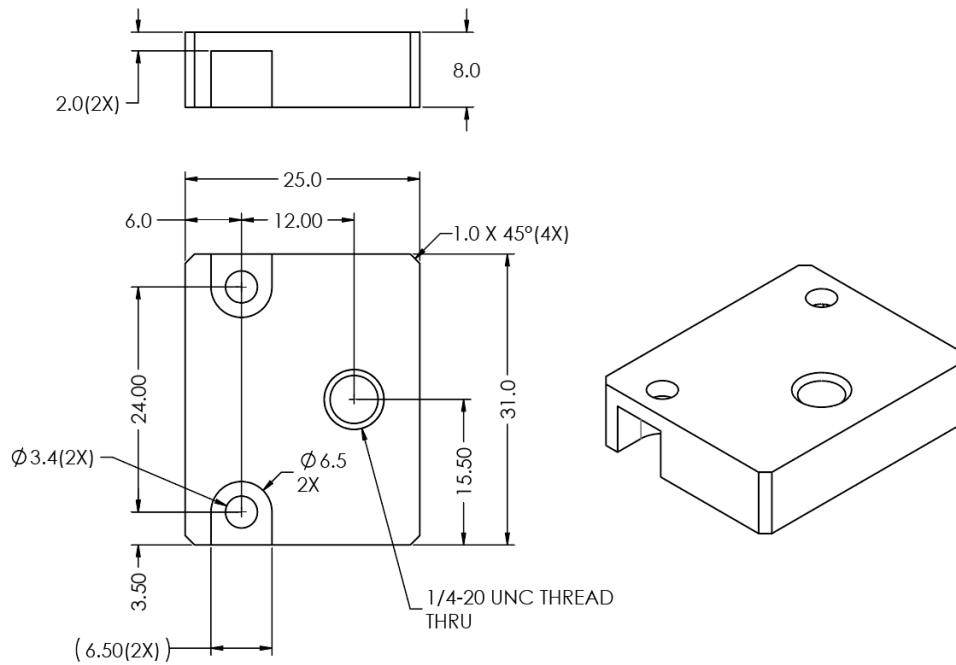

C4410, C5410, and C6410 Cameras

The camera housing is made of precision-machined aluminum. For maximum flexibility, the camera has eight M3X0.5mm mounting holes located towards the front of the camera on all four sides. An additional plate with ¼-20 UNC (tripod mount) and hardware ship with each camera.

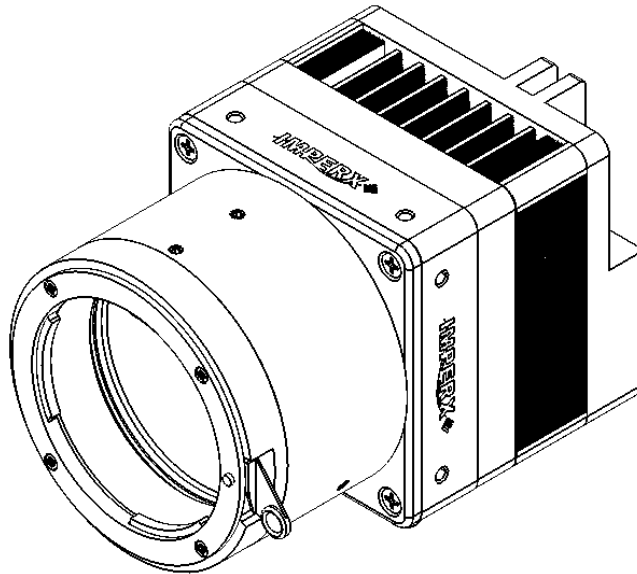

Front View:

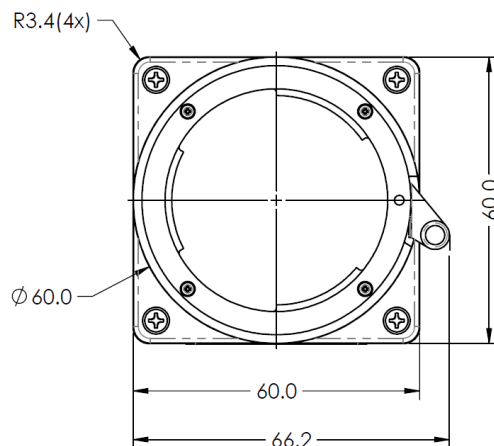

Back View:

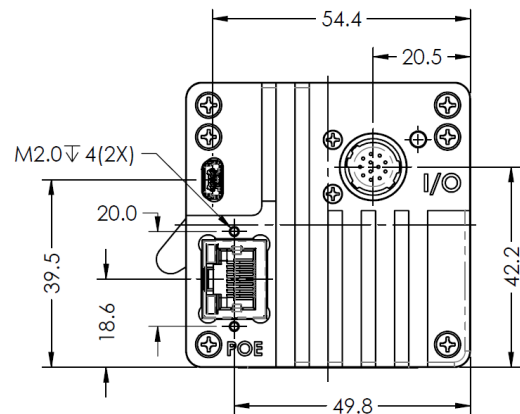

Top View:

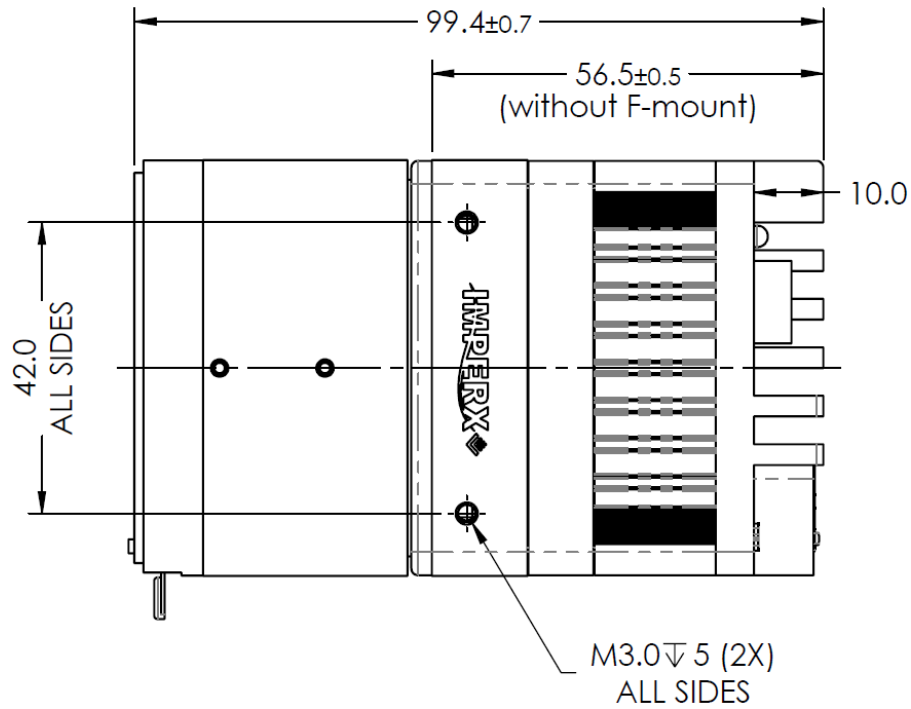

Side View with Image Plane:

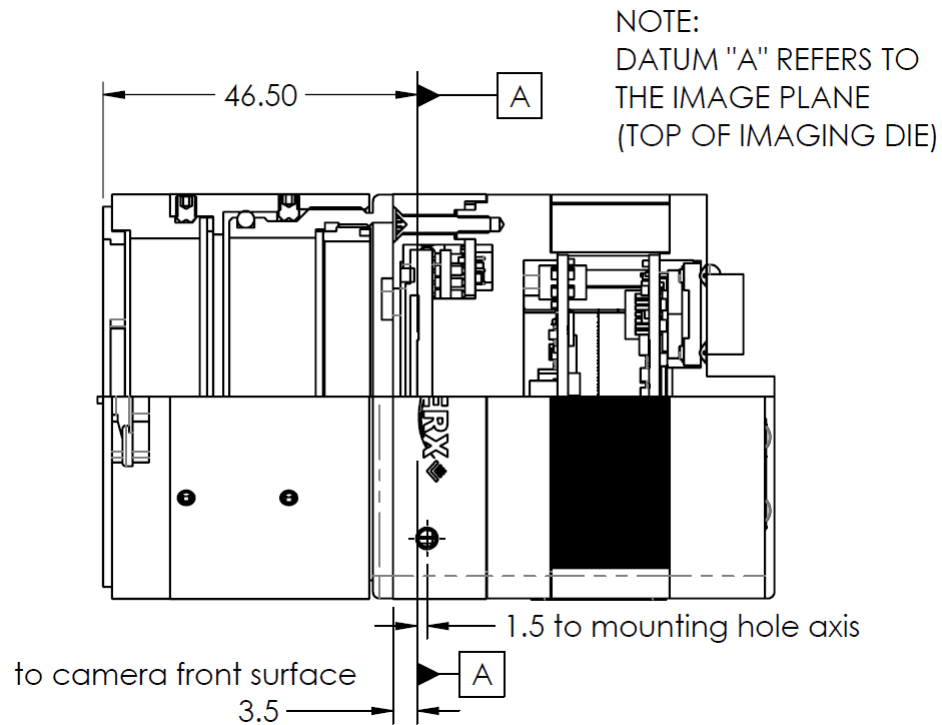

C4410, C5410, C6410, C4410-T, C5410-T, and C6410-T Cameras Mounting Plate

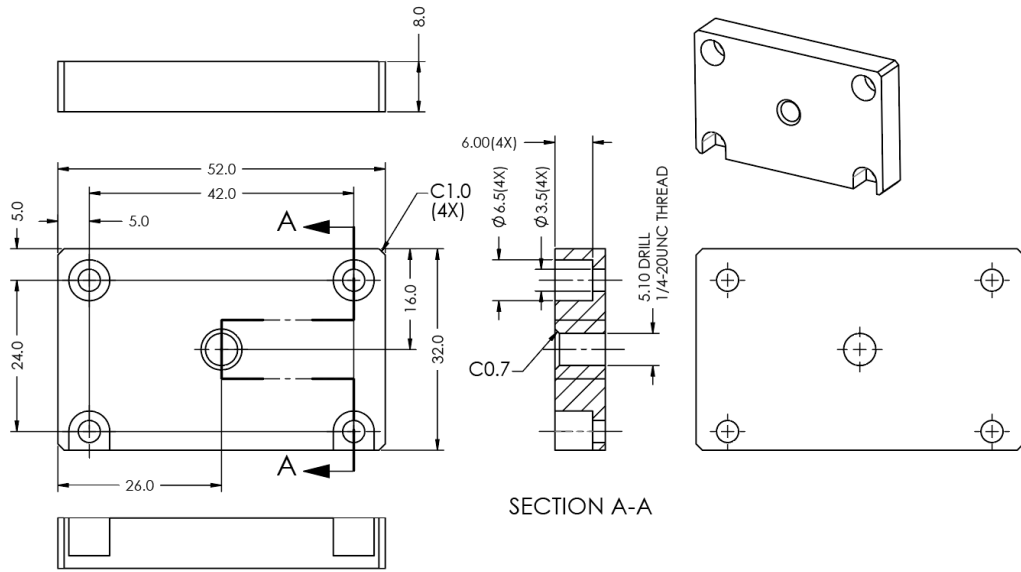

C4410-T, C5410-T, and C6410-T Cameras

The camera housing is made of precision-machined aluminum. For maximum flexibility, the camera has eight M3X0.5mm mounting holes located towards the front of the camera on all four sides. An additional plate with ¼-20 UNC (tripod mount) and hardware ship with each camera.

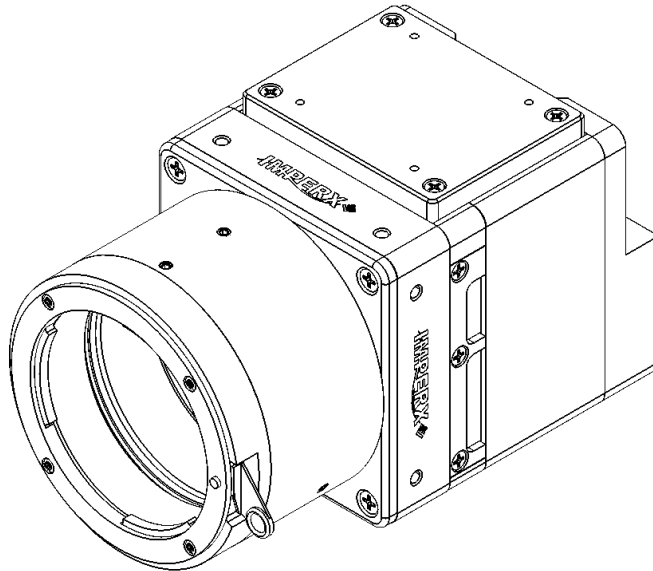

Front View:

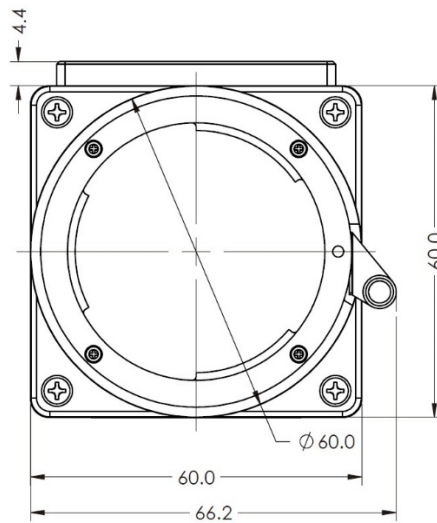

Back View:

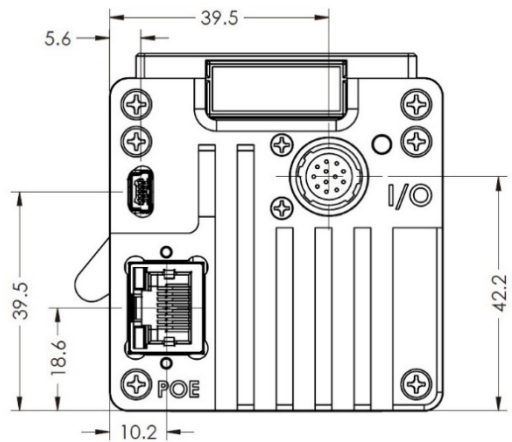

Top View:

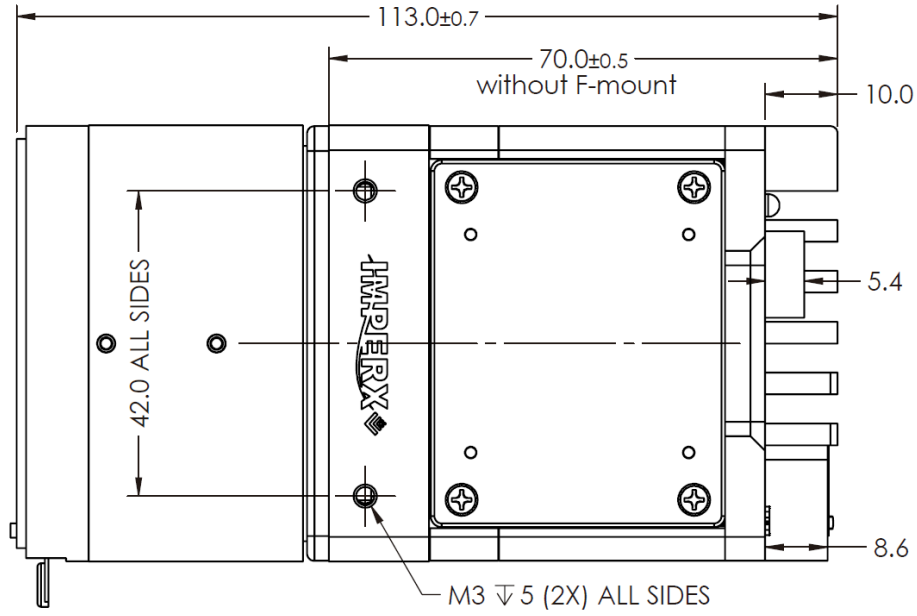

Side View with Image Plane:

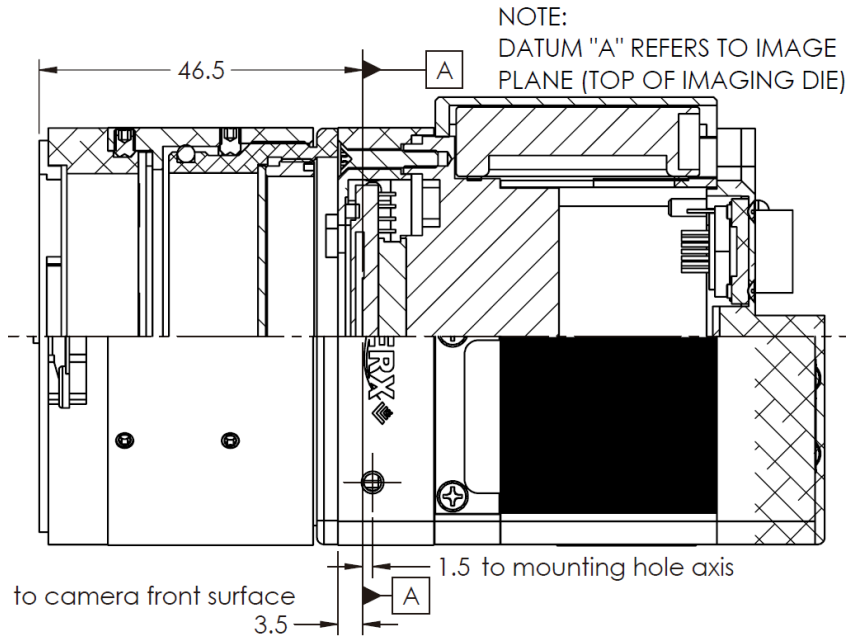

P67 Cheetah Cameras

The camera housing is made of precision-machined aluminum. For maximum flexibility, the camera has four M3X0.5mm mounting holes located towards the front of the camera on the top and bottom sides. An additional plate with ¼-20 UNC (tripod mount) and hardware ship with each camera.

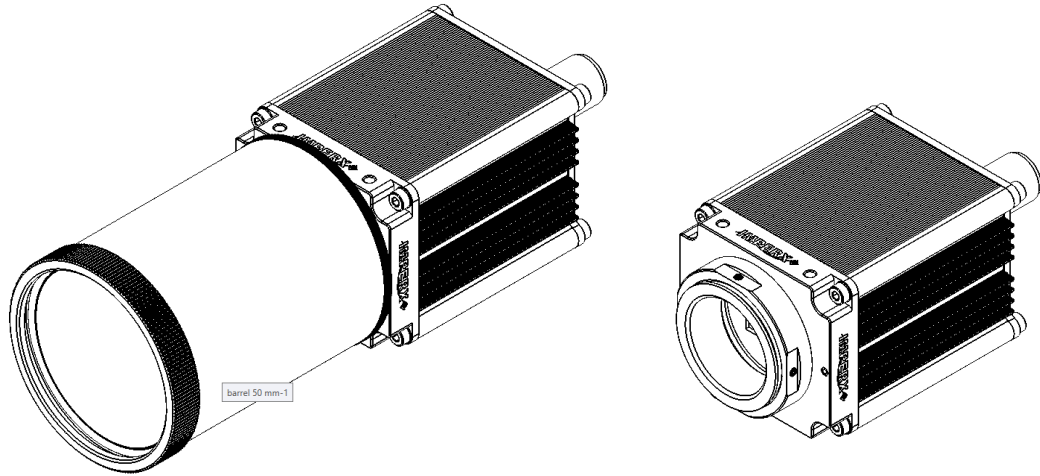

Front View:

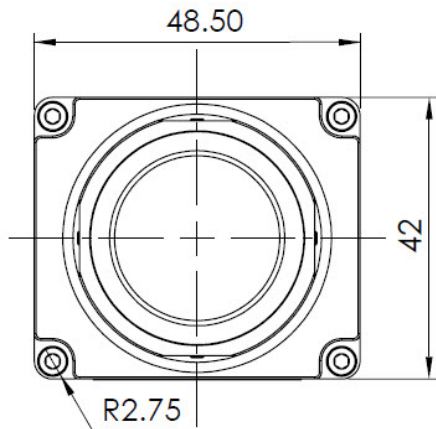

Back View:

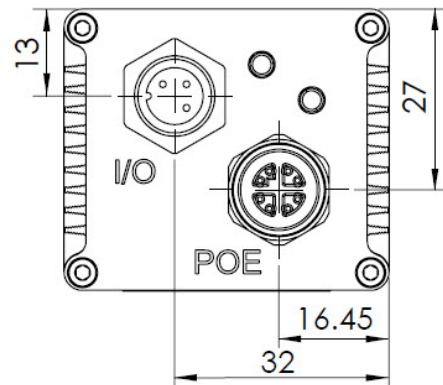

Top view:

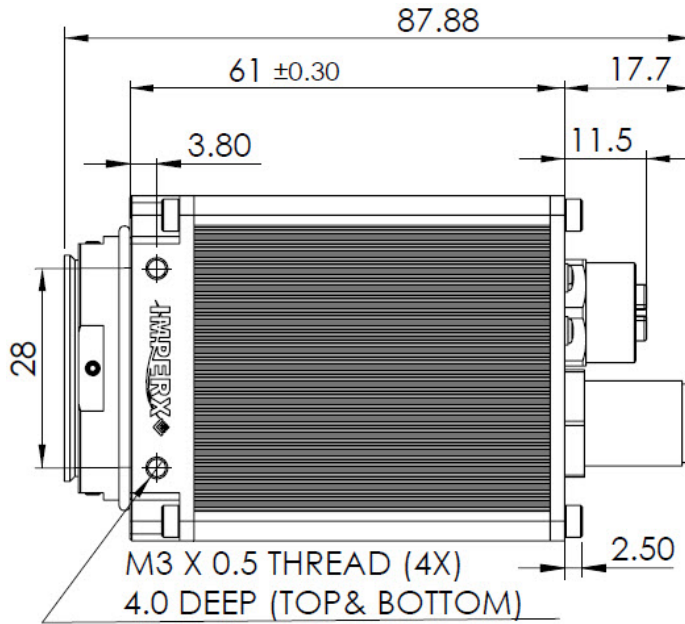

Section A – A:

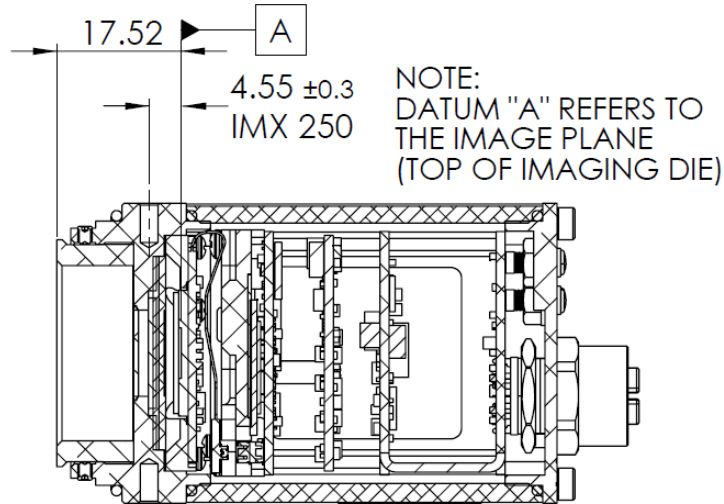

IP67 C-Mount Lens Tubes (inner diameter 44 mm)

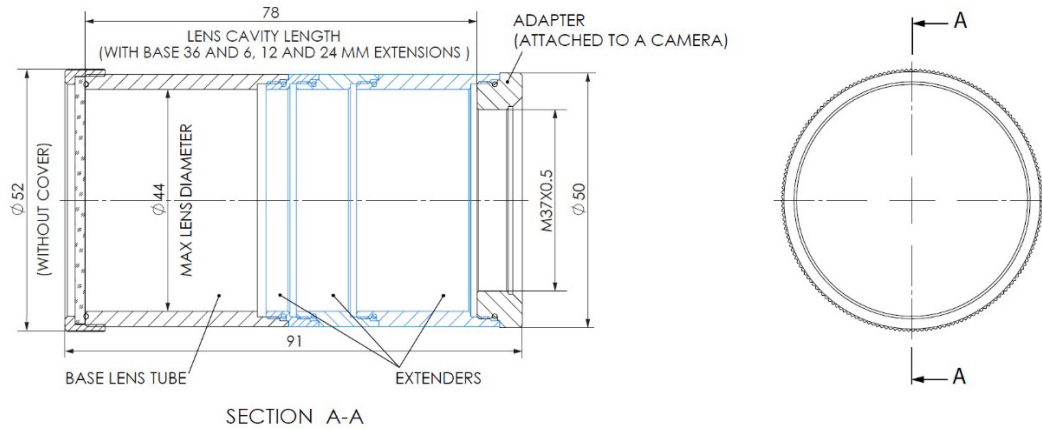

Part Number	Inner Length	Inner Diameter	Outer Diameter	Glass	Housing Material
Tube-44MM-0036 (default)*	36 mm	Ø 44 mm	Ø 50 mm	Clear Glass, Ø 49 mm x 2 mm, with oleophobic coating	Aluminum
Tube-44MM-0042	42 mm				
Tube-44MM-0048	48 mm				
Tube-44MM-0054	54 mm				
Tube-44MM-0060	60 mm				
Tube-44MM-0066	66 mm				
Tube-44MM-0072	72 mm				
Tube-44MM-0078	78 mm				

*Custom Tube Lengths are available, please contact your local distributor or Imperx sales at +1-561-989-0006 or sales@imperx.com.

IP67 C-Mount Lens Tubes (inner diameter 64 mm)

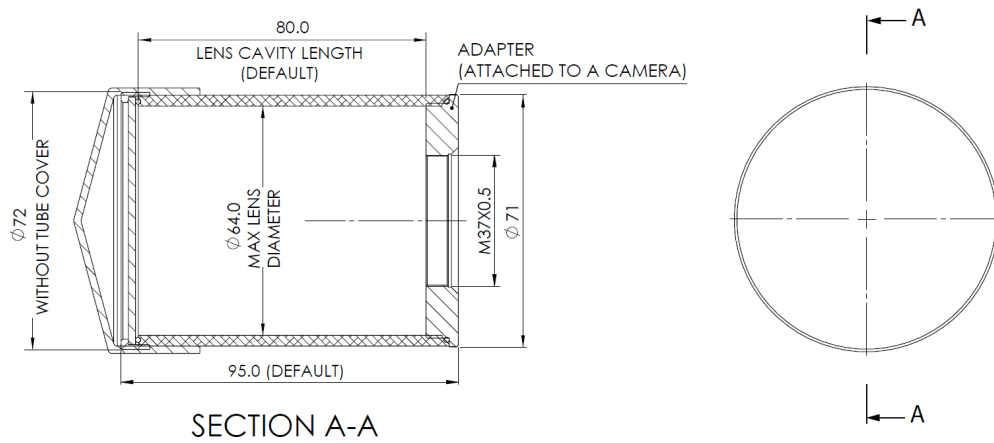

Part Number	Inner Length	Inner Diameter	Outer Diameter	Glass	Housing Material
Tube-64MM-0080 (default)*	80 mm	Ø 64 mm	Ø 70 mm	Clear Glass, Ø 69 mm x 2 mm with oleophobic coating	Aluminum

*Custom Tube Lengths are available, please contact your local distributor or Imperx sales +1-561-989-0006 or sales@imperx.com.

IP67 Lens Tube Extension Kit

The ASSY-44MM-0000 extension kit is used to change the Imperx IP67 lens tube length to fit varying C-mount lens sizes. The ASSY-44MM-0000 extension kit is currently available for the 44-mm tubes only.

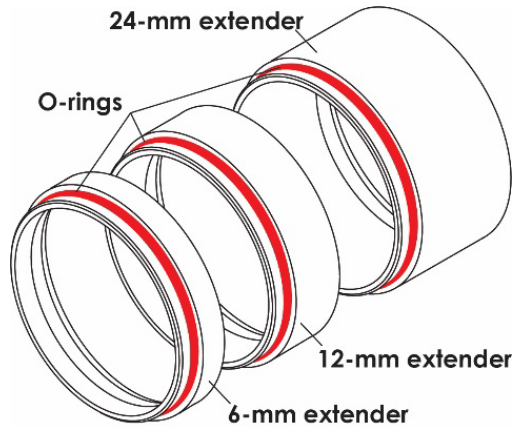

Part Number	Inner Length	Qty.	Inner Diameter	Outer Diameter	Glass	Material
ASSY-44MM-0000 includes:						
6-mm extender with O-ring	6 mm	1	Ø 44 mm	Ø 50 mm	N/A	Aluminum
12-mm extender with O-ring	12 mm	1	Ø 44 mm	Ø 50 mm	N/A	Aluminum
24-mm extender with O-ring	24 mm	1	Ø 44 mm	Ø 50 mm	N/A	Aluminum
Extra O-ring Ø 45 mm x 1 mm	N/A	2	N/A			Silicone

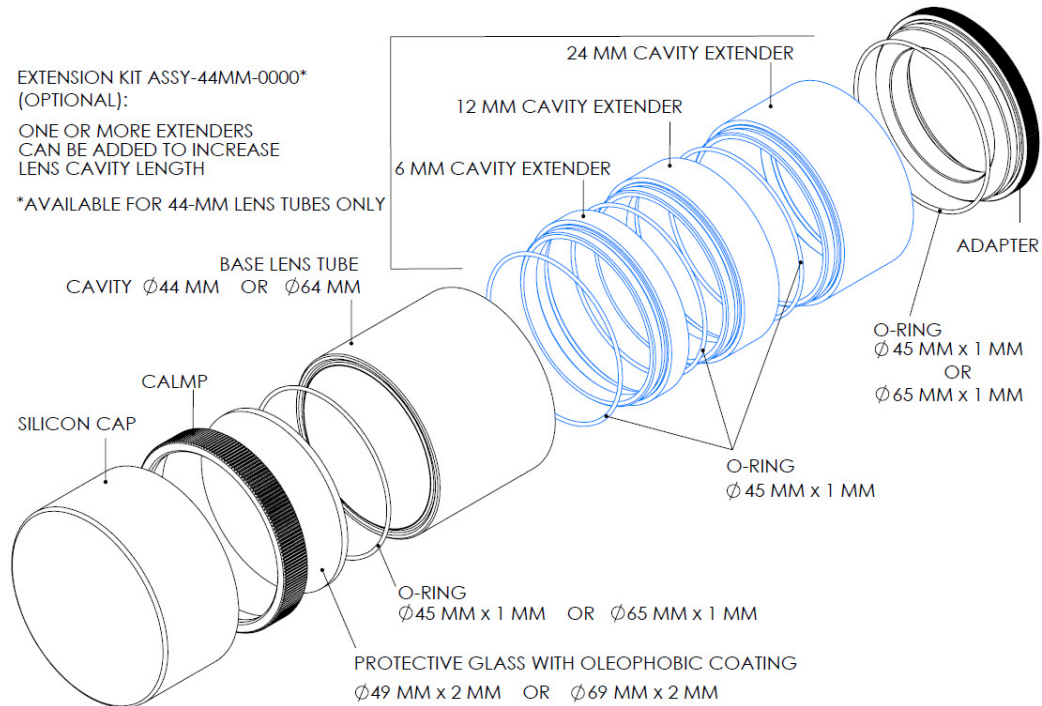

P67 Camera Handling Instructions

CAUTION

Do not remove the protective glass on the lens tube! If the glass is fastened improperly, the camera loses its IP67 rating.

To mount or adjust a mounted lens, detach the lens tube from the adapter. Be sure to attach a lens or dust cap to the camera immediately upon removing the lens tube. This protects the image sensor from dust and dirt.

Do not over-tighten the lens tube and extender! Over-tightening may deform the thread or O-ring and cause the lens tube to become stuck on the adapter.

Do not under-tighten the lens tube and extender! Otherwise, water infiltration is possible.

To protect the image sensor from dust and dirt, attach a lens or dust cap to the camera immediately upon removing the lens tube.

P67-C1911, P67-C2010, P67-C2410, P67-C3210, P67-C4010, P67-C4110 cameras mounting plate

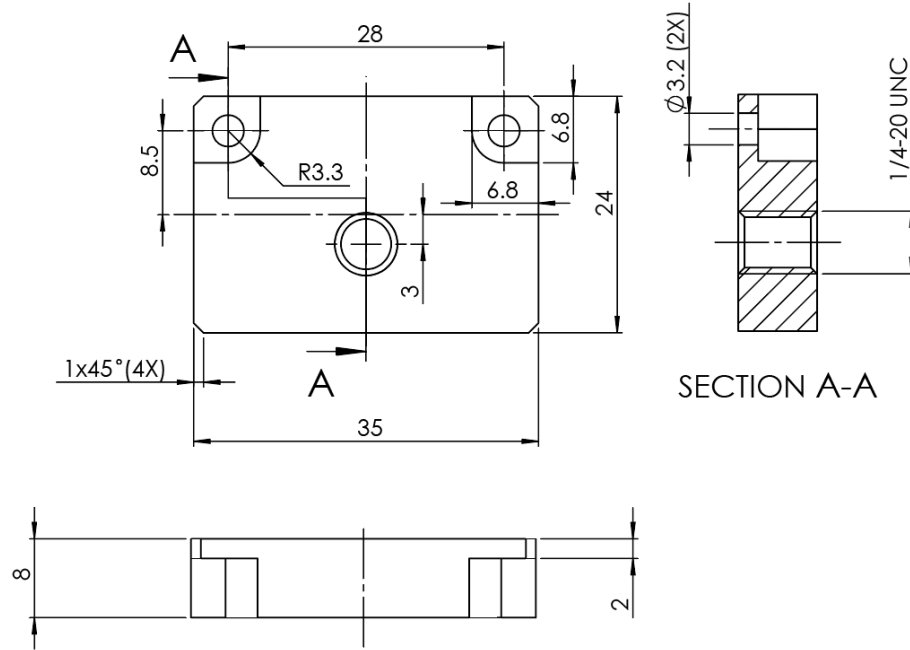

Optical

The Cheetah cameras come with varying adapters for C-mount or F-mount lenses that have different back focal distances. You can use an F-mount lens with a C-mount camera using an F-mount-to-C-mount adapter (with POE-C1911, POE-C2010, POE-C2410, POE-C3210, POE-C4010, and POE-C4110 cameras only). You can purchase the adapter separately (refer to the Imperx web site www.imperx.com for more information).

Camera model	Lens Mount (default)	Back focal distance
POE-C2000, POE-C2400	C-Mount	18.13 mm
POE-C1911, POE-C2010, POE-C2410, POE-C2410Y/Z, POE-C3210, POE-C4010, POE-C4110	C-Mount	17.53 mm
P67-C1911, P67-C2010, P67-C2410, P67-C3210, P67-C4010, P67-C4110	C-Mount	17.53 mm
POE-C4410, POE-C5410, POE-C6410 POE-C4410-T, POE-C5410-T, POE-C6410-T	F-Mount	46.50 mm

The camera is highly sensitive in the infrared (IR) spectral region. All color cameras have an IR cut-off filter installed. Monochrome cameras do not have any optical filter. If necessary, the monochrome camera can accommodate an IR filter (1 mm thickness or less) inserted under the front lens bezel.

CAUTION

Avoid direct exposure to a high intensity light source (such as a laser beam). This may damage the camera image sensor!

Avoid foreign particles on the surface of the image sensor.

Avoid touching the image sensor. Finger oils can produce stains on the sensor decreasing image quality. If the image sensor needs cleaning use soft lint free cloth and an optical cleaning fluid.

Do not use methylated alcohol!

Please refer to the Sensor Cleaning Procedure document found in the camera's ZIP archive or contact Imperx support for cleaning procedures.

TIP

Camera performance and signal to noise ratio (SNR) depend on the illumination (amount of light) reaching the sensor and the exposure time. Always try to balance these two factors. Unnecessarily long exposures increase the amount of dark noise and thus decrease the signal to noise ratio.

Environmental

Always operate the camera within temperature and humidity specifications listed below.

Specification	Definition	Camera
Operating temperature	-30 °C to +75 °C	C1911, C2010, C2410, C3210, C4010, C4110, C4410, C5410, C6410
	-30 °C to +70 °C	C2000, C2400, C4410-T, C5410-T, and C6410-T
Storage temperature	-40 °C to + 85 °C	all camera models
Relative humidity	10% to 90%	all camera models

CAUTION

For all cameras, except P67, avoid direct exposure to moisture and liquids. The camera housing is not hermetically sealed, and any exposure to liquids may damage the camera electronics!

Avoid operating in an environment without any air circulation, near an intensive heat source, strong magnetic or electric fields.

For P67 cameras to maintain IP67 rating and warranty, sealing caps MUST present when camera's connectors are not mated.

Do not submerge the P67 camera or subject it to a direct water spray or dust without the lens tube and IP67-rated cables (or sealing caps) attached! The IP67 cables (or sealing caps) and lens tube prevent water or dust from entering the camera and damaging it.

Do not remove the protective glass on the P67 camera's lens tube! If the glass is fastened improperly, the camera loses its IP67 rating.

NOTE

The P67 camera's O-rings are made from silicone and can degrade when exposed to chemicals; especially, petroleum oils, fuels and acids. Please check with O-ring manufacturer, SEAL & DESIGN Inc., <https://www.sealanddesign.com> (Silicon (VMQ) O-rings), if the camera will be exposed to any chemicals other than water.

GenICam™ API Module – Configuring the Camera

Overview

Imperx Cheetah cameras are highly programmable and flexible. They allow control of all the camera's resources. You communicate with the GEV camera from a simple GenICam™ compliant GigE graphical user interface (GUI). The GUI is bi-directional allowing you to issue commands to the camera and allowing the camera to issue responses (either status or information). You can configure and monitor all camera's features and resources.

The Cheetah camera ships with the Imperx Camera SDK software which includes the SDK and IpxPlayer application to control the camera and view/save images. Chapter [Software GUI](#) provides information on Camera SDK software installing, IpxPlayer application interface, and parameter windows.

Camera User Set Description

Startup Procedure

Upon powering up or receiving the *DeviceReset* command, the camera performs the following steps:

1. Boot loader checks program flash memory for a valid firmware image and loads it into the field-programmable gate array (FPGA).
2. The camera reads the Boot From register from the parameter Flash and loads a workspace from one of the configuration spaces determined by the User Set Default Selector. The configuration spaces are: Factory Space (Default), User Space #0, #1, #2 or #3.
3. The camera runs the IP configuration according the GigE Vision standard, obtains the IP address, and is ready for device enumeration by host application.

GenApi Camera Configuration

The camera's XML nodes are listed below with a description of the camera's configuration parameters, interface type, range of control values, and access mode for the parameter (RW: Read/Write, RO: Read Only, WO: Write Only).

While most configuration parameters are supported in all cameras, availability of some parameters may vary between different camera models.

Parameter	Camera model supporting the parameter
<i>Decimation</i>	All models except for POE-C2000 and POE-C2400
<i>Binning</i>	Monochrome only: POE-C1911, P67-C1911, POE-C3210, P67-C3210, POE-C4410, POE-C5410, POE-C6410, POE-C4410-T, POE-C5410-T, POE-C6410-T
<i>Slave AOI</i>	All models except for POE-C2000 and POE-C2400
Line 2 in <i>TriggerSource</i>	POE-C1911, POE-C2010, POE-C2410, POE-C2410Y/Z, POE-C3210, POE-C4010, POE-C4110, POE-C4410, POE-C5410, POE-C6410, POE-C4410-T, POE-C5410-T, and POE-C6410-T
<i>AEC/AGC</i>	All camera models except for POE-C2000 and POE-C2400
<i>IrisAuto</i> and <i>P-Iris Lens Control</i>	POE-C1911, POE-C2010, POE-C2410, POE-C2410Y/Z, POE-C3210, POE-C4010, POE-C4110
<i>OUT2</i> and <i>Strobe2</i>	All camera models except for POE-C2000 and POE-C2400
IN2 in <i>EventSelector</i>	POE-C1911, POE-C2010, POE-C2410, POE-C2410Y/Z, POE-C3210, POE-C4010, POE-C4110, POE-C4410, POE-C5410, POE-C6410, POE-C4410-T, POE-C5410-T, and POE-C6410-T
OUT2 in <i>EventSelector</i>	All camera models except for POE-C2000 and POE-C2400
<i>Canon Lens Control</i>	POE-C4410, POE-C5410, POE-C6410, POE-C4410-T, POE-C5410-T, and POE-C6410-T
<i>Temperature Control</i>	POE-C4410-T, POE-C5410-T, POE-C6410-T

NOTE ⚠ In the following tables, parameter names highlighted in *red italic* letters are changeable only if image acquisition is turned **off**. You cannot change these parameters if image acquisition is on. After making changes, you can turn the camera image acquisition back **on**.

Device Control

Device Control provides read-only information about the camera's XML file and enables camera reset functionality.

Parameter Name	Type	Value	Access	Description	
DeviceSFNCVersionMajor	Integer		RO	Major version of SFNC used for XML.	
DeviceSFNCVersionMinor	Integer		RO	Minor version of SFNC used for XML.	
DeviceSFNCVersionSubMinor	Integer		RO	Sub-minor version of SFNC used for XML.	
DeviceReset	Command		WO	Resets camera to power-up state (resets both the GEV Engine and the camera head).	
CameraHeadReset	Command		WO	Resets the camera circuitry. The GEV Engine doesn't reset. NOTE: After camera reset, issue a <i>UserSetLoad</i> command.	
DeviceTemperatureSelector	Enumeration	String Sensor Mainboard PowerSupplyBoard SensorBoard	Num. 0 1 2 3	RW	Selects the location within the camera where the temperature will be measured. (See a note below.)
DeviceTemperature	Float		RO	Camera temperature in degrees Celsius (C) measured at the location selected by <i>DeviceTemperatureSelector</i> .	

NOTE (*) The image sensor temperature is a rough value and accurate to ± 5 °C tolerance. This feature cannot be used for precise measurements.

Only Cheetah cameras with TEC are calibrated to compensate for the difference. For these cameras, the image sensor temperature value is precise.

Temperature Control

Parameter Name	Type	Value	Access	Description
TECMode	Enumeration	String Off On Auto	Num. RW 0 1 2	Sets the operation mode of the camera's thermoelectric cooling module (TEC).
TargetSensorTemperature	Float	Min: 0 Max: 50	RW	Sets the target temperature in Celsius degrees for TEC.
TECStatus	Enumeration	String In_Range Min_Reached Max_Reached	Num. RO 0 1 2	Returns the camera's Thermo-Electric Cooler unit status.
FanStatus	Enumeration	String Off On	Num. RO 0 1	Returns the camera's fan status.
IMXPowerStatus	Enumeration	String Off On	Num. RO 0 1	Returns image sensor power status. When the temperature of one of the camera's boards reaches 90 °C, the image sensor power turns off. The power restores once the temperatures of all boards have decreased to 75 °C.

Version Information

Version Information provides read-only information identifying the camera's firmware, hardware, software, image sensor, camera version, and so on. This information is programmed during the manufacturing process and stored in non-volatile memory.

Parameter Name	Type	Value	Access	Description	
SensorType	Enumeration	String	Num.	RO	Returns the CMOS sensor type.
		Monochrome	0		
		Bayer	1		
		Polarization_Monochrome	2		
		Polarization_Bayer	4		
SensorModel	Enumeration	String	Num.	RO	Returns the CMOS model name.
		Unknown	0		
		IMX250LQR	0x00FA0000		
		IMX250LLR	0x04FA0000		
		IMX252LQR	0x00FC0000		
		IMX252LLR	0x04FAC000		
		IMX264LQR	0x01080000		
		IMX264LLR	0x05080000		
		IMX265LQR	0x01090000		
		IMX265LLR	0x05090000		
		IMX267LQR	0x010B0000		
		IMX267LLR	0x050B0000		
		IMX304LQR	0x01300000		
		IMX304LLR	0x05300000		
		IMX342LQR	0x01560000		
		IMX342LLR	0x05560000		
		IMX367LQR	0x016F0000		
		IMX367LLR	0x056F0000		
		IMX387LQR	0x01830000		
		IMX387LLR	0x05830000		
		IMX420LQR	0x01A40000		
		IMX420LLR	0x05C40000		
		IMX428LQR	0x01AC0000		
		IMX428LLR	0x05AC0000		
		IMX429LQR	0x01AD0000		
		IMX429LLR	0x05AD0000		
		IMX250MZR	0x06FA0000		
IMX250MYR	0x02FA0000				
RgsID	Integer			RO	Returns RGS ID.
FpgalD	Integer			RO	Returns the FPGA ID (0=EP4C25, 1=EP4C40, 3=5CEFA4, 5=5CEFA5).
EpcsID	Integer			RO	Returns the EPCS ID (0=EPCS16, 1=EPCS64, 2=EPCS128).

Parameter Name	Type	Value	Access	Description
FirmwareImage	Integer		RO	Returns the Firmware Image ID (F=Factory or A=Application).
CameraHeadFirmwareVersion	Integer		RO	Returns the Camera Head Firmware Version Number.
CameraHeadFirmwareBuild	Integer		RO	Returns Firmware build Number.
CustomerID	Integer		RO	Returns Customer ID for custom cameras (0=Imperx Standard camera).
FamilyID	Integer		RO	Returns Camera Family ID.
XMLVersion	Integer		RO	Returns XML Version.
GEVFirmwareSWVersion	Integer		RO	Shows software version of GigE Vision engine firmware.
GevFirmwareHwVersion	Integer		RO	Shows Hardware version for GigE Vision engine firmware.

Image Format Control

Image Format Control lets you change screen resolution, select pixel format, and more.

Parameter Name	Type	Value	Access	Description	
WidthMax	Integer		RO	Returns max. width of image in pixels.	
HeightMax	Integer		RO	Returns max. height of image in pixels.	
<i>Width</i>	Integer	Min: Depends on camera model Max: Depends on camera model	RW	AOI Width: Actual image output width (in pixels), multiple of 32.	
<i>Height</i>	Integer	Min: Depends on camera model Max: Depends on camera model	RW	AOI Height: Actual image output height (in lines), multiple of 8.	
<i>OffsetX</i>	Integer	Min: 0 Max: Depends on Width	RW	AOI Horizontal offset from left side of image (in pixels), multiple of 32.	
<i>OffsetY</i>	Integer	Min: 0 Max: Depends on Height	RW	AOI Vertical offset from the top of the image (in pixels), multiple of 8.	
<i>ConstantFrameRate</i>	Boolean		RW	Enables Constant Frame Rate independent of AOI size.	
<i>PixelFormat</i> ¹	Enumeration	String Mono8 Mono10 Mono10Packed Mono12 Mono12Packed BayerGR8 BayerRG8 BayerGB8 BayerBG8 BayerGR10 BayerRG10 BayerGB10 BayerBG10 BayerGR12 BayerRG12 BayerGB12 BayerBG12 BayerGR10Packed BayerRG10Packed BayerGB10Packed BayerBG10Packed BayerGR12Packed BayerRG12Packed BayerGB12Packed BayerBG12Packed	Num. 0x01080001 0x01100003 0x010C0004 0x01100005 0x010c0006 0x01080008 0x01080009 0x0108000A 0x0108000B 0x0110000C 0x0110000D 0x0110000E 0x0110000F 0x01100010 0x01100011 0x01100012 0x01100013 0x010C0026 0x010C0027 0x010C0028 0x010C0029 0x010C002A 0x010C002B 0x010C002C 0x010C002D	RW	Sets Output Data Pixel format. Color cameras, without image flipping, use BayerRG8, BayerRG10 or BayerRG12, BayerRG10Packed or BayerRG12Packed format.

Parameter Name	Type	Value		Access	Description
PixelSize	Enumeration	String Bpp8 Bpp10 Bpp12	Num. 0 1 2	RO	Number of bits per pixel.
PixelColorFilter	Enumeration	String None BayerRG BayerGB BayerGR BayerBG	Num. 0 1 2 3 4	RO	Type of color filter that is applied to the image.
DecimationVerticalMode ²	Enumeration	String Discard	Num. 0	RO	Returns the mode used to reduce the vertical resolution when <i>DecimationVertical</i> is used.
<i>DecimationVertical</i>	Integer	Min: 1 Max: 2		RW	Vertical sub-sampling of the image. This reduces the vertical resolution (height) of the image by the specified vertical decimation factor.
DecimationHorizontalMode ²	Enumeration	String Discard	Num. 0	RO	Returns the mode used to reduce the horizontal resolution when <i>DecimationHorizontal</i> is used.
<i>DecimationHorizontal</i>	Integer	Min: 1 Max: 2		RW	Horizontal sub-sampling of the image. This reduces the horizontal resolution (width) of the image by the specified horizontal decimation factor.
BinningVerticalMode ³	Enumeration	String Sum	Num. 0	RO	Returns the mode used to combine horizontal photo-sensitive cells together when <i>BinningVertical</i> is used.
<i>BinningVertical</i>	Integer	Min: 1 Max: 2		RW	Number of vertical photo-sensitive cells to combine together. This reduces the vertical resolution (height) of the image.
BinningHorizontalMode ³	Enumeration	String Sum	Num. 0	RO	Returns the mode used to combine horizontal photo-sensitive cells together when <i>BinningHorizontal</i> is used.

Parameter Name	Type	Value	Access	Description
<i>BinningHorizontal</i>	Integer	Min: 1 Max: 2	RW	Number of horizontal photo-sensitive cells to combine together. This reduces the horizontal resolution (width) of the image.
Polarization ⁴	Enumeration	String Off Filter_90_degrees Filter_45_degrees Filter_135_degrees Filter_0_degrees	Num. 0 1 2 3 4	RW The values of pixels with the selected polarizing filter are kept, others are discarded (supported in C2410Y/Z cameras only).
TestPattern	Enumeration	String Off BwCheckerBoard Grey TapSegmented GreyHorizontalRamp GreyVerticalRamp HorizontalAndVerticalRamp HorizontalAndVerticalRampMoving VerticalBars Crosshair IpxGevPattern	Num. 0 1 2 3 4 5 6 7 8 9 16	RW Selects type of test pattern generated by device replacing image source (refer to section Test Image Pattern for more information).

¹For color cameras, set *PixelFormat* to a desired value (BayerRG is a default format) and then enable *ReverseX* and/or *ReverseY* features:

Original *PixelFormat*: BayerRG8
ReverseX and *ReverseY* are disabled

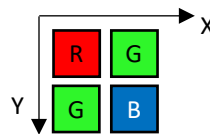

ReverseX is enabled
 New *PixelFormat*: BayerGR8



ReverseY is enabled
 New *PixelFormat*: BayerGB8



ReverseX and *ReverseY* are enabled together
 New *PixelFormat*: BayerBG8



²**DecimationVertical/Horizontal Modes value:**

Discard methods

DecimationVertical: Every other row is discarded.

DecimationHorizontal: Within a row, the value of every other pixel is kept, others are discarded.

NOTE (*) Currently, the camera performs the **Discard** mode only.

To enable decimation feature, set *DecimationHorizontal* or *DecimationVertical* to 2. Setting the value to 1 disables decimation.

The decimation is inactive when *BinningVertical* or *BinningHorizontal* is enabled, and vice versa.

³**BinningHorizontal/Vertical Mode value:**

Sum: The response from the combined cells is added, resulting in increased sensitivity.

NOTE (*) Currently, the camera performs **Summation** mode only.

To enable binning feature, set *BinningHorizontal* or *BinningVertical* to 2. Setting the value to 1 disables binning.

The binning is inactive when *DecimationVertical* or *DecimationHorizontal* is enabled, and vice versa.

⁴**Polarization values:**

Off: the values of each pixel are output. The output image has a resolution of 2464 (H) x 2056 (V) pixels.

Filter_90_degrees, Filter_45_degrees, Filter_135_degrees, Filter_0_degrees: the output image consists of pixels with selected polarization angle, other pixels are discarded. This reduces the vertical and horizontal resolution of the image by 2. The output image has a resolution of 1232 (H) x 1028 (V) pixels.

In the example below, a polarization angle of 90° is selected, and the resulting image consists of the pixels framed in red.

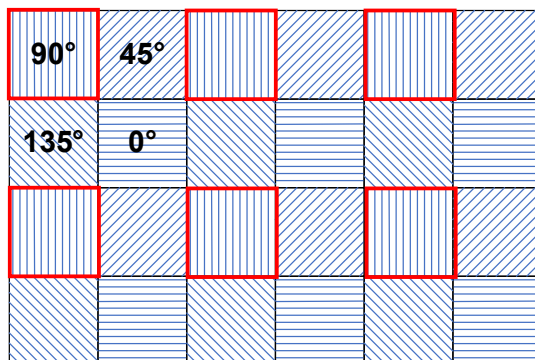

Slave AOI

Slave AOI is supported by all cameras except for POE-C2000 and POE-C2400.

Parameter Name	Type	Value	Access	Description	
<i>SAOI_Width</i>	Integer	Min: Depends on camera model Max: Depends on camera model	RW	Actual image width of the Slave AOI (in pixels). The number must be a multiple of 32.	
<i>SAOI_Height</i>	Integer	Min: Depends on camera model Max: Depends on camera model	RW	Actual image height of the Slave AOI (in pixels). The number must be a multiple of 8.	
<i>SAOI_OffsetX</i>	Integer	Min: Depends on camera model Max: Depends on camera model	RW	Horizontal offset from the beginning of each row to the Slave AOI (in pixels). The number must be a multiple of 32.	
<i>SAOI_OffsetY</i>	Integer	Min: Depends on camera model Max: Depends on camera model	RW	Vertical offset from the top of the image to the Slave AOI (in pixels). The number must be a multiple of 8.	
SAOI_Mode	Enumeration	String Disable Include Exclude AEC_AGC_Include AEC_AGC_Exclude AWB_Include AWB_Exclude LUT_Include LUT_Exclude	Num. 0 1 2 3 4 5 6 7 8	RW	Sets Slave AOI mode. The Slave AOI might be used as AOI for AGC/AEC, AWB and LUT (refer to Slave AOI for more information).

Acquisition Control

Acquisition Control lets you configure settings for image capture, exposure, frame rates, triggers, and so on. It also provides read-only information on frame and exposure time.

Parameter Name	Type	Value	Access	Description
AcquisitionMode	Enumeration	String SingleFrame MultiFrame Continuous	Num. RW 0 1 2	Defines the number of frames to capture during acquisition and the way the acquisition stops.
AcquisitionStart	Command		WO	Starts device acquisition.
AcquisitionStop	Command		WO	Stops acquisition after current frame completes readout.
AcquisitionAbort	Command		WO	Stops acquisition immediately, but a partially transferred image will be completed.
<i>AcquisitionFrameCount</i>	Integer	Min: 1 Max: 65535	RW	Number of Frames to acquire in the Multi-Frame Acquisition mode.
ExposureMode	Enumeration	String Off TriggerWidth Timed	Num. RW 0 1 2	Sets exposure mode. Off: exposure time equals frame time (refer to Exposure Control for more information).
ExposureTime	Float		RW	Sets Timed Exposure in micro-seconds when <i>ExposureMode</i> is Timed and <i>ExposureAuto</i> is Off.
AcquisitionFrameRateEnable	Boolean		RW	Controls if the <i>AcquisitionFrameRate</i> and <i>AcquisitionFrameTime</i> features are writable and used to control the acquisition rate. If On, you can extend the actual frame time beyond the free-running frame time. Trigger is disabled and cannot be used in combination with this feature.
AcquisitionFrameTime	Integer	Min: Depends on camera model Max: 16777215	RW	Sets Frame Time in microseconds. 16 seconds maximum.

Parameter Name	Type	Value	Access	Description	
AcquisitionFrameRate	Float		RW	Controls acquisition rate (in Hz) of frames captured.	
CurrentExposureTime	Integer		RO	Returns current exposure time in microseconds.	
CurrentFrameTime	Integer		RO	Returns current frame time in microseconds.	
CurrentFrameReadOutTimeLines	Integer		RO	Returns the current frame readout time in units of sensor lines	
CurrentLineTimePClocks	Integer		RO	Returns the current line time in units of sensor clock cycle. Sensor clock is equal to 37.125 MHz.	
CurrentLineTimeUSeconds	Integer		RO	Returns the current line time in microseconds.	
<i>TriggerMode</i>	Enumeration	String Off On	Num. 0 1	RW	Enables Trigger mode of operation. Not available if <i>AcquisitionFrameRateEnable</i> parameter is On.
TriggerSoftware	Command			WO	Generates internal trigger. <i>TriggerSource</i> must be set to Software.
TriggerSource	Enumeration	String Line1 Line2 PulseGenerator Software	Num. 1 5 2 4	RW	Specifies internal signal or external Line as trigger source. <i>TriggerMode</i> must be set to On (refer to Trigger Sources for more information).
TriggerActivation	Enumeration	String RisingEdge FallingEdge	Num. 0 1	RW	Specifies activation edge of trigger.
TriggerDebounceTime	Integer	Min: 0 Max: 65535		RW	Specifies time period (in microseconds) when a second trigger is not accepted.
TriggerOverlap	Enumeration	String Off	Num. 0	RO	Specifies the trigger overlap mode, if the camera receives a trigger pulse while the camera is still processing the previous trigger.

Parameter Name	Type	Value	Access	Description
TriggerType	Enumeration	String Standard Fast	Num. 0 1 RW	Standard: Exposure and readout are sequential. Fast: Exposure and readout overlapped.
<i>TriggerNumFrames</i>	Integer	Min: 1 Max: 65531	RW	Number of frames captured per trigger. Available only in Standard trigger mode with <i>ExposureMode</i> set to Timed.
TriggerDelay	Integer	Min: 0 Max: 1000000	RW	Specifies delay between Trigger to start of exposure (in microseconds).

Gain Control

Gain Control provides parameters for setting analog/digital gain and black level.

Parameter Name	Type	Value	Access	Description
Gain	Float	Min: 0.0 Max: 48.0	RW	Sets analog/digital gain in dB. Increment is 0.1 dB.
BlackLevelAuto	Enumeration	String Off Continuous	Num. 0 1 RW	Sets the mode for Auto-Black Level Adjustment.
BlackLevel	Float	Min: 0 Max: 4095	RW	Controls the analog black level as an absolute physical value. Adds a fixed analog offset to the video level.
DigitalGain	Float	Min: 1.00 Max: 4.00	RW	The pixel value is multiplied by the Digital Gain Factor. Increment is 0.01.
DigitalGainRaw	Integer	Min: 1024 Max: 4095	RW	Controls the raw value of <i>DigitalGain</i> from 1024 (1x) to 4095 (4x) in steps of 0.001x (Refer to section Digital Gain for more information on determining raw values).
DigitalOffset	Integer	Min: -512 Max: 511	RW	Adds a digital offset (+ or -) to the video data.
DigitalOffsetRaw	Integer	Min: 0 Max: 1023	RW	Controls the Digital Offset in RAW units.

Auto Exposure, Auto Gain, and Auto Iris Control (AEC/AGC/AIC)

You can set the camera to automatic exposure, gain, or iris control (AEC/AGC/AIC) to keep the same image brightness during changing light conditions. You can enable AEC, AGC, and AIC independently or together. Auto gain, auto exposure, and auto iris controls let you control the range of exposure times, gain values, and iris positions used by placing minimum and maximum limits on these parameters.

NOTE ✳ Auto Exposure and Auto Gain Control are supported in all cameras except for POE-C2000 and POE-C2400.

Auto Iris Control is supported in the POE-C1911, POE-C2010, POE-C2410, POE-C3210, POE-C4010, and POE-C4110 cameras only.

Control

Parameter Name	Type	Value		Access	Description
GainAuto	Enumeration	String Off Continuous	Num. 0 1	RW	Enables automatic gain control (AGC) mode.
AgcGainMin	Float	Min: 0 Max: AgcGainMax		RW	Sets the minimum gain applied (in dB) when AGC is enabled. Increment is 0.1 dB.
AgcGainMinRaw	Integer	Min: 0 Max: AgcGainMax		RW	Sets the minimum Digital Gain value for the AGC mode in RAW units.
AgcGainMax	Float	Min: AgcGainMin Max: 48.000		RW	Sets the maximum gain applied (in dB) when AGC is enabled. Increment is 0.1 dB.
AgcGainMaxRaw	Integer	Min: AgcGainMinReg Max: 480		RW	Sets the maximum Digital Gain value for the AGC mode in RAW units.
ExposureAuto	Enumeration	String Off Continuous	Num. 0 1	RW	Enables automatic exposure control (AEC) mode. If <i>ExposureMode</i> is <i>TriggerWidth</i> , the AEC is inactive. If enabled, the <i>ExposureMode</i> automatically sets to <i>Timed</i> and turns inactive.

Parameter Name	Type	Value	Access	Description	
AecExposureMin	Integer	Min: MinExposureTime Max: AecExposureMax	RW	Sets min. exposure time value for AEC in microseconds.	
AecExposureMax	Integer	Min: AecExposureMin Max: IntExposureMax	RW	Sets max. exposure time value for AEC in microseconds.	
IrisAuto	Enumeration	String Off Continuous	Num 0 1	RW	Sets the automatic iris control (AIC) mode
AicIrisMin	Integer	Min: 0 Max: AicIrisMax	RW	Sets the Minimum Iris position for the AIC in steps.	
AicIrisMax	Integer	Min: AicIrisMinReg Max: PIrisMaxValue	RW	Sets the Maximum Iris position for the AIC in steps.	
AgcAecAicLuminanceLevel	Integer	Min: 1 Max: 4095	RW	Sets target luminance level for AGC/AEC/AIC up to 4095 counts.	
AgcAecAicLuminanceType	Enumeration	String Average Peak	Num. 0 1	RW	Sets how the luminance level in the scene is determined.
AgcAecAicSpeed	Enumeration	String x1 x2 x3 x4	Num. 0 1 2 3	RW	Sets AEC/AGC/AIC tracking speed. 4x is fastest, 1x is slowest.

Status

Parameter Name	Type	Value	Access	Description
AgcGainCurrentValue	Float	Min: 0.0 Max: 48.0	RO	Reports current value of gain in AGC mode in dB.
AgcGainCurrentValueRaw	Integer	Min: 0 Max: 480	RO	Reports current value of gain in AGC mode in RAW units.
AgcMinLimitReached	Integer		RO	Returns whether or not the minimum gain limit was reached during AGC operation.
AgcMaxLimitReached	Integer		RO	Returns whether or not the maximum gain limit was reached during AGC operation.
AecExposureCurrentValue	Integer		RO	Reports current value of exposure in microseconds in AEC mode.

Parameter Name	Type	Value	Access	Description
AecMinLimitReached	Integer		RO	Returns whether or not the minimum exposure limit was reached during AEC operation.
AecMaxLimitReached	Integer		RO	Returns whether or not the maximum exposure limit was reached during AEC operation.
AicIrisCurrentValue	Integer		RO	Displays the current position of Iris in steps.
AicMinLimitReached	Integer		RO	Returns whether or not the minimum iris limit was reached during AIC operation.
AicMaxLimitReached	Integer		RO	Returns whether or not the maximum iris limit was reached during AIC operation.
CurrentAvgOrPeakLuminance	Integer		RO	Returns current average or peak luminance in counts.
AgcAecAicStatus	Integer		RO	Displays the value of AgcAecStatus register.

Data Correction

Data Correction parameters enable you to implement look-up tables and other techniques to improve image sensor performance.

Parameter Name	Type	Value	Access	Description
LUTEnable	Enumeration	String	Num. RW	Selects and enables LUT to be used in processing image. (LUT1 and LUT3 are preprogrammed with Gamma 0.45, LUT 2 and LUT 4 – with negative LUT)
		Off	0	
		LUT1	1	
		LUT2	2	
		LUT3	3	
FFCEnable	Enumeration	String	Num. RW	Selects FFC to be used in processing image.
		Off	0	
		FFC1	1	
BadPixelCorrection	Enumeration	String	Num. RW	Enables bad pixel correction. You can upload your own bad pixel map.
		Off	0	
		Factory	1	
User			4	
NegativeImage	Boolean		RW	Inverts the image from positive to negative.

Parameter Name	Type	Value	Access	Description
ReverseX	Boolean		RW	Horizontally flips the image output. The AOI is applied after the flipping. On color cameras, make sure to change PixelFormat before enabling <i>ReverseX</i> feature.
ReverseY	Boolean		RW	Vertically flips the image sent by the camera. The AOI is applied after the flipping. On color cameras, make sure to change PixelFormat when enabling <i>ReverseY</i> feature.
BitShift	Enumeration	String NoShift OneBitRight TwoBitsRight ThreeBitsRight FourBitsRight FiveBitsRight SixBitsRight SevenBitsRight OneBitLeft TwoBitsLeft ThreeBitsLeft FourBitsLeft FiveBitsLeft SixBitsLeft SevenBitsLeft	Num. RW 0 1 2 3 4 5 6 7 9 10 11 12 13 14 15	Shifts the data output bits left or right.

White Balance

White Balance parameters give you control over the individual red, green, and blue colors produced by the sensor in color cameras.

Parameter Name	Type	Value	Access	Description
BalanceWhiteAuto	Enumeration	String Off Once Continuous Manual	Num. 0 1 2 3	RW Controls the camera white balance. Options 1 and 2 calculate color coefficients automatically (see section Color Control).
RedCoefficient	Integer	Min: 0 Max: 4095	RW	Manually sets white balance coefficient for red channel.
GreenCoefficient	Integer	Min: 0 Max: 4095	RW	Manually sets white balance coefficient for green channel.
BlueCoefficient	Integer	Min: 0 Max: 4095	RW	Manually sets adjusted white balance coefficient for blue channel.
RedCoefficientAuto	Integer		RO	Displays the white balance coefficient for the Red channel (when <i>BalanceWhiteAuto</i> is Once or Continuous).
GreenCoefficientAuto	Integer		RO	Displays the white balance coefficient for the Green channel (when <i>BalanceWhiteAuto</i> is Once or Continuous).
BlueCoefficientAuto	Integer		RO	Displays the white balance coefficient for the Blue channel (when <i>BalanceWhiteAuto</i> is Once or Continuous).

Output and Strobe Signals

OUT2 and Strobe2 parameters are supported by all cameras except for POE-C2000 and POE-C2400 cameras.

OUT1 Parameters

Parameter Name	Type	Value		Access	Description
OUT1Polarity	Enumeration	String	Num.	RW	Sets active logic level of OUT1 output.
		ActiveLow	0		
		ActiveHigh	1		
OUT1Selector	Enumeration	String	Num.	RW	Maps various internal signals to OUT1 output (refer to the section Strobe and Synchronization Controls for more information on output signals).
		None	0		
		ExposureStart	1		
		ExposureEnd	2		
		MidExposure	3		
		ExposureActive	4		
		HSync	5		
		VSync	6		
		OddEvenFrame	7		
		TriggerActual	8		
		TriggerDelayed	9		
		CameraRead	10		
		PulseGenerator	11		
		Strobe1	12		
Strobe2	13				
ToggleOut1	14				

OUT2 Parameters

Parameter Name	Type	Value		Access	Description
OUT2Polarity	Enumeration	String	Num.	RW	Sets active logic level of OUT2 output.
		ActiveLow	0		
		ActiveHigh	1		
OUT2Selector	Enumeration	String	Num.	RW	Maps various internal signals to OUT2 output (refer to the section Strobe and Synchronization Controls for more information on output signals).
		None	0		
		ExposureStart	1		
		ExposureEnd	2		
		MidExposure	3		
		ExposureActive	4		
		HSync	5		
		VSync	6		
		OddEvenFrame	7		
		TriggerActual	8		
		TriggerDelayed	9		
		CameraReady	10		
		PulseGenerator	11		
		Strobe1	12		
Strobe2	13				
ToggleOut2	14				

Strobe Parameters

Parameter Name	Type	Value	Access	Description	
Strobe1Mode	Enumeration	String	Num.	RW	Sets the Strobe1 mode of operation.
		Off	0		
		EachFrame	1		
		OddFrame	2		
		EvenFrame	3		
Strobe1Width	Integer	Min: 1 Max: Depends on CurrentFrameTime and Strobe1Delay	RW	Sets Strobe1 pulse duration in microseconds.	
Strobe1Delay	Integer	Min: 10 Max: Depends on CurrentFrameTime and Strobe1Width	RW	Sets Strobe1 delay from the reference, in microseconds.	
Strobe2Mode	Enumeration	String	Num.	RW	Sets the Strobe2 mode of operation.
		Off	0		
		EachFrame	1		
		OddFrame	2		
		EvenFrame	3		
Strobe2Width	Integer	Min: 1 Max: Depends on CurrentFrameTime and Strobe2Delay	RW	Sets Strobe2 pulse duration in microseconds.	
Strobe2Delay	Integer	Min: 10 Max: Depends on CurrentFrameTime and Strobe2Width	RW	Sets Strobe2 delay from the reference, in microseconds.	

Pulse Generator

The camera provides an internal pulse generator for generating a trigger signal. You can program it to generate a discrete sequence or a continuous trail of pulse signals.

Parameter Name	Type	Value	Access	Description	
PulseGenGranularity	Enumeration	String	Num.	RW	Sets the multiplication factors of the Pulse Generator where $x1 = 1 \mu\text{S}$, $x10 = 10 \mu\text{S}$, etc.
		x1uS	0		
		x10uS	1		
		x100uS	2		
		x1000uS	3		
PulseGenWidth	Integer		RW	Sets pulse width of Pulse Generator where each unit is equal to <i>PulseGenGranularity</i> .	
PulseGenPeriod	Integer		RW	Sets pulse period of Pulse Generator where each unit is equal to <i>PulseGenGranularity</i> .	

Parameter Name	Type	Value	Access	Description
PulseGenNumPulses	Integer	Min: 1 Max: 65535	RW	Sets number of pulses to be generated by Pulse Generator. To set Pulse Generator in continuous mode, set the parameter in 65536
PulseGenEnable	Boolean		RW	Enables Pulse Generator.

Canon Lens Control

Canon EF Lens supports motorized iris and focus (not zoom). Canon Lens Control parameters give you control over iris and focus position and are available in POE-C4410, POE-C5410, POE-C6410, POE-C4410-T, POE-C5410-T, and POE-C6410-T cameras. Refer to section [Canon Lens Control](#) for more information on lens adjusting procedures.

Controller Settings

Parameter Name	Type	Value	Access	Description	
InitLens	Command		WO	Initializes the Canon Lens. Always initialize lens after power-up.	
StopLens	Command		WO	Removes power from the Iris drive. Run the <i>InitLens</i> command to resume the lens control.	
LensControllerStatus	Enumeration	String InitLens_Failed InitLens_Done	Num. 0 1	RO	Shows status of Canon Lens initialization.
LensAF_MF	Enumeration	String AutoFocus ManualFocus	Num. 0 1	RO	Shows status of Auto/Manual focus switch located on the lens.
GetLensID	Command		WO	Requests value of Lens ID register.	
LensID	Integer		RO	Returns Lens ID after <i>GetLensID</i> is issued.	

Focus

Parameter Name	Type	Value	Access	Description
NearFull	Command		WO	Drives the focus to the fully Near position.
FarFull	Command		WO	Drives the focus to the fully Far position.
FocusSetupValue	Integer	Min: 1 Max: 255	RW	Sets the focus step to be moved with <i>NearStep</i> and <i>FarStep</i> commands.
NearStep	Command		WO	Drives the focus to the Near direction by the amount defined in the <i>FocusStepValue</i> feature.
FarStep	Command		WO	Drives the focus to the Far direction by the amount defined in the <i>FocusStepValue</i> feature.
FocusReqPosition	Integer	Min: 0 Max: FocusMaxReg	RW	Sets the desired focus value to use with the <i>SetFocusPosition</i> command.
SetFocusPosition	Command		WO	Drives the focus to the absolute position defined in the <i>FocusReqPosition</i> feature.
FocusMax	Integer		RO	Returns maximum focus encoder value.
FocusSetMax	Command		WO	Sets the Focus Max Register with current <i>FocusMax</i> value.
FocusEncoderStatus	Integer		RO	Returns the current focus encoder value after the <i>GetFocusEncoderStatus</i> command is issued.
GetFocusEncoderStatus	Command		WO	Requests the focus encoder position value.
ResetFocusEncoder	Command		WO	Resets the Focus encoder.

Iris

Parameter Name	Type	Value	Access	Description
IrisRequestedPositionRaw	Integer	Min: IrisMin2 Max: IrisMax	RW	Sets raw iris absolute position.
SetIrisPosition	Command		WO	Drives the iris to the absolute position value of <i>IrisRequestedPositionRaw</i> .
CurrentFNumber	Float		RO	Returns the current f-number value of the lens iris. Value of 0.0 signals an unknown iris position.
OpenIrisFull	Command		WO	Opens the iris to the fully opened position.
CloseIrisStep	Command		WO	Closes the iris by the amount defined in the <i>IrisStepValue</i> feature.
OpenIrisStep	Command		WO	Opens the iris by the amount defined in the <i>IrisStepValue</i> feature.
IrisStepValue	Integer	Min: 1 Max: 127	RW	Sets the iris step to be moved with <i>OpenStep</i> and <i>CloseStep</i> commands.
GetIrisRange	Command		WO	Sends the <i>GetIrisRange</i> command to the camera.
IrisMin	Integer		RO	Returns the minimum iris limit.
IrisMax	Integer		RO	Returns the maximum iris limit.
IrisRange	Integer		RO	Displays the Limit values of the iris, after the <i>GetIrisRange</i> command is issued.

P-Iris Lens Control

A P-Iris Lens supports motorized iris. P-Iris Lens Control parameters give you control over iris position and are available in POE-C1911, POE-C2010, POE-C2410, POE-C3210, POE-C4010, and POE-C4110 cameras.

Parameter Name	Type	Value	Access	Description
PirisStepValue	Integer	Min: 1 Max: Depends on PirisMax	RW	Sets the iris step to be moved with <i>OpenPirisStep</i> and <i>ClosePirisStep</i> commands.
PirisMax ¹	Integer	Min: 15 Max: 127	RW	Sets the P-Iris maximum number of steps available. This value is unique for each model of lens.
InitialPirisPosition	Integer	Min: 0 Max: Depends on PirisMax	RW	Sets the P-Iris initial position in number of steps. Equals 0 by default (iris is fully open). To save a new value, use <i>UserSetControl</i> .
CurrentPirisPosition	Integer	Min: 0 Max: Depends on PirisMax	RO	Returns the P-Iris current position in number of steps.
OpenPirisStep	Command		WO	Opens the iris by the amount defined in the <i>PirisStepValue</i> feature.
ClosePirisStep	Command		WO	Closes the iris by the amount defined in the <i>PirisStepValue</i> feature.
OpenPirisFull	Command		WO	Opens the iris to the fully opened position.
ClosePirisFull	Command		WO	Closes the iris to the fully closed position.

¹**PirisMax:** In Default (Factory) configuration, the maximum number of steps is set to 73 (for the Kowa LM25JC5MM lens). The value depends on the lens model and manufacturer and may differ from the default one. Please refer to the documentation on your P-IRIS lens for this parameter or contact a lens distributor for more information.

Transport Layer Information

The Transport Layer control provides a variety of configuration settings and read-only information for configuring communications between the camera with the GigE Vision interface.

Parameter Name	Type	Value	Access	Description
PayloadSize	Integer		RO	<i>PayloadSize</i> provides the number of bytes transferred for each image on the stream channel, including any end-of-line, end-of-frame statistics or other stamp data.

GigE Vision

Parameter Name	Type	Value	Access	Description	
GevMACAddress	Integer		RO	Stores MAC address of network interface.	
<i>GevGVSPExtendedIDMode</i>	Enumeration	String Off On	Num. 0 1	RW	Sets the extended ID mode for GVSP (64 bit block_id64, 32 bit packet_id32). This bit cannot be reset if the stream channels do not support the standard ID mode.
GevCurrentIPConfigurationLLA	Boolean			RW	Indicates if Link Local Address IP configuration scheme is activated on network interface.
GevCurrentIPConfigurationDHCP	Boolean			RW	Indicates if DHCP IP configuration scheme is activated on network interface.
GevCurrentIPConfigurationPersistentIP	Boolean			RW	Indicates if PersistentIP configuration scheme is activated on network interface.
GevCurrentIPAddress	Integer			RO	Reports IP address of network interface after configuring it.
GevCurrentSubnetMask	Integer			RO	Provides subnet mask of network interface.

Parameter Name	Type	Value	Access	Description	
GevCurrentDefaultGateway	Integer		RO	Indicates default gateway IP address to use on network interface.	
GevPersistentIPAddress	Integer		RW	Indicates Persistent IP address of network interface.	
GevPersistentSubnetMask	Integer		RW	Indicates Persistent subnet mask associated with Persistent IP address on network interface.	
GevPersistentDefaultGateway	Integer		RW	Indicates Persistent gateway IP address to use on network interface.	
GevLinkSpeed	Integer		RO	Indicates the speed of transmission negotiated by network interface in Mbps.	
GevCCP	Enumeration	String OpenAccess ExclusiveAccess ControlAccess	Num. 0 1 2	RW	Grants privilege to an application.
GevPrimaryApplicationSocket	Integer		RO	Indicates the UDP source port of the primary application.	
GevPrimaryApplicationIPAddress	Integer		RO	Indicates the address of the primary application.	
GevMCPHostPort	Integer		RW	Controls the port to which the camera must send messages. Setting this value to 0 closes the message channel.	
GevMCDA	Integer		RW	Controls the destination IP address for the message channel.	
GevMCTT	Integer		RW	Provides the message channel transmission timeout value in milliseconds.	

Parameter Name	Type	Value	Access	Description
GevMCRC	Integer		RW	Controls the number of retransmissions allowed when a message channel message times out.
GevMCSP	Integer		RO	This feature indicates the source port for the message channel.
GevSCCFGUnconditionalStreaming	Boolean		RW	Enables the camera to continue to stream, for this stream channel, if its control channel is closed or regardless of the reception of any ICMP messages (such as destination unreachable messages).
GevSCPHostPort	Integer		RW	Indicates the port to which the device must send data stream.
<i>GevSCPSFireTestPacket</i>	Command		RW	When this bit is set, the device will fire one test packet.
<i>GevSCPSDoNotFragment</i>	Boolean		RW	This bit is copied into the Do Not Fragment bit of IP header of each stream packet.
GevSCPD	Integer		RW	Indicates the delay (in timestamp counter unit) to insert between each packet for this stream channel.
<i>GevSCDA</i>	Integer		RW	Indicates the destination IP address for this stream channel.
<i>GevSCSP</i>	Integer		RO	Indicates the source UDP port address for this stream channel.
<i>GevSCFTD</i>	Integer	Min: 0 Max: GevSCFTDMax	RW	Sets a frame transmission delay in microseconds to sequence multiple camera outputs on network. The value of delay between the

Parameter Name	Type	Value	Access	Description
				frame acquisition and transmission.
<i>GevSCPSPacketSize</i>	Integer	Min: 72 Max: 7168	RW	The stream packet size to send on this channel, except for data leader and data trailer; and the last data packet which might be of smaller size (since packet size is not necessarily a multiple of block size for stream channel).
GevHeartbeatTimeout	Integer	Min: 500 Max: 4294967295	RW	This feature indicates the current heartbeat timeout in milliseconds.
GevTimestampTickFrequency	Integer		RO	This 64-bit feature indicates the number of timestamp ticks during 1 second.
GevTimestampControlLatch	Command		WO	Latch current timestamp counter into Timestamp Value register.
GevTimestampControlReset	Command		WO	Reset timestamp 64-bit counter to 0.
GevTimestampValue	Integer		RO	Reports the latched 64-bit value of the timestamp counter.

User Set Controls

User Set Control allows you to save custom settings and reload them into the camera as needed.

Parameter Name	Type	Value		Access	Description
<i>UserSetSelector</i>	Enumeration	String Default UserSet0 UserSet1 UserSet2 UserSet3	Num. 0 1 2 3 4	RW	Selects User Set to load, save, or configure. Default is defined by the Factory.
<i>UserSetLoad</i>	Command			WO	Loads User Set specified by <i>UserSetSelector</i> from non-volatile memory into camera and makes it active.
<i>UserSetSave</i>	Command			WO	Saves User Set 0 ,1, 2 or 3 specified by <i>UserSetSelector</i> to non-volatile memory.
<i>UserSetDefault</i>	Enumeration	String Default UserSet0 UserSet1 UserSet2 UserSet3	Num. 0 1 2 3 4	RW	Selects User Set to load and activate when device is powered on or reset. Default is set by Factory.

Event Control

Event Control allows you to notify a host software (Camera SDK or a third-party software) about the events occurred (start or end of the acquisition, dropped frames, rising edge of a signal on the camera's input or output).

Parameter Name	Type	Value	Access	Description	
EventSelector ¹	Enumeration	String	Num.	RW	Selects which Event to signal to the host application.
		AcquisitionStart	0x9105		
		AcquisitionEnd	0x9106		
		Stream0TransferIntDrop	0x9107		
		MessageTransferOverflow	0x9108		
		IN1	0x9101		
		IN2	0x9102		
		OUT1	0x9103		
OUT2	0x9104				
EventNotification	Enumeration	String	Num.	RW	Activate or deactivate the notification to the host application of the occurrence of the selected Event.
		Off	0		
		On	1		

¹EventSelector values:

- **AcquisitionStart** – Device just started the acquisition of one or many frames.
- **AcquisitionEnd** – Device just completed the acquisition of one or many frames.
- **Stream0TransferIntDrop** – Stream channel internal drop.
- **MessageTransferOverflow** – Message channel FIFO overflow.
- **IN1** – The event will be generated when a Rising Edge is detected on the Hardware Input Line GP IN 1 (TRIGGER 1).
- **IN2** – The event will be generated when a Rising Edge is detected on the Hardware Input Line GP IN 2 (TRIGGER 2) (IN2 event is supported by all cameras; except, the POE-C2000 and POE-C2400 models).
- **OUT1** – The event will be generated when a Rising Edge is detected on the Hardware Output Line GP OUT 1 (STROBE 1).
- **OUT2** – The event will be generated when a Rising Edge is detected on the Hardware Output Line GP OUT 2 (STROBE 2) (OUT2 event is supported by all cameras except for POE-C2000 and POE-C2400 models).

Configuring an Ethernet Adapter and Host Computer

For the best system performance, Imperx recommends configuring the following parameters of your network interface card (NIC): Jumbo Frames (Jumbo Packets), Receive/Transmit Buffers, Interrupt Moderation Rate to the values shown below. You also might need to disable antivirus software and Firewalls, turn off power saving plan, and configure IP addresses for multiple NICs on the host computer.

 **CAUTION**

Make sure that the version of your NIC driver is the most recent one, update it if necessary. Using an outdated version of a NIC driver might negatively affect the data transmission.

Linux:

To find the driver name, run the following command:

```
lspci -v
```

See the Kernel driver in use parameter for driver name:

```
Kernel driver in use: r8169
```

To find the driver version, run the following command:

```
modinfo <drv_name>
```

See the vermagic parameter for driver version:

```
vermagic: 5.4.0-73-generic SMP mod_unload modversions
```

Parameter	Value
Jumbo Frames (or Jumbo Packets)	9000 (9014, 16K, or 9 KB MTU)
Receive Buffers (or Receiver Descriptors)	Maximum
Transmit Buffers	Maximum
Interrupt Moderation	Enable
Interrupt Moderation Rate (or Interrupt Throttling)	Extreme

See section [Adjusting Jumbo Frames, Receive/Transmit Buffers, Interrupt Moderation Rate in Windows](#) for adjusting procedures.

NOTE  The parameter names and configuring procedures depend on the adapter model and manufacturer and may differ from the ones described in this chapter. When adjusting the adapter parameters, select the ones that relate to the parameters listed above. For more information, please refer to the NIC documentation.

Jumbo Frames

Jumbo Frames (or **Jumbo Packets**) parameter allows for payloads larger than the standard maximum transmission unit (MTU) of 1,500 bytes and supports up to 9,000 bytes per packet. Jumbo Frames are used to reduce the overhead load per packet, decrease CPU load, and increase data transfer rate. As fewer packets are needed to transfer data, the number of interrupts decreases resulting in lower overall CPU usage.

Please make sure that your network equipment (cameras, switches, routers, Network Interface Cards (NICs)) supports Jumbo frames and is configured to use the same frame size. If any network devices do not support Jumbo Frames, packets and frames drops may occur.

Most network adapters have Jumbo Packets disabled. To enable Jumbo Packet, please follow the steps in section [Adjusting Jumbo Frames, Receive/Transmit Buffers, Interrupt Moderation Rate in Windows](#).

TIP ⓘ

Connect the Cheetah GigE Vision camera to a dedicated Ethernet port and use an Ethernet adapter that supports Jumbo Packets.

Receive/Transmit Buffers

Receive Buffers (or **Receive Descriptors**) and **Transmit Buffers** parameters set the amount of system memory that can be used by the adapter driver when copying data to the memory. Typically, it is set to a low value by default (usually 256) which causes dropped packets (older packets will be overwritten). For maximum performance, Imperx recommends that you set these parameters as high as possible.

Increasing the Receive Buffers and Transmit Buffers size will improve stability and can be configured on the most systems without causing any system level interrupt. However, please keep in mind that it can negatively affect systems which have limited system memory.

NOTE *

Receive/Transmit Buffers settings do not affect your system's CPU usage.

Interrupt Moderation Rate

Interrupt Moderation Rate (or **Interrupt Throttling**) sets the maximum number of interrupts per second to the CPU when processing the transmitted and received packets.

Minimizing the interval between interrupts reduces the latency on each packet but increases CPU usage and decreases throughput. To minimize CPU usage, larger interrupt intervals are required.

Some NICs support only Interrupt Moderation control, while the others support both Interrupt Moderation and Interrupt Moderation Rate control.

When the Interrupt Moderation setting is disabled, an interrupt is created for every packet, reducing the latency on each packet. However, this significantly increases CPU usage. Enabling the Interrupt Moderation setting allows multiple packets to be processed for each interrupt lowering CPU usage.

TIP ⓘ

The Interrupt Moderation Rate can be set at about 8,000 (or Extreme) interrupts per second to achieve lower latency.

If some latency is acceptable, the Interrupt Moderation Rate can be set at about 1,000 (or Low) interrupts per second to achieve lower CPU usage.

Experiment with your system to determine the optimal setting. You can try the following options as well:

- Use the default value set by the manufacturer's drivers.
- Set a NIC to the adaptive interrupt moderation mode. In this mode, the interval is dynamically changed according to packet size and throughput.

Adjusting Jumbo Frames, Receive/Transmit Buffers, Interrupt Moderation Rate in Windows

If your network adapter has Jumbo Frames disabled, the following pop-up window opens while connecting the camera (see [Appendix A](#) on how to connect to the camera):

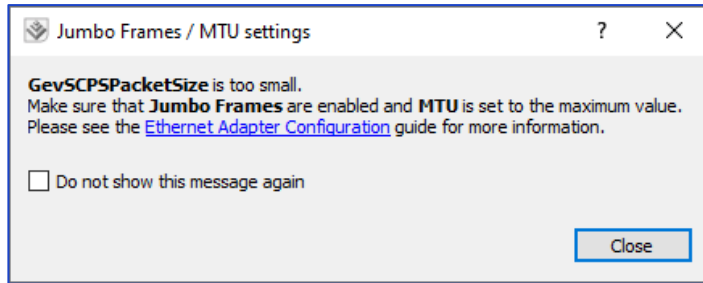

To adjust Jumbo Frames, MTU size, and other parameters, follow the steps below

1. Click **Start** icon → **Windows System** → **Control Panel**.
2. Click **Hardware and Sound** → **Devices and Printers** → **Device Manager**.
3. Expand **Network Adapters** list → Right-click the Ethernet adapter that works with your camera → **Properties**.

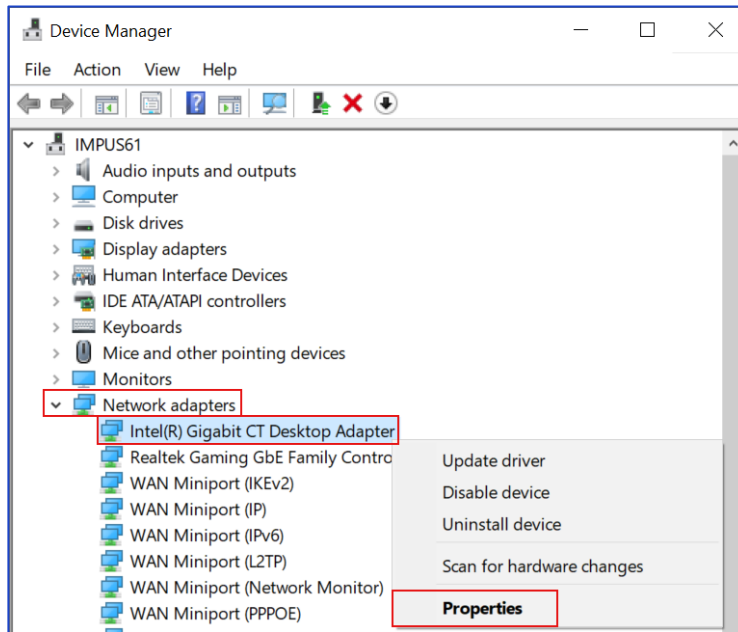

4. On the **Advanced** tab, set the following parameters:
 - **Jumbo Packet** (or **Jumbo Frame**) → Set **Value** to *9014 Bytes* (or *9 KB MTU, 9000, 16K* – depends on NIC).
 - **Receive Buffers** (or **Receive Descriptors**) → Set to the maximum value possible.
 - **Transmit Buffers** → Set to the maximum value possible.
 - **Interrupt Moderation** → *Enable*.
 - **Interrupt Moderation Rate** (or **Interrupt Throttling**) → Set to *Extreme*.

At higher data rates, the Extreme setting may improve system performance. At lower data rates, a Low setting is preferred, since delayed interrupts cause additional latency.

If **Jumbo Packet** or **Jumbo Frame** is absent from the list, your NIC does not support Jumbo Packets. Maximum camera performance cannot be achieved.

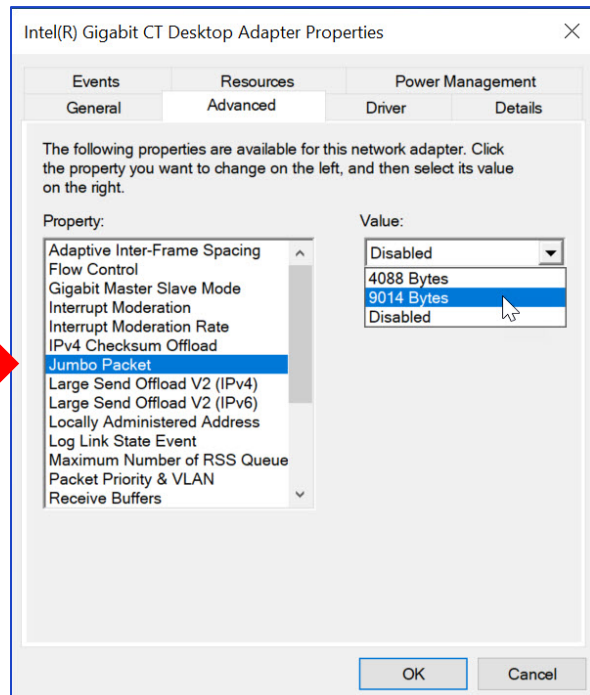



5. Click **OK**. The network connectivity may be lost for a couple of seconds.
6. Reboot your PC to ensure that new settings have been activated.

Enabling Jumbo Frames in Linux

To enable Jumbo Frames and set MTU size to 9000 using the console, run the following command:

```
sudo ip link set <eth_link_name> mtu 9000
```

To enable Jumbo Frames and set MTU size to 9000 using the Network Settings in the Ubuntu GUI, follow the steps below:

1. In the top right-hand corner of the screen, click the Wired Network icon  → Settings  → Network → select the Ethernet adapter that works with your camera → click the  button.
2. On the Identity tab, set the MTU size to 9000 bytes and click Apply:

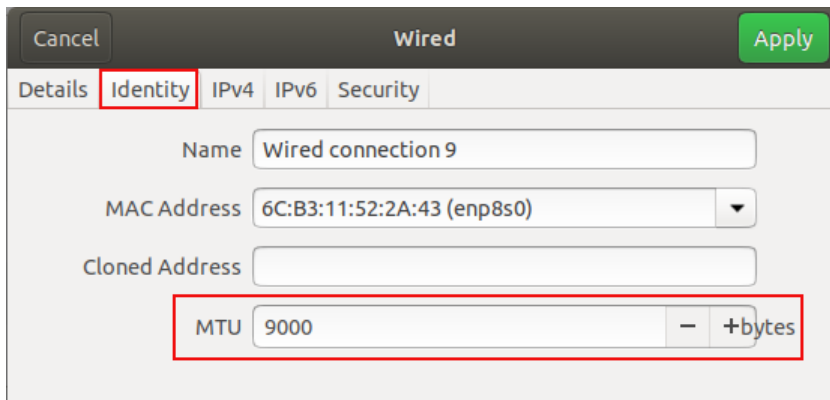

Adjusting Receive/Transmit Buffers in Linux

To set RX/TX buffer size, use the **ethtool** utility.

1. If the **ethtool** utility is not installed, run the following command to install it:

```
sudo apt-get install ethtool
```

2. Find the maximum RX/TX values by running the following command:

```
ethtool -g <eth_link_name>
```

```
tester@kola-ubuntu18:~$ ethtool -g enp6s0
Ring parameters for enp6s0:
Pre-set maximums:
RX:                4096
RX Mini:           0
RX Jumbo:          0
TX:                4096
Current hardware settings:
RX:                512
RX Mini:           0
RX Jumbo:          0
TX:                512
```

3. Set the maximum RX/TX (as shown above, rx-max = 4096, tx-max=4096) by running the following command:

```
sudo ethtool -G <eth_link_name> rx 4096 tx 4096
```

```
tester@kola-ubuntu18:~$ sudo ethtool -G enp6s0 rx 4096 tx 4096
tester@kola-ubuntu18:~$ ethtool -g enp6s0
Ring parameters for enp6s0:
Pre-set maximums:
RX:                4096
RX Mini:           0
RX Jumbo:          0
TX:                4096
Current hardware settings:
RX:                4096
RX Mini:           0
RX Jumbo:          0
TX:                4096
```

Configuring a Host Computer in Windows

This section describes how to disable the Windows Firewall, turn off the power saving plan, and configure IP addresses for multiple NICs on the host computer.

Antivirus software, Firewalls, or third-party filter drivers may impact the efficiency of the system resulting in an excessive number of dropped frames and slow video streaming.

When too many frames have been dropped, the video acquisition rate slows down. The following pop-up window opens:

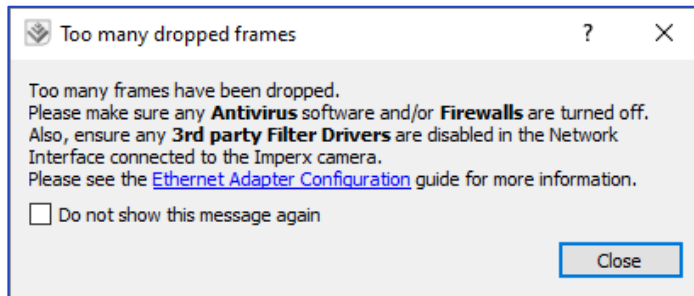

Imperx recommends **turning off** any Firewalls, antivirus software, and third-party filter drivers and to disable Windows Performance Monitor (perfmon.exe) or Wireshark (use it solely for debugging purposes), and not opening the Networking tab in Windows Task Manager.

To turn off the Firewall, please refer to the sections [Disabling Windows Firewall for All Connections](#) and [Disabling Windows Firewall for Selected Network Adapters](#).

Please contact your IT Department on turning off antivirus software and any third-party filter drivers.

Disabling Windows Firewall for All Connections

1. Click **Start** icon → **Windows System** → **Control Panel**.
2. Click **System and Security** → **Windows Defender Firewall**.
3. On the left panel, click **Turn Windows Defender Firewall on or off**. The **Customize settings** windows opens.
4. Select a network type that your camera is connected to and click **Turn off Windows Defender Firewall (not recommended)**. Click **OK**.

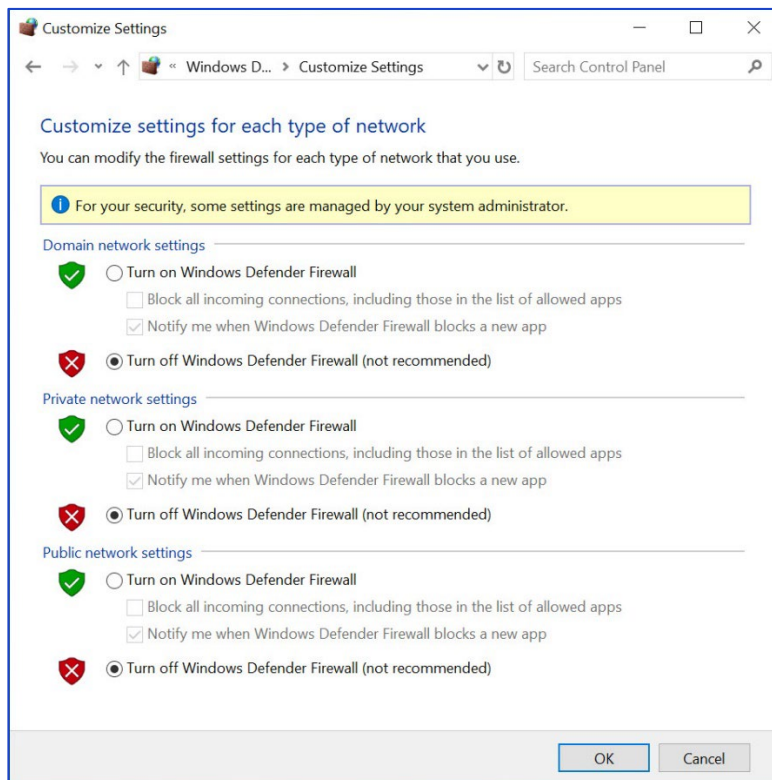

Disabling Windows Firewall for Selected Network Adapters

1. Click **Start** icon → **Windows System** → **Control Panel**.
2. Click **System and Security** → **Windows Defender Firewall**.
3. On the left panel, click **Advanced settings**. The **Windows Defender with Advanced Security** windows opens.
4. Click **Windows Defender Firewall Properties**.

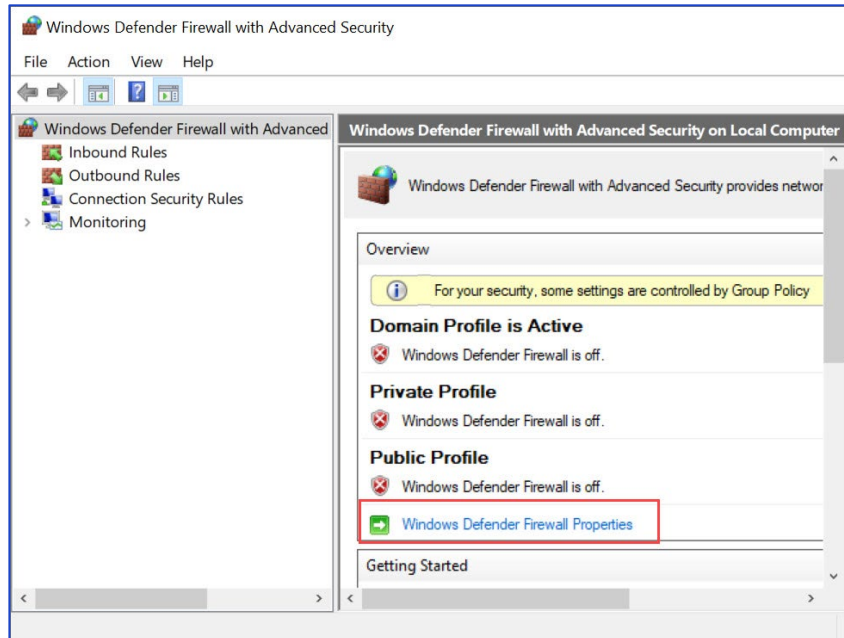

5. In the **Windows Defender Firewall with Advanced Security on Local Computer Properties...** window, select the tab of the profile to turn off the firewall and click **Customize...**

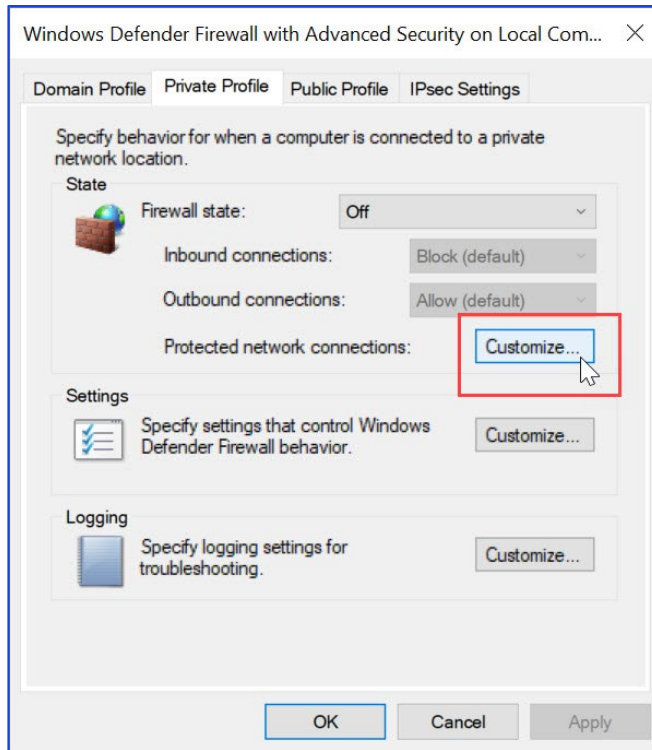

6. The **Protected Network Connections for the Private Profile** windows shows a list of the network connections with the firewall turned on. To disable the firewall, uncheck those connections that contain your cameras. Click **OK**.

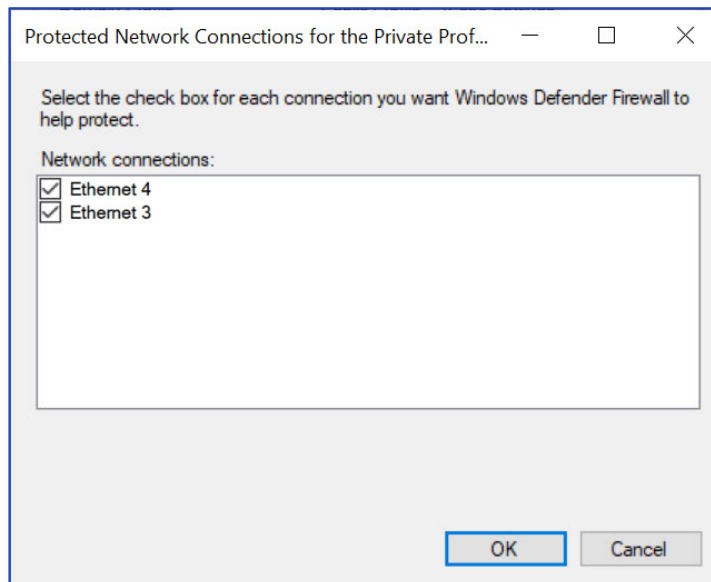

Configuring IP Addresses

Camera and NIC IP addresses must be in the same subnet. To assign a unique IP address to a NIC, you can use one of the following methods:

Method	When to use
Configure a static IP address	In networks without a DHCP server, if cameras have persistent IP address specified
Configure a dynamic IP address via DHCP	In networks with a DHCP server installed
Link-Local IP Addressing	In the absence or failure of static or dynamic address configurations

TIP ⓘ

Before assigning a dynamic IP address configuration, please make sure that a DHCP server is running in your network. The DHCP server assigns the IP address to each NIC and camera with DHCP/Auto IP setting enabled.

If the DHCP server is not running in the network, you can use the LLA configuration or manually assign static IP addresses to each NIC and GigE Vision camera.

Configuring a Static IP Address in Windows

1. Click **Start** icon → **Windows System** → **Control Panel**.
2. Click **Network and Internet** → **Network and Sharing Center**.
3. On the left panel, click **Change adapter settings**.
4. Right-click the Ethernet adapter that works with your camera → **Properties**.
5. Select Internet **Protocol Version 4 (TCP/IPv4)**, click **Properties**.

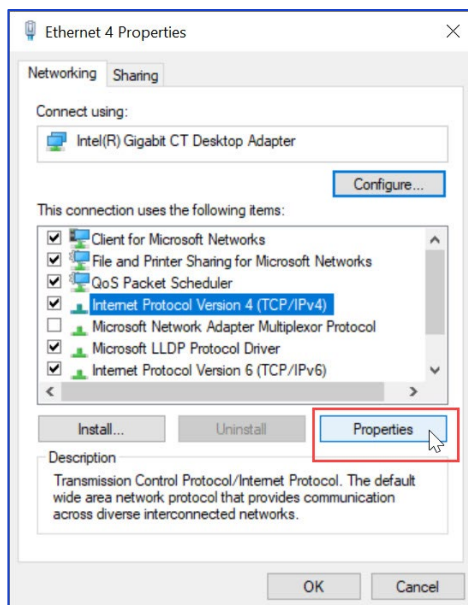

6. Select **Use the following IP address** and assign an IP address to the network adapter. The **Default gateway** field should be blank.

Imperx recommends using a private network IP address. The following IPv4 address ranges are reserved for private networks:

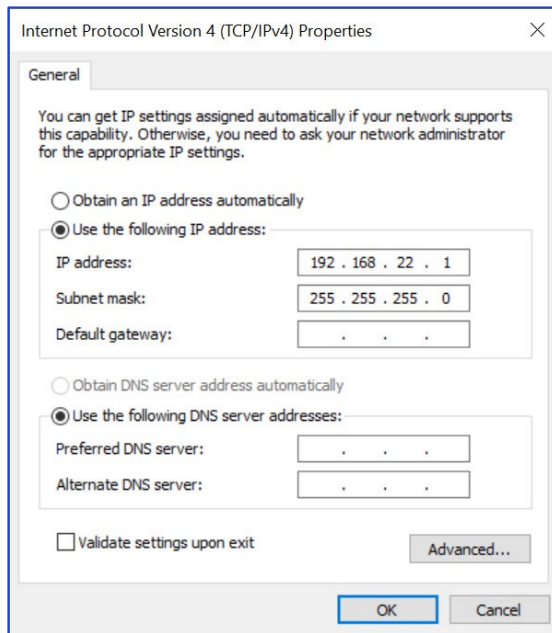

RFC1918 name	IP address range	Largest CIDR block (subnet mask)
24-bit block	10.0.0.0–10.255.255.255	10.0.0.0/8 (255.0.0.0)
20-bit block	172.16.0.0–172.31.255.255	172.16.0.0/12 (255.240.0.0)
16-bit block	192.168.0.0–192.168.255.255	192.168.0.0/16 (255.255.0.0)



7. Click **OK**.
8. Repeat steps 4–7 for each NIC on your computer.

Configuring a Static IP Address in Linux

To assign a static IP address manually, follow the steps below.

1. In the top right-hand corner of the screen, click the **Wired Network** icon  → **Settings**  → **Network** → select the Ethernet adapter that works with your camera → click the  button.

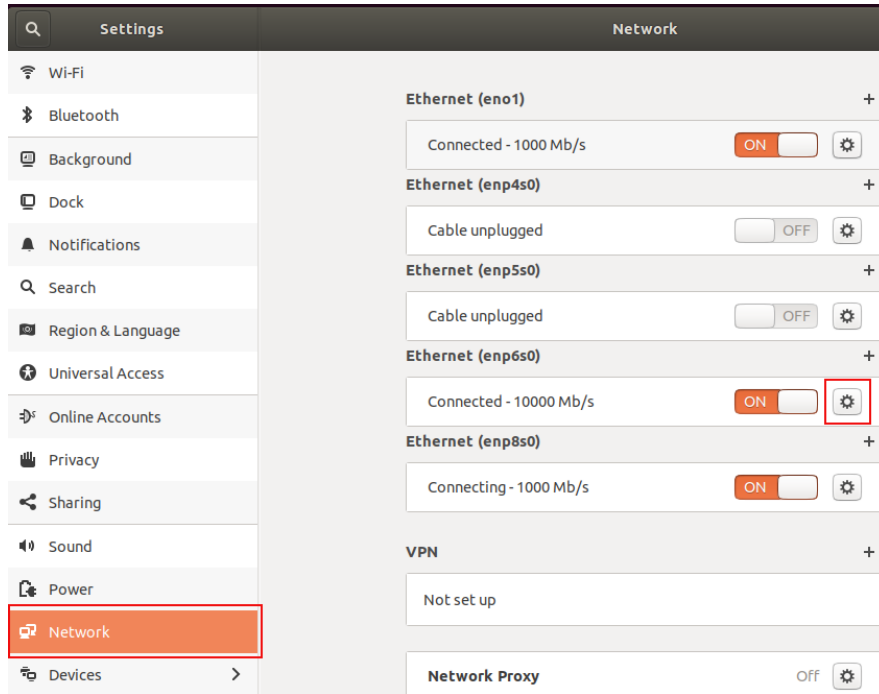

2. On the **IPv4** tab, set **IPv4 Method** to **Manual** and enter an IP address and Netmask in the Addresses area. The **Gateway**, **DNS**, and **Routes** fields should be left blank.

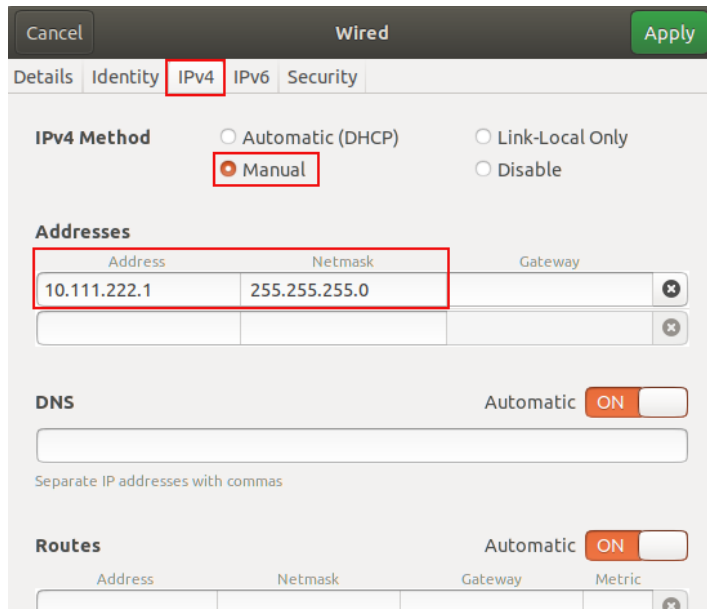

Imperx recommends using a private network IP address. The following IPv4 address ranges are reserved for private networks:

RFC1918 name	IP address range	Largest CIDR block (subnet mask)
24-bit block	10.0.0.0–10.255.255.255	10.0.0.0/8 (255.0.0.0)
20-bit block	172.16.0.0–172.31.255.255	172.16.0.0/12 (255.240.0.0)
16-bit block	192.168.0.0–192.168.255.255	192.168.0.0/16 (255.255.0.0)

3. Click **Apply**.
4. Repeat steps 1–3 for each NIC on your computer.

Configuring an IP Address Using DHCP in Windows

For a NIC to obtain an IP address automatically, follow the steps below.

1. Click **Start** icon → **Windows System** → **Control Panel**.
2. Click **Network and Internet** → **Network and Sharing Center**.
3. On the left panel, click **Change adapter settings**.
4. Right-click the Ethernet adapter that works with your camera → **Properties**.
5. Select Internet **Protocol Version 4 (TCP/IPv4)**, click **Properties**.

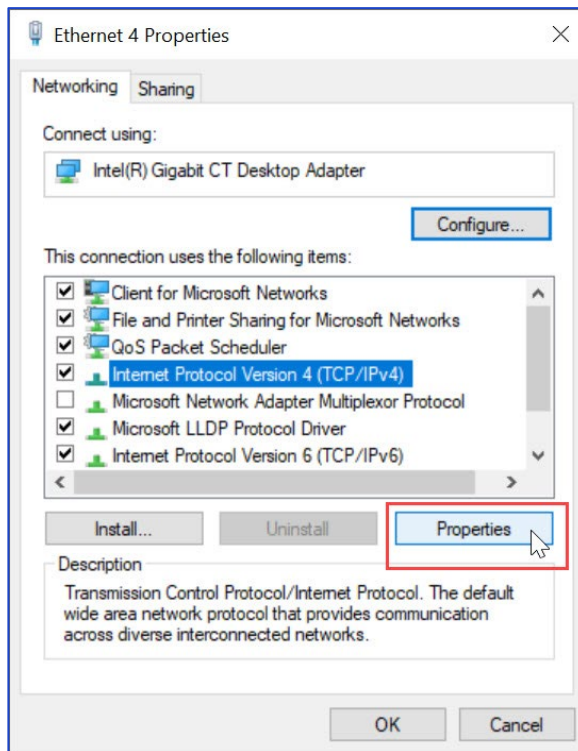

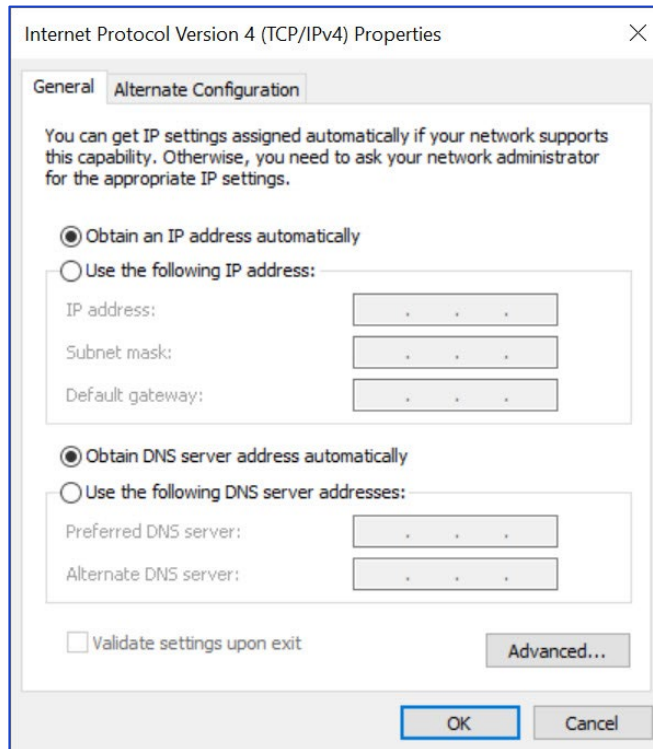

6. Make sure that **Obtain an IP address automatically** is enabled.



NOTE (*) The DHCP server assigns a dynamic IP address to the NIC and camera. If the DHCP server is not available/ not running, a link-local address assignment takes place.

Configuring an IP Address Using DHCP in Linux

For a NIC to obtain an IP address automatically, follow the steps below.

1. In the top right-hand corner of the screen, click the **Wired Network** icon  → **Settings**  → **Network** → select the Ethernet adapter that works with your camera → click the  button.

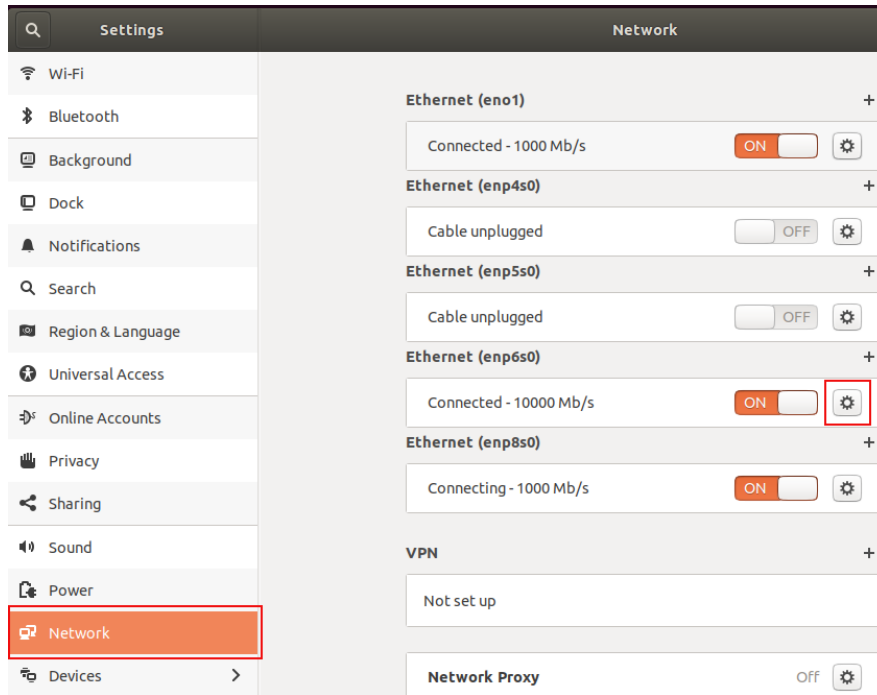

2. On the **IPv4** tab, set **IPv4 Method** to **Automatic (DHCP)** and click **Apply**.

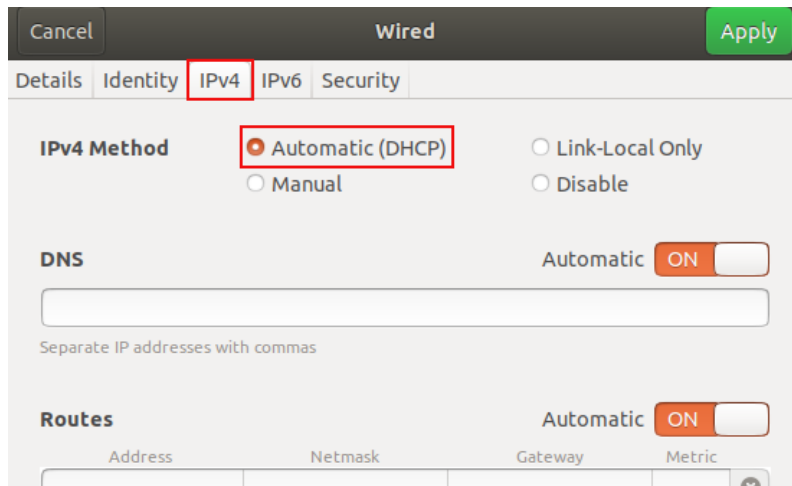

3. Repeat steps 1, 2 for each NIC that is connected to a camera and has a running DHCP server.

NOTE ⚠ The DHCP server assigns a dynamic IP address to the NIC and camera. If the DHCP server is not available/not running, a link-local address assignment takes place.

Link-Local IP Address



A NIC assigns a link-local IP address automatically when a static IP address has not been configured and a DHCP is not enabled. This address is valid only for a local network and is not routable.

The IPv4 address range is 169.254.0.0–169.254.255.255.

When a static IP address or DHCP becomes available, assign a new IP address instead of the link-local address.

Configuring a Link-Local Address in Linux

For a NIC to obtain a link-local IP address, follow the steps below.

1. In the top right-hand corner of the screen, click the Wired Network icon  → **Settings**  → **Network** → select the Ethernet adapter that works with your camera → click the  button.

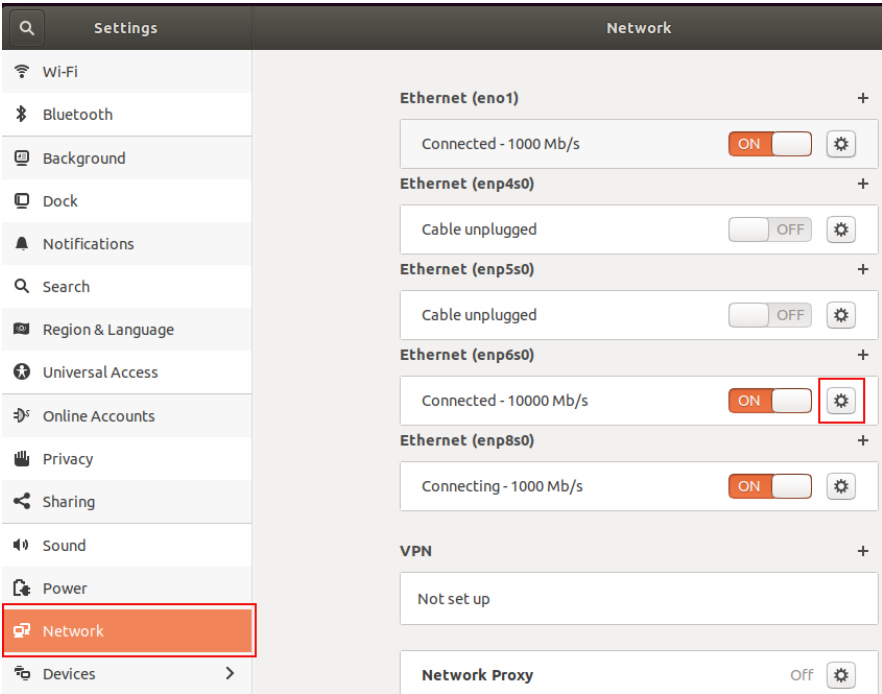

2. On the **IPv4** tab, set **IPv4 Method** to **Link-Local Only** and click **Apply**.

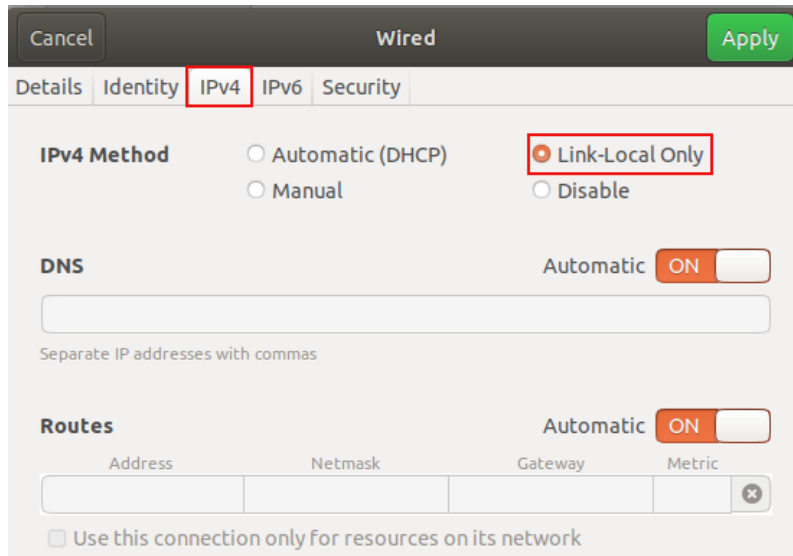

3. Repeat steps 1, 2 for each NIC on your computer.

Configuring a Persistent IP Address for a Camera

A camera has the following default parameters:

LLA	True (Enabled)
DHCP	True (Enabled)
Persistent IP	False (Disabled)
Subnet Mask	255.255.0.0
Default Gateway	0.0.0.0

To set a persistent IP address, subnet mask, and default gateway, follow the steps below:

1. Open the IpxPlayer application and click Camera menu and select Connect (or click the

Connect icon  on the tool bar).

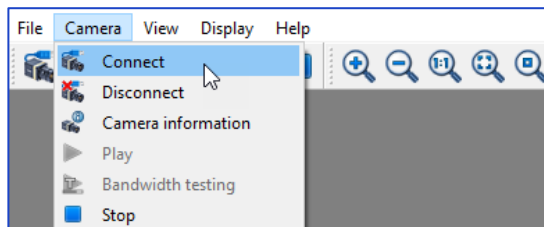

2. Select a camera and click **Set IP Address**.

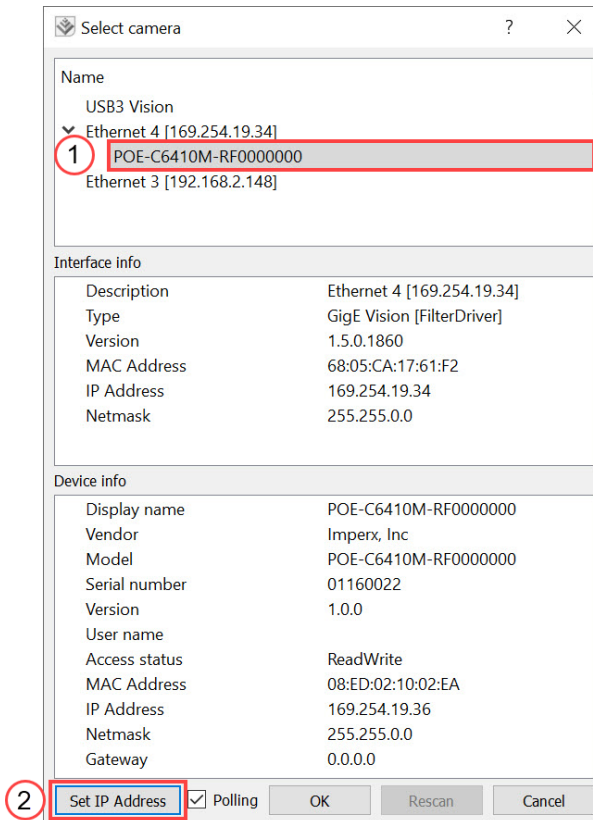

- Set IP Address, Subnet Mask, and Default Gateway to values that will meet your network constraints and then click **OK**.

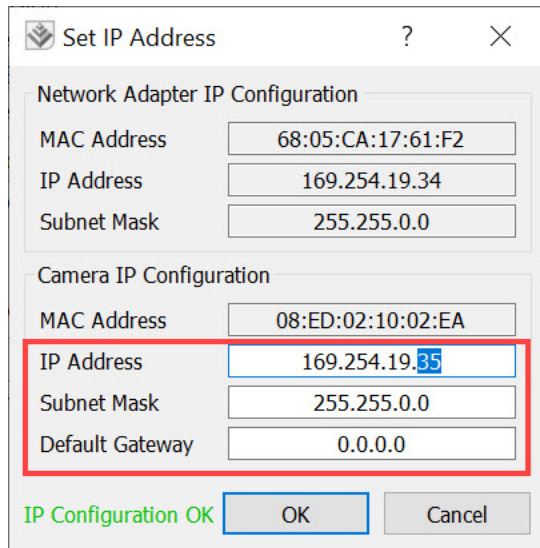

Set IP Address

Network Adapter IP Configuration

MAC Address: 68:05:CA:17:61:F2

IP Address: 169.254.19.34

Subnet Mask: 255.255.0.0

Camera IP Configuration

MAC Address: 08:ED:02:10:02:EA

IP Address: 169.254.19.35

Subnet Mask: 255.255.0.0

Default Gateway: 0.0.0.0

IP Configuration OK

- In the **TransportLayerControl** category, make sure that the following parameters are configured:
 - GevCurrentIPConfigurationPersistenIP*: True
 - GevPersistentIPAddress*: What you set it to previously
 - GevPersistentSubnetMask*: What you set it to previously
 - GevPersistentDefaultGateway*: What you set it to previously

TransportLayerControl	
PayloadSize	31492800
GigEVision	
GevMACAddress	08:ED:02:10:02:EA
Enable Extended ID Mode	Off
GevCurrentIPConfigurationLLA	True
GevCurrentIPConfigurationDHCP	True
GevCurrentIPConfigurationPersistenIP	True
GevCurrentIPAddress	169.254.19.35
GevCurrentSubnetMask	255.255.0.0
GevCurrentDefaultGateway	0.0.0.0
GevPersistentIPAddress	0.0.0.0
GevPersistentSubnetMask	0.0.0.0
GevPersistentDefaultGateway	0.0.0.0
GevLinkSpeed	1000
GevFirstURL	LOCAL:lpvGev_CheetahPregius_1.5.9.zip;30
GevSecondURL	
GevCCP	ExclusiveAccess
GevPrimaryApplicationSocket	51371
GevPrimaryApplicationIPAddress	169.254.19.34

Configuring Power Management in Windows

For applications with extended periods of image streaming, configuring power management is required. Typically, if there is no activity from the keyboard or mouse, the computer or NIC will go to sleep, and the image stream will be interrupted. To prevent Windows from powering down the NIC or computer, you need to change the power plan settings.

To change power plan settings for the computer:

1. Click **Start** icon → **Windows System** → **Control Panel**.
2. Click **Hardware and Sound** → **Power Options**.
3. Next to the power plan, click **Change plan settings**.

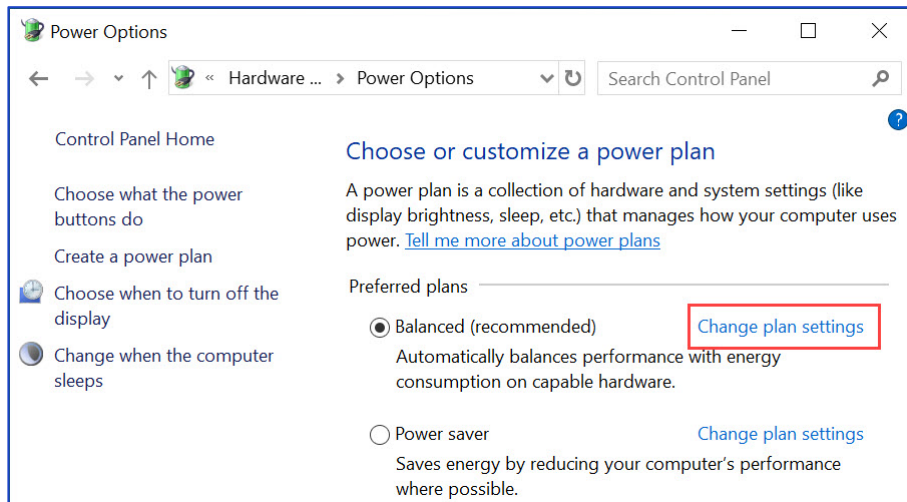

4. In the **Put the computer to sleep** dropdown list select **Never** and click **Save changes**. **Turn off display** can be set to any value.

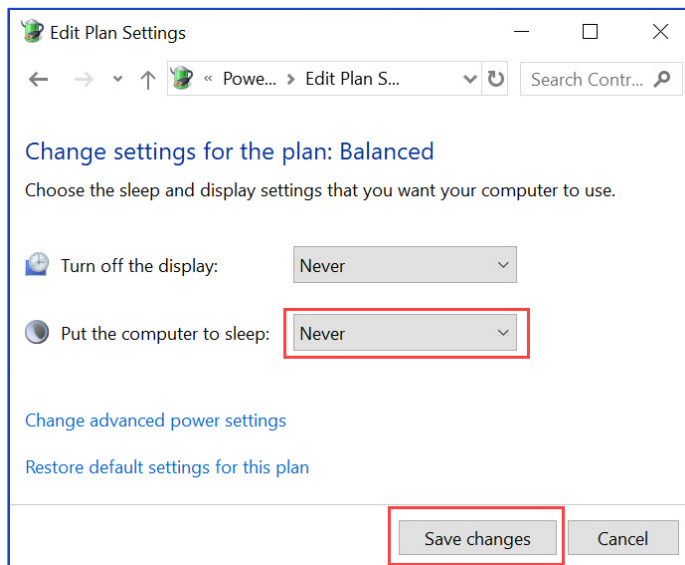

To change power plan settings for the NIC:

1. Click **Start** icon → **Windows System** → **Control Panel**.
2. Click **Network and Internet** → **Network and Sharing Center**.
3. On the left panel, click **Change adapter settings**.
4. Right-click the Ethernet adapter that works with your camera → **Properties**.
5. Click **Configure**. Adapter Properties window opens.
6. On the **Power Management** tab, uncheck the **Allow the computer to turn off this device to save power** option, click **OK**.
7. Repeat steps 4–6 for each NIC.

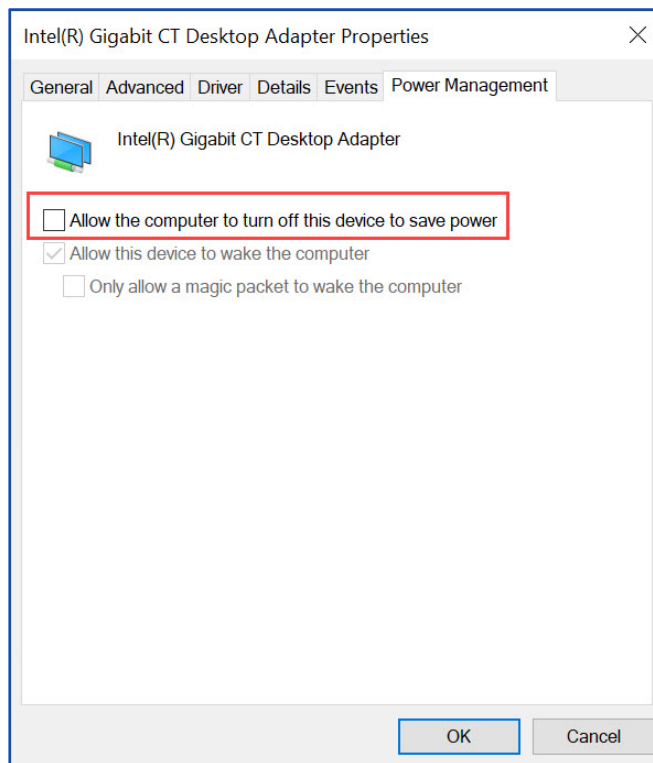

Enabling Imperx Filter Driver in Windows

Imperx recommends enabling Filter Driver when multiple GigE Vision cameras are connected to a host computer. It allows to prevent or significantly reduce frame drops.

The Imperx Filter Driver is available in Imperx Camera SDK ver.1.5.x.xxxx or later. Make sure that the version of your Camera SDK is the most recent one, update it if necessary. The Filter driver installs during the Camera SDK installation. To download the most recent Camera SDK version, visit the Imperx website <https://www.imperx.com/subscribers/downloads/>.

You can install Filter Driver yourself by running the executable file that is located in SDK binaries folder C:\Program Files\Imperx\Imperx Camera SDK\bin\win64_x64 \IpxGEVFilterInstaller.exe. On the **Imperx GigE Vision filter driver installer** screen, select network adapters that are connected to Imperx GigE Vision cameras, click **Enable IpxGEV Filter driver**, and close the filter driver installer.

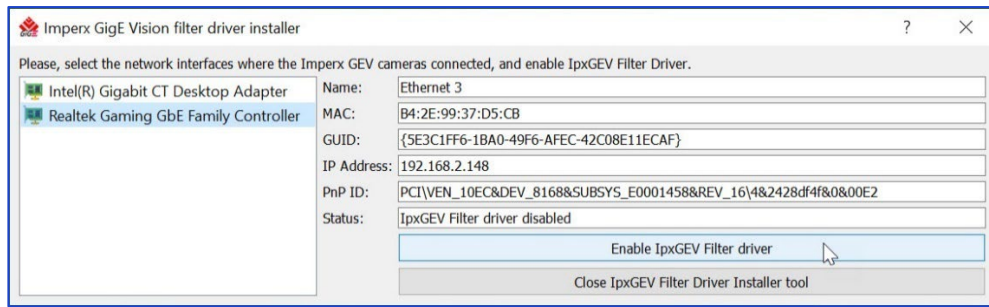

When installed, the Filter Driver appears in Ethernet connection properties. Make sure that the **Imperx GigE Vision Filter** check box is checked. (If it is unchecked, the Filter Driver is disabled.)

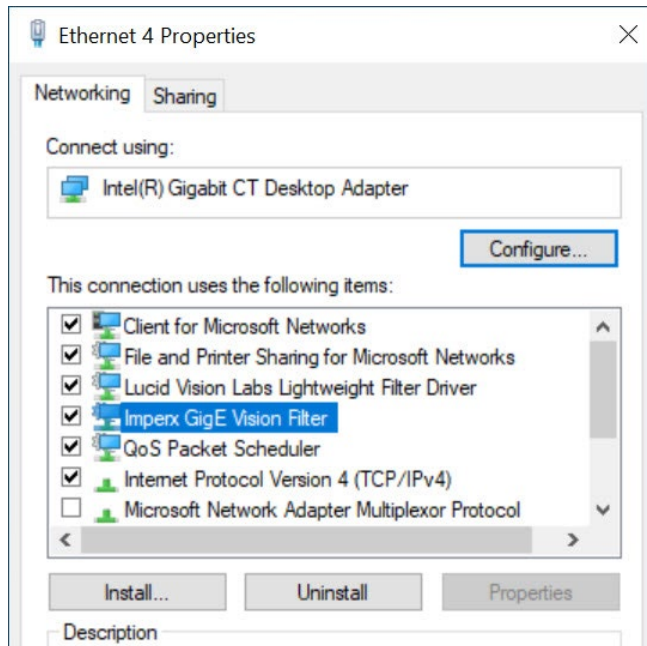

The Filter Driver also appears, if installed and enabled, in the Select camera dialog (in SDK or IpxPlayer), when you select NIC or camera.

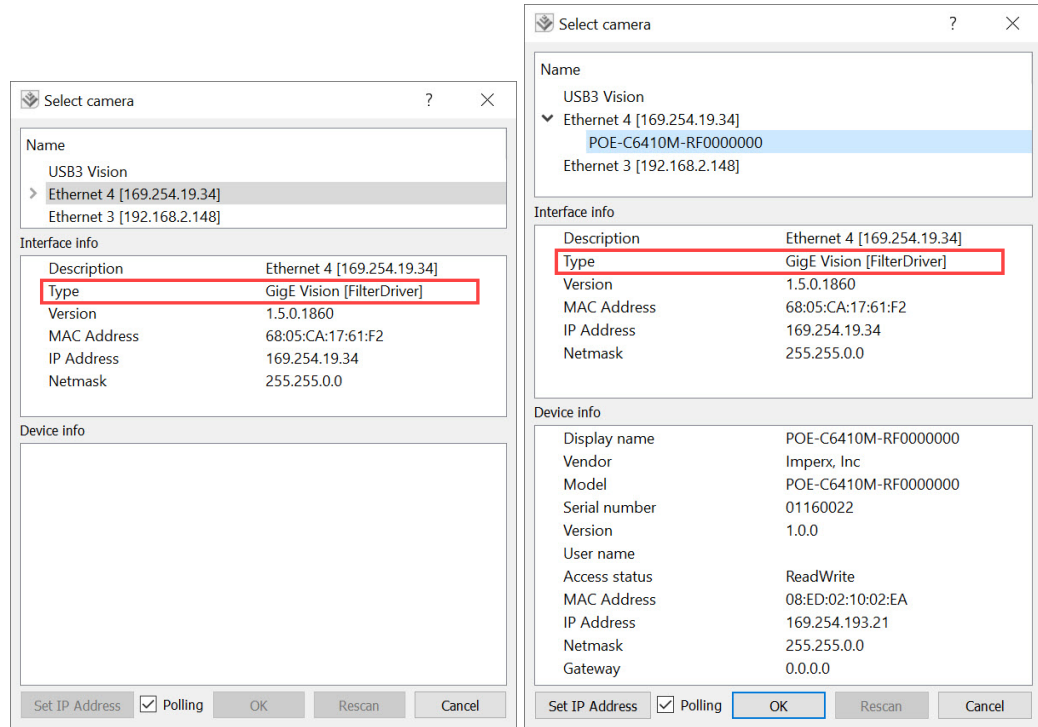

If the Filter Driver is disabled or not installed, GigE Vision [UDP] will be displayed:

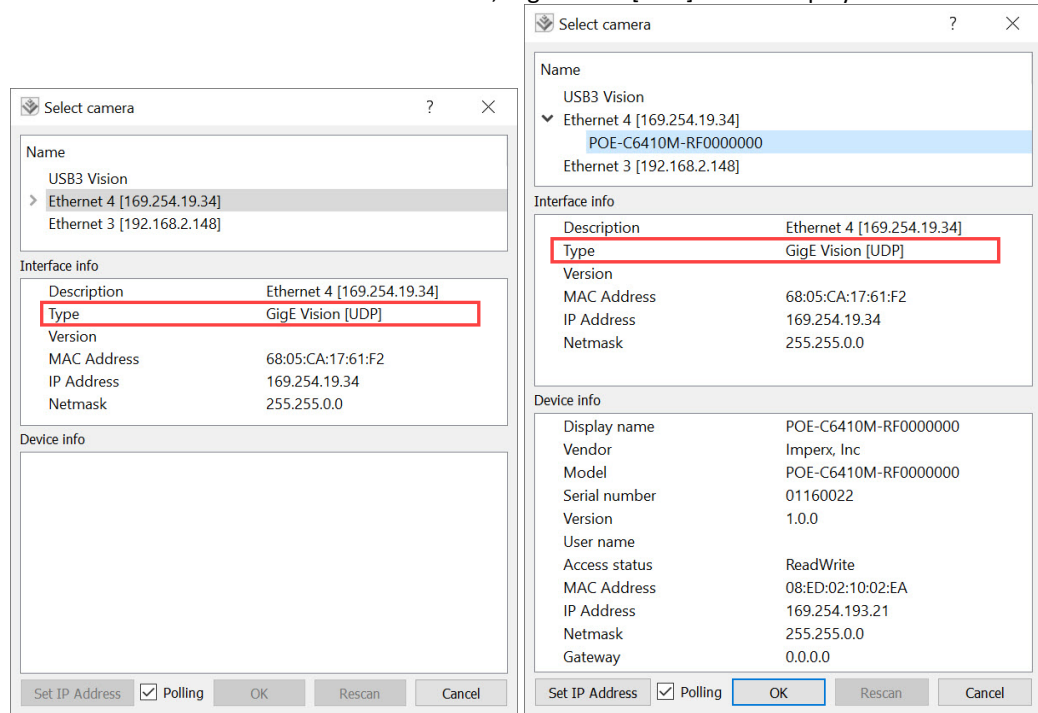

Camera's UDP Ports

A standard GigE Vision Control Protocol (GVCP) port is a UDP port used to receive camera commands. The Internet Engineering Task Force (IETF) has designated port number 3956 as the standard GVCP port. For multi-service device, this is the port attached to the first service.

The camera Outgoing UDP port for Control Channel GVCP packets is 3956 (0x0F74), while the incoming port on SW side - can be any dynamic port within the range 49152–65535.

The camera Outgoing Stream Channel UDP port for GigE Vision Stream Packets (GVSP) is 3011 (0x0BC3) for FW v1.*, and 49153 (0xC001) for FW v2.*. The incoming port on SW side is any dynamic port within the range 49152–65535.

The camera Outgoing UDP port for Message Channel GVCP packets is 49152 (0xC000), while incoming port on SW side is any dynamic port within the range 49152–65535.

Software GUI

Overview

The IpxPlayer software application provides a graphical user interface (GUI) with functionality for controlling Imperx camera parameters, acquiring video, showing acquired video, and saving acquired images or video on the host computer.

The application also collects and displays statistical information on acquired images and generates a log of data transfers between the camera and the host computer.

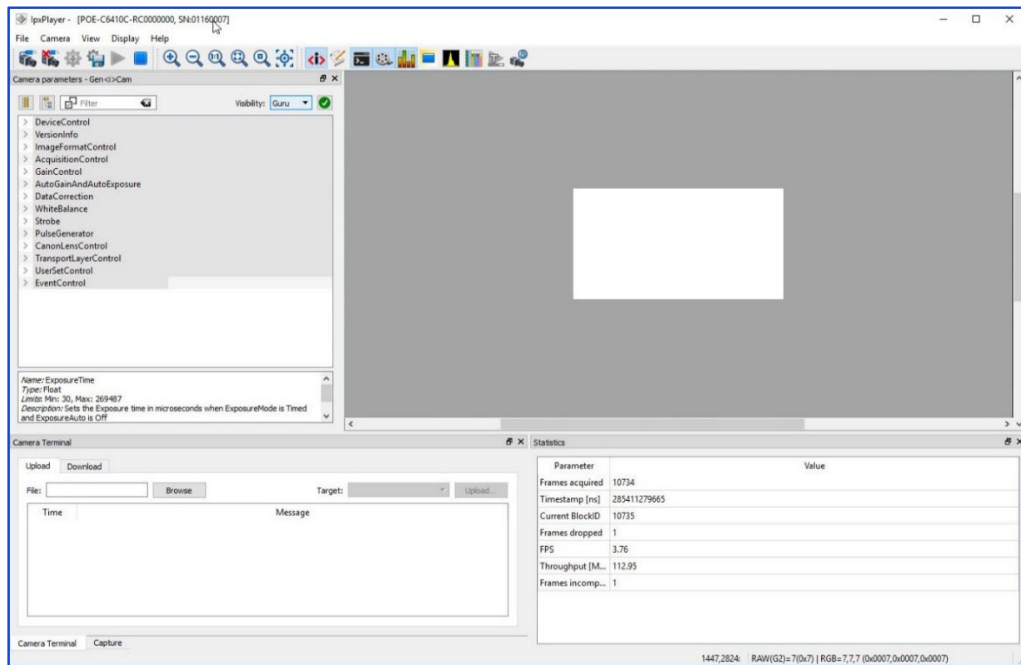

Supported Operating Systems

The Imperx Camera SDK and IpxPlayer application are compatible with the following operating systems:

- Windows 10, 32-bit and 64-bit
- Ubuntu Linux 18.04 64-bit
- Ubuntu Linux 18.04 64-bit, ARM CPU
- Ubuntu Linux 20.04 64-bit

Compatibility

The Imperx Camera SDK and IpxPlayer are compatible with the Imperx GigE Vision and USB3 cameras.

User Interface and Functionality

The IpxPlayer provides the following functionalities:

- Detects a camera.
- Connects to the camera and will run multiple instances of applications.
- Controls camera parameters (gain, exposure, trigger, white balance, and so on) using the GenICam node tree GUI.
- Logs all protocol-related data (commands, images, events, and so on) transferred between the camera and host computer.
- Shows live video from the selected camera.
- Saves acquired video images or series of images to files.
- Saves and loads camera configuration files.

Installing the Software in Windows

Use the installation wizard to install the Imperx Camera SDK software supplied with your camera.



If a previous version of the Camera SDK software is installed on your computer, you must remove it before completing the installation. The installation wizard will do this for you during the installation process. Or, you can uninstall a previous version yourself.

To remove previous versions yourself:

1. Open **Control Panel** on your computer.
2. Select **Programs and Features**.
3. Select Imperx Camera SDK and click **Uninstall**.

Installation

1. Drag the `IpxCameraSdk***.exe` file to your computer desktop. If a Security screen appears, click **OK**.

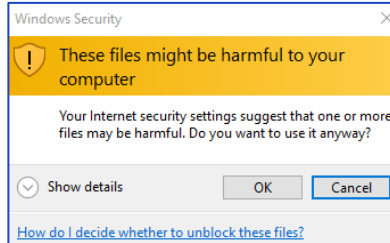

2. Double click the executable file `IpxCameraSdk***.exe`. Note the recommendation to close other applications and click **Next**.



3. Read the License Agreement and click **I Agree**.

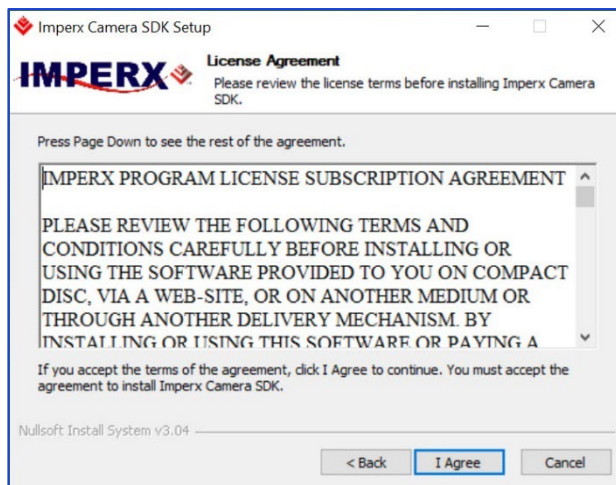

4. Select all the Cheetah Camera SDK components and click **Next**.

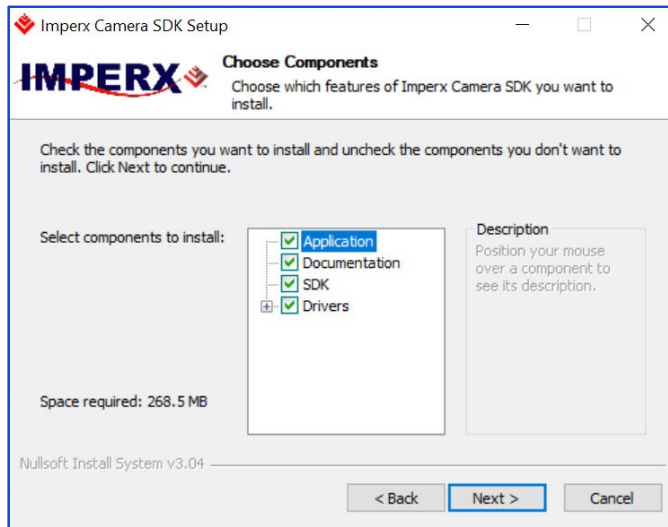

5. Accept the default destination folder or click **Browse** and select a different location, click **Next** and then **Install**.

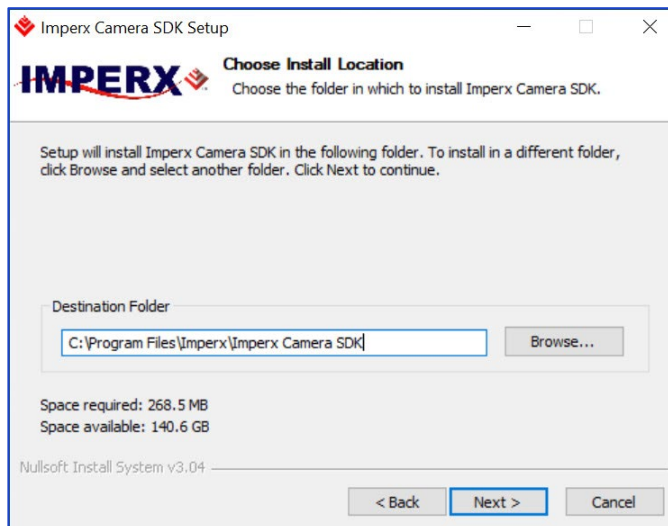

The installer prompts you to uninstall any existing versions of the software from your computer before continuing the installation.



6. Select network adapters that are connected to Imperx GigE Vision cameras, click **Enable IpxGEV Filter driver**, and close the filter driver installer.

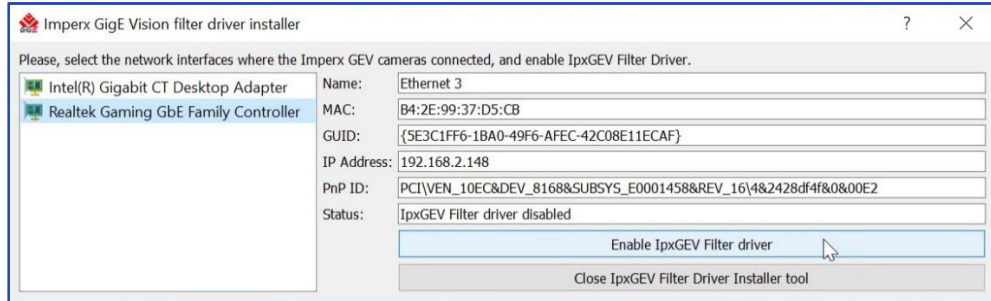

7. Make sure that the environment variable setup is checked and click **Next**.

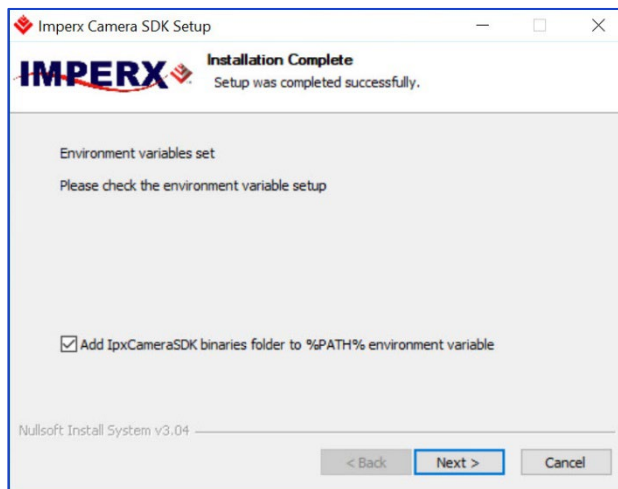

8. Read the warning message and click **Next**.
After finishing the installation, be sure to configure your Ethernet adapter and host computer before running the Cheetah camera. Refer to the [Configuring an Ethernet Adapter and Host Computer](#) chapter on page 109 for more information.

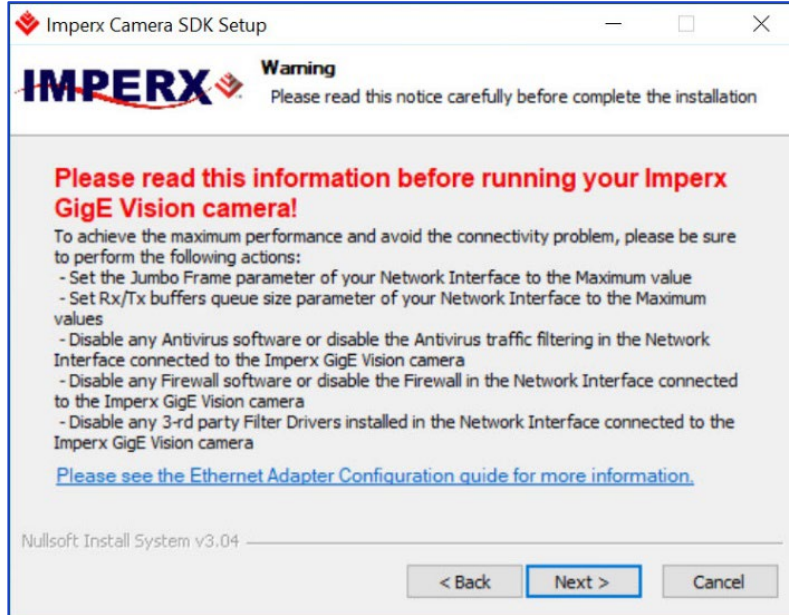

9. Select **Reboot now** and click **Finish**. The Imperx IpxPlayer icon appears on your desktop.



Installing the Software in Linux

1. Run the IpxCameraSDK installer using the console:

```
tester@kola-ubuntu18:~$ ./IpxCameraSDK_1.5.0.54-Ubuntu_18.04-x86_64.sh
```

2. Read the Warning message and press Enter

```
tester@kola-ubuntu18:~$ ./IpxCameraSDK_1.5.0.54-Ubuntu_18.04-x86_64.sh
IpxCameraSDK Installer Version: 1.5.0.54, Copyright (c) Imperx, Inc.

This is a self-extracting archive.

*****
WARNING:
*****
If you are planning to display an image that is greater than 7MB. You must
login as root to modify the usbfs_memory_mb. You can modify the size of the
usbfs memory if needed by editing:

'/sys/module/usbcore/parameters/usbfs_memory_mb' file.

For example:

sudo sh -c "echo 1000 > /sys/module/usbcore/parameters/usbfs_memory_mb"

or

just run the "manage_usbfs_memory_size.sh" script as sudo which is
located in the "bin/Linux64_x64" installed directory

Press enter to continue.
█
```

3. Read the Note message and press Enter:

```
*****
NOTE:
*****
This 'usbfs_memory_mb' command must be reset each time you reboot your system.
Please consult with your system administrator for further instructions on
how to set this usbfs_memory_mb value permanently.
If your init system is systemd, you can use "usbfs-memsize-systemd.service"
file to set desired size of usbfs_memory_mb(default 1000) permanently.
Just copy "usbfs-memsize-systemd.service" to /etc/systemd/system directory
and run following commands: cd /etc/systemd/system
sudo systemctl enable usbfs-memsize-systemd.service

Press enter to continue.
█
```

4. Read the Warning message and type Y or N

```
*****
WARNING:
*****
You are running this script as a regular user!

To be able to use the USB3 Vision Device you must add
an udev rule to the system to allow the regular user to access the device.

If you proceed as a regular user, you will not be able to install the udev
rule. However, you can do this action later by running the
"manage_udevrules.sh" script as sudo. This script is located in the
"bin/Linux64_x64" installed directory.

Would you like to proceed? [Yn]:

```

5. Accept the default destination directory or change it

```
The archive will be extracted to:
/home/tester

You can change the default directory to your specified location by running
the archive with the flag --prefix=dir

For example:
"./IpxCameraSDK-1.5.0.54-Ubuntu_18.04-x86_64.sh --prefix=/opt/imperx"

If you want to stop extracting, please press <ctrl-C>.

By default the IpxCameraSDK will be installed in:
"/home/tester/IpxCameraSDK-1.5.0.54"

Do you want to include the subdirectory IpxCameraSDK-1.5.0.54?

Typing 'n' will install it at the following location:
"/home/tester" [Yn]:

```

```
Using target directory: /home/tester/IpxCameraSDK-1.5.0.54
Extracting, please wait...

Unpacking finished successfully!

Installed successfully!
Thank you for using IpxCameraSDK!
```

6. To open the IpxPlayer application, run the following command:

```
tester@kola-ubuntu18:~$ cd ~/IpxCameraSDK-1.5.0.54/bin/Linux64_x64/
tester@kola-ubuntu18:~/IpxCameraSDK-1.5.0.54/bin/Linux64_x64$ sudo ./manage_rp_filter.sh
[sudo] password for tester:
Setting rp_filter mode to 'Strict Reverse Path'...
For all the system's interfaces
Setting rp_filter mode to 'Strict Reverse Path' DONE
tester@kola-ubuntu18:~/IpxCameraSDK-1.5.0.54/bin/Linux64_x64$ sudo ./manage_socket_buffer_size.sh
Setting socket write maximum buffer size to 10485760 bytes
Setting socket read maximum buffer size to 10485760 bytes
tester@kola-ubuntu18:~/IpxCameraSDK-1.5.0.54/bin/Linux64_x64$ sudo ./manage_usbfs_memory_size.sh
Setting usbfs memory size to 1000 ...
usbfs memory size has been set to 1000
tester@kola-ubuntu18:~/IpxCameraSDK-1.5.0.54/bin/Linux64_x64$ ./IpxPlayer
```

Camera SDK

The installation process places the Imperx camera SDK files on your computer’s hard drive using following structure:

<InstallationFolder> – root SDK folder (usually, on the Windows OS, it is C:\Program Files\Imperx\Imperx Camera SDK\).

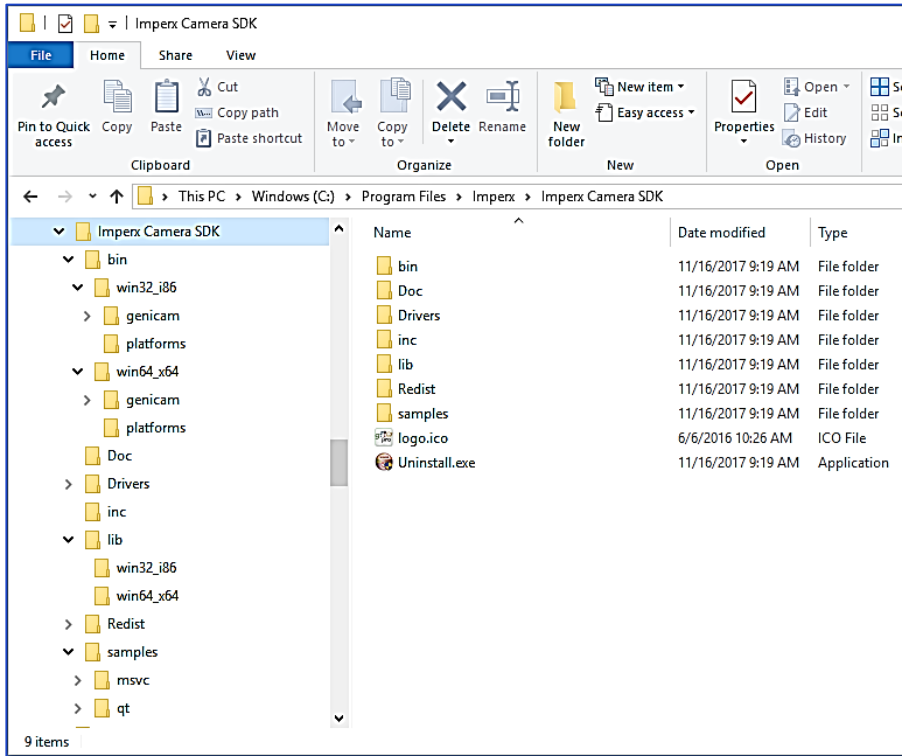

<InstallationFolder> \bin\ – contains SDK binary executable files, including SDK dynamic libraries and IpxPlayer application executable

<InstallationFolder> \Doc\ – contains SDK user manual files

<InstallationFolder> \inc\ – contains SDK C++ header files

<InstallationFolder> \lib\ – contains SDK C++ library files

<InstallationFolder> \samples\ – contains SDK C++, C#, Python samples

<InstallationFolder> \Drivers\ – contains kernel drivers for Imperx USB3 cameras

Connecting to Cameras

1. Locate and open the IpxPlayer from your desktop.
2. Click **Camera** menu and select **Connect** (or click the camera icon ).
The Select Camera dialog appears. The dialog lists all connected cameras. The version number refers to the installed Imperx GUI driver.
3. Select a camera listed on the dialog.
Camera information appears in the Device info section of the dialog.
4. Click **OK**. If needed, click **Rescan** to update the list of cameras.

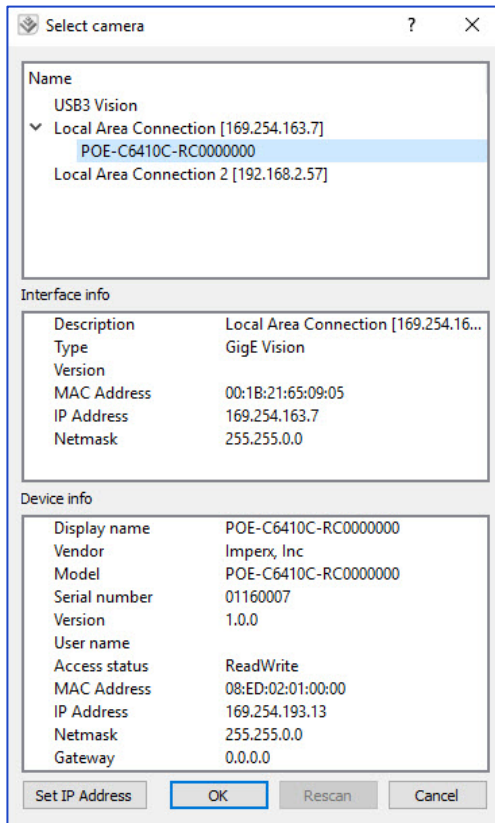

TIP ⓘ

The first time you attempt to connect to the camera, you might need to set the IP address if IP Subnet Mismatch appears highlighted in red and the OK button is not available.

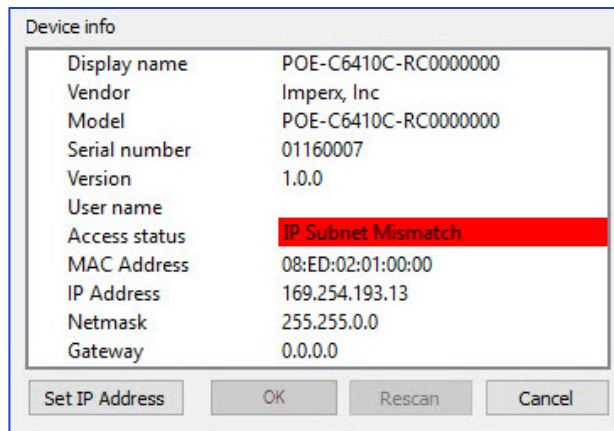
**To Set the IP Address:**

1. Click **Set IP Address**.
2. When the Set IP Address screen appears, click **OK**.
3. On the Select Camera screen, click **OK**.
If the camera is connected, the Ethernet LEDs on the camera back panel and on your Ethernet switch are blinking.

After the camera is connected, click the play  icon on the IpxPlayer to begin capturing and displaying images.



Using the IpxPlayer

The IpxPlayer displays and controls camera features and attributes based on an XML file stored in Flash memory inside the camera. The main window provides access to menus, shortcut icons, camera parameters, live images, capture options, a log, and camera statistics. You can customize the screen by closing, resizing, or hiding certain sections. Click **Log** at the bottom of the screen to see recent data transfers to or from the connected camera.









Menu Bar

The menu bar provides File, Camera, View, and Display options. Icons below the menu bar provide quick access to many of the menu bar functions. You can display an icon's function by rolling the computer cursor over it.





File Menu



Load Configuration		Opens the Open File dialog for loading a Camera Configuration file.
Save Configuration		Saves changes to an opened configuration file.
Save Configuration As		Opens the Save File dialog for saving the Camera Configuration file with a user-specified file name. Saved configurations have a file extension of <i>.iccf</i> .
Exit		Closes the application.

Camera Menu







Connect		Opens the Connection dialog for connecting to a camera.
Disconnect		Disconnects the camera.
Camera Information		Displays Camera Information including model, version, sensor type, firmware version, XML version, and so on.
Play		Starts live video.
Bandwidth testing		Allows you to find the optimal Pixel Clock value for given USB3 interface bandwidth
Stop		Stops live video.
Record		Toggles video recording start/stop on the computer's hard drive.
Snap		Captures one image and saves it to the computer's hard drive.

View Menu

GenICam Tree		Shows/hides the camera control GenICam tree panel.
Log		Shows/hides the camera control Log panel (Control, Stream, Events).
Camera Terminal		Shows/hides the Camera Terminal panel. Use this panel for uploading Firmware Updates, LUT, FFC, DPC/HPC files or downloading LUT, FFC, DPC/HPC files.
Capture		Shows/hides the Capture panel.
Statistics		Shows/hides the Statistics panel.

Inspection View		Opens a window showing a portion of the image. Use Inspection View sliders to reposition the view of your image. Drag to reposition the window.
Histogram		Shows/hides the Histogram panel.
Hex Pixel Dump		Shows/hides the Hex Pixel Dump panel. Use this panel for pixel analysis.

Display Menu

Zoom IN		Increases the zoom by 25 percent around the center of the image when clicked.
Zoom OUT		Decreases the zoom by 25 percent around the center of the image when clicked.
Actual Size (100%)		Sets zoom to 1:1 in the center of the image.
Fit to Window		Scales the image to fit within the window height while maintaining aspect ratio.
Spread to Window		Scales the image width to fit across the display window while maintaining the image aspect ratio.
Center Image		Moves the center of the image to the center of display window.

Camera Parameters Panel

The GenICam node tree displays the camera’s available configuration parameters. Use the Visibility drop-down to select an access level of Basic, Expert, or Guru.

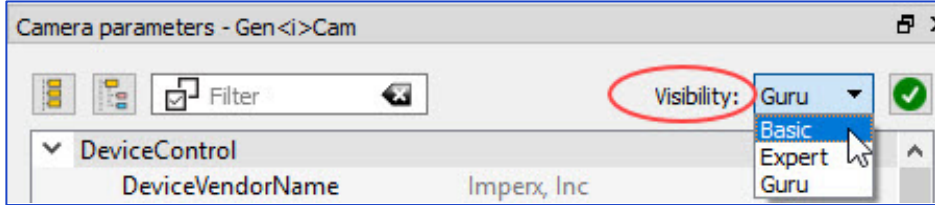

- Basic** Provides visibility of all the basic features of the camera.
- Expert** Provides visibility of advanced features of the camera that require a more in-depth knowledge of the camera functionality. This is the preferred visibility level for all advanced features in the cameras.
- Guru** Provides visibility of more advanced features that, if set incorrectly, might cause the camera to work improperly.

Device Control Category

The Device Control parameters provide information about the camera:

DeviceControl	
DeviceVendorName	Imperx, Inc
DeviceModelName	POE-C6410C-RC0000000
DeviceManufacturerInfo	Support: 1-561-989-0006
DeviceVersion	1.0.0
DeviceSerialNumber	01160007
DeviceUserID	
DeviceSFNCVersionMajor	2
DeviceSFNCVersionMinor	3
DeviceSFNCVersionSubMinor	0
DeviceReset	Execute
CameraHeadReset	Execute
DeviceTemperatureSelector	Sensor
Device Temperature	46.280000C

- DeviceVendorName** Imperx, Inc.
- DeviceModelName** Full camera part number.
- DeviceManufactureInfo** Imperx technical support: 561-989-0006
- DeviceVersion** Camera Hardware version.
- Device Serial Number** Camera serial number.
- DeviceUserID** User-defined camera name.

Device SFNC Version Major	The major version number of the GenICam Standard Features Naming Convention.
Device SFNC Version Minor	The minor version number of the GenICam Standard Features Naming Convention.
Device SFNC Version Sub Minor	The sub major version number of the GenICam Standard Features Naming Convention.
DeviceReset	Resets the entire camera, including communications.
CameraHeadReset	Resets only the image sensor to default.
DeviceTemperatureSelector	Selects the location within the camera where the temperature will be measured.
Current Temperature	Returns the current camera temperature in degrees Celsius.

Version Info Category

The camera contains non-volatile memory that stores manufacturing related information. The factory programs this information during the manufacturing process.

VersionInfo	
SensorType	Bayer
SensorModel	IMX342LQR
RgsID	4001
FpgalD	5
EpcsID	3
FirmwareImage	A
CameraHeadFirmwareVersion	10100
CameraHeadFirmwareBuild	17
CustomerID	0
FamilyID	15
XmlVersion	10303
GevFirmwareSwVersion	1031C75
GevFirmwareHwVersion	1001C75

SensorType	Returns the CMOS sensor type: Bayer Color or Monochrome
SensorModel	Returns the CMOS sensor model.
RgsID	The camera's register ID number.
FpgalD	Shows the field-programmable gate array (FPGA) ID (0=EP4C25, 1=EP4C40, 3=5CEFA4).
EpcsID	Shows the EPCS ID (0=EPCS16, 1=EPCS64, 2=EPCS128).
FirmwareImage	The Firmware Image ID (F=Factory or A=Application).
CameraHeadFirmwareVersion	The Firmware version number.
CameraHeadFirmwareBuild	The Firmware build number.

CustomerID	The Customer ID for custom firmware (0=Imperx standard firmware).
FamilyID	The Family ID.
XmlVersion	The version of the XML file.
GevFirmwareSwVersion	Displays the camera's firmware software version.
GevFirmwareHwVersion	Displays the camera's firmware hardware version.

Image Format Control Category

Provides information on the camera base resolution and output resolution.

ImageFormatControl	
WidthMax	6480
HeightMax	4860
Width	6480
Height	4860
OffsetX	0
OffsetY	0
ConstantFrameRate	true
PixelFormat	Mono8
PixelSize	Bpp8
PixelColorFilter	None
DecimationVerticalMode	Discard
DecimationVertical	1
DecimationHorizontalMode	Discard
DecimationHorizontal	1
BinningVerticalMode	Sum
BinningVertical	1
BinningHorizontalMode	Sum
BinningHorizontal	1
Polarization	<Value not available>
TestPattern	Off
SlaveAOI	

WidthMax	Maximum width of the image in pixels calculated after horizontal binning, decimation, or any other functions change horizontal dimension of image.
HeightMax	Maximum height of image in pixels calculated after vertical binning, decimation, or any other functions change vertical dimension of image.
Width	Allows you to create an AOI: sets the output image width in number of pixels (multiples of 32).
Height	Allows you to create an AOI: sets the output image height in number of lines (multiples of 8).

OffsetX	AOI Offset in horizontal dimension: Enter the number of pixels to offset the image output from the left edge of the image. The number must be a multiple of 32.
OffsetY	AOI Offset in the vertical dimension: Enter the number of pixels to offset the image output from the top of the image. The number must be a multiple of 8.
ConstantFrameRate	Allows you to enable Constant Frame Rate independent of AOI size.
PixelFormat	The number of bits of memory associated with each pixel. Options are: Mono8, Mono10, Mono10Packed, Mono12, Mono12Packed, BayerRG8, BayerRG10, BayerRG12, BayerRG10Packed, BayerRG12Packed.
PixelSize	Number of bits per pixel in memory (8-, 10-, or 12-bits).
PixelColorFilter	Shows the color filter pattern.
DecimationVerticalMode	Sets the mode to use for reducing the vertical resolution.
DecimationVertical	Sets number of rows to skip.
DecimationHorizontalMode	Sets the mode to use for reducing the horizontal resolution.
DecimationHorizontal	Sets number of columns to skip.
BinningVerticalMode	Sets the mode to use to combine rows together.
BinningVertical	Sets number of rows to combine together.
BinningHorizontalMode	Sets the mode to use to combine together.
BinningHorizontal	Sets number of columns to combine together.
TestPattern	Enables test patterns based on the following selections: BwCheckerBoard, Grey, TapSegmented, GreyHorizontalRamp, GreyVerticalRamp, HorizontalAndVerticalRamp, VerticalBars, HorizontalAndVerticalRampMoving, Crosshair, lpxGevPattern (refer to the section Test Image Pattern for more information).

Slave AOI Category

Slave AOI is disabled in POE-C2000 and POE-C2400 cameras.

▼ SlaveAOI	
SAOI_Width	6480
SAOI_Height	4860
SAOI_OffsetX	0
SAOI_OffsetY	0
SAOI_Mode	Disable

SAOI_Width	Sets a SAOI width in number of pixels (multiples of 32).
SAOI_Height	Sets a SAOI height in number of rows (multiples of 8).
SAOI_OffsetX	Sets horizontal offset in number of pixels from the beginning of each row to the Slave AOI. The number must be a multiple of 32.

SAOI_OffsetY	Sets vertical offset in number of rows from the top of the image to the Slave AOI (in pixels). The number must be a multiple of 8.
SAOI_Mode	Sets Slave AOI mode. Options are: Disable, Include, Exclude, AEC_AGC_Include, AEC_AGC_Exclude, AWB_Include, AWB_Exclude, LUT_Include, LUT_Exclude (refer to the section Slave AOI for more information on SAOI mode).

Acquisition Control Category

Acquisition Control determines the data flow between the camera and the computer.

▼ AcquisitionControl	
AcquisitionMode	Continuous
AcquisitionStart	Execute
AcquisitionStop	Execute
AcquisitionAbort	Execute
AcquisitionFrameCount	1
ExposureMode	Off
ExposureTime	<Value not available>
AcquisitionFrameRateEnable	False
AcquisitionFrameTime	300000
AcquisitionFrameRate	3.333Hz
CurrentExposureTime	272614
CurrentFrameTime	272614
CurrentFrameReadOutTimelines	4905
CurrentLineTimePClocks	2056
CurrentLineTimeUSeconds	55µs
TriggerMode	Off
TriggerSoftware	Execute
TriggerSource	Line1
TriggerActivation	RisingEdge
TriggerDebounceTime	15
TriggerOverlap	Off
TriggerType	Standard
TriggerNumFrames	1
TriggerDelay	0

AcquisitionMode	Supports three modes of acquiring images: SingleFrame, MultiFrame, and Continuous.
AcquisitionStart	Starts the acquisition of the device.
AcquisitionStop	Stops the acquisition of the device at the end of the current frame.
AcquisitionAbort	Aborts acquisition immediately, but a partially transferred image will be completed. If acquisition is not in progress, command is ignored.
AcquisitionFrameCount	Lets you enter the number of frames to acquire when using the MultiFrame Acquisition mode.

ExposureMode	Sets the operation mode of the exposure. Options are: Off, Triggerwidth, Timed (refer to the section Exposure Control for more information on exposure modes).
ExposureTime	Sets the exposure time in microseconds when Exposure Mode is set to Timed and ExposureAuto is Off.
AcquisitionFrameRateEnable:	Controls the acquisition frame rate/frame time. If this mode is On, you can extend frame time beyond the free-running frame time.
AcquisitionFrameTime	Allows you to set the actual frame time in microseconds. Changes to Acquisition Frame Time affect the Acquisition Frame Rate setting.
AcquisitionFrameRate	Allows you to set the acquisition rate (in Hz with a precision of 0.01 Hz) at which the frames are captured. Changes to Acquisition Frame Rate affect the Acquisition Frame Time setting and vice versa.
CurrentExposureTime	This is a read-only feature providing a real-time monitor of the camera exposure time in microseconds.
CurrentFrameTime	This is a read-only feature providing a real-time monitor of the camera output period in microseconds.
CurrentFrameReadOutTimeLines	Returns the current frame readout in units of sensor lines. (Number of lines readout of the sensor per frame)
CurrentLineTimePClocks	Returns the current line time in units of sensor clock cycle. Sensor clock is equal to 37.125 MHz.
CurrentLineTimeUSeconds	Returns the current line time in microseconds.
TriggerMode	Enables or disables the triggering operation. A trigger initiates an exposure then readout sequence. Triggers received prior to completion of this sequence are ignored.
TriggerSoftware	The Start SW Trigger command instructs the camera to generate one short trigger pulse to capture and read out one frame when TriggerSource is set to Software.
TriggerSource	Specifies the internal signal or physical input line used as trigger source. Options are Line1, Line2, PulseGenerator, and Software (Software is a single frame capture using internal exposure setting). Refer to the section Trigger Sources for more information on trigger sources.
TriggerActivation	Sets the triggering edge to Rising or Falling.
TriggerDebounceTime	Sets the trigger signal de-bounce time. Subsequent trigger signals coming to the camera within the de-bounce time interval are ignored.
TriggerOverlap	Sets trigger overlap mode to Off (default). If the camera receives a trigger pulse while the previous trigger is still being processed, the camera ignores this pulse.
TriggerType	Sets the trigger to Standard or Fast. Fast trigger enables exposure and readout overlap. Standard trigger sets sequential exposure and readout.

TriggerNumFrames	Sets number of frames to capture per trigger. (Available in Standard Trigger mode only).
TriggerDelay	Sets the delay time in microseconds between the trigger pulse and the start of exposure.

Gain Control Category

These parameters define analog and digital gain controls.

GainControl	
Gain	5.000000dB
BlackLevelAuto	Off
BlackLevel	0.000000
DigitalGain	1.000000x
DigitalGainRaw	1024
DigitalOffset	0
DigitalOffsetRaw	512

Gain	Sets analog/digital gain from 0 to 48 dB with 0.1 dB step.
BlackLevelAuto	Automatically adjusts the black level based on measurements of the dark reference lines at the start of each frame.
BlackLevel	This represents a DC offset applied to the video signal. Values can range from 0 to 4095.
DigitalGain	Sets digital gain from 1x to 4x.
DigitalGainRaw	Allows finer control of the <i>DigitalGain</i> . You can control the digital gain by 0.00097x per step from 1024 to 4095. Refer to section Digital Gain for more information on determining raw values.
DigitalOffset	The offset is a digital count added or subtracted from each pixel's digital value. The range is -511 to +512 counts
DigitalOffsetRaw	Controls the DigitalOffset in raw units.

Auto Gain, Exposure, and Iris Category

You can set the camera to automatic exposure control (AEC) to keep the same image brightness during changing light conditions. You can enable both AEC and automatic gain control (AGC) independently or together. Auto gain and auto exposure controls let you control the range of exposure times and gain values applied by the camera. The user can specify minimum and maximum limits on these parameters. When both AEC and AGC are enabled together, exposure times are varied until the maximum exposure time limit is reached, then gain is applied.

NOTE (✳) The POE-C2000 and POE-C2400 cameras do not support AGC and AEC.

Only POE-C1911, POE-C2010, POE-C2410, POE-C3210, POE-C4010, and POE-C4110 cameras support AIC (automatic iris control) option.

AutoGainAndAutoExposureAndAutoIris	
Control	
GainAuto	Off
AgcGainMin	0.300000dB
AgcGainMinRaw	3
AgcGainMax	48.000000dB
AgcGainMaxRaw	480
ExposureAuto	Off
AecExposureMin	500
AecExposureMax	24000
IrisAuto	Off
AicIrisMin	0
AicIrisMax	73
AgcAecAicLuminanceLevel	1024
AgcAecAicLuminanceType	Average
AgcAecAicSpeed	x4
Status	
AgcGainCurrentValue	5.000000dB
AgcGainCurrentValueRaw	50
AgcMinLimitReached	0
AgcMaxLimitReached	0
AecExposureCurrentValue	24452
AecMinLimitReached	0
AecMaxLimitReached	0
AicIrisCurrentValue	40
AicMinLimitReached	0
AicMaxLimitReached	0
CurrentAvgOrPeakLuminance	139
AgcAecAicStatus	8B032

Control Category

GainAuto	Enables automatic gain control. After selecting Continuous, the camera constantly adjusts gain to achieve the luminance target level (<i>AgcAecAicLuminanceLevel</i>). When AGC is disabled, the gain defaults to the <i>Gain</i> setting in the Gain Control Panel.
AgcGainMin	Sets the minimum gain when <i>GainAuto</i> is Continuous (step is 0.1 dB).
AgcGainMinRaw	Sets the minimum gain in RAW units.
AgcGainMax	Sets the maximum gain (up to 48 dB in 0.1 dB steps).
AgcGainMaxRaw	Sets the maximum gain in RAW units.
ExposureAuto	Enables automatic exposure control. After selecting Continuous, the camera constantly adjusts the exposure to achieve the luminance target level (<i>AecAgcAicLuminanceLevel</i>) When AEC is disabled, the exposure defaults to the Exposure settings specified in the panel.
AecExposureMin	Sets the minimum exposure time value in microseconds.
AecExposureMax	Sets the maximum exposure time value in microseconds.
IrisAuto	Enables automatic iris control. After selecting Continuous, the camera constantly adjusts the iris position to achieve the luminance target level (<i>AgcAecAicLuminanceLevel</i>). When AIC is disabled, the iris position defaults to the Iris settings specified in the P-Iris Lens Control Category .
AicIrisMin	Sets the Minimum Iris position for the AIC in steps.
AicIrisMax	Sets the Maximum Iris position for the AIC in steps.
AgcAecAicLuminanceLevel	Sets the desired luminance level to be maintained during AGC or AEC or both assuming 12-bits per pixel.
AgcAecAicLuminanceType	Sets how the luminance target is calculated in AGC or AEC. Options are Average or Peak.
AgcAecAicSpeed	Sets speed AEC/AGC tracking speed. 4x is fastest, 1x is slowest.

Status Category

AgcGainCurrentValue	Shows current status of digital gain value calculated in AGC mode in dB.
AgcGainCurrentValueRaw	Shows current status of digital gain value calculated in AGC mode in RAW units.
AgcMinLimitReached	Shows status of whether minimum digital gain limit was reached while in AGC mode.
AgcMaxLimitReached	Shows status of whether maximum digital gain limit was reached while in AGC mode.
AecExposureCurrentValue	Shows status of exposure value in microseconds, calculated by the camera in AEC mode.
AecMinLimitReached	Shows status of whether the minimum exposure limit was reached during AEC mode.

AecMaxLimitReached	Shows status of whether the maximum exposure limit was reached during AEC mode.
AicIrisCurrentValue	Displays the current position of Iris in steps.
AicMinLimitReached	Shows status of whether the minimum iris limit was reached during AIC operation.
AicMaxLimitReached	Shows status of whether the maximum iris limit was reached during AIC operation.
CurrentAvgOrPeakLuminance	Shows the current status of average or peak luminance.
AgcAecAicStatus	Internal camera use.

Data Correction Controls Category

These parameters enable data correction and image improvements with Look-up tables and file corrections.

▼ DataCorrection	
LUTEnable	Off
FFCEnable	Off
BadPixelCorrection	Off
NegativeImage	False
ReverseX	False
ReverseY	False
BitShift	NoShift

LUTEnable Selects LUT to be used in processing image (LUT1 – LUT4). LUT1 and LUT3 are pre-programmed with Gamma 0.45, LUT2 and LUT 4 are preprogrammed with negative LUT.

FFCEnable Selects FFC to be used in processing image. FFC1 has a factory preset correction. FFC2 can be created and loaded by the User.

BadPixelCorrection Provides the following correction modes: Off, Factory, and User.

NegativeImage Inverts the image from positive to negative.

ReverseX Horizontally flips the image sent by the camera. The AOI is applied after the flipping.

ReverseY Vertically flips the image sent by the camera. The AOI is applied after the flipping.

BitShift Shifts the data output bits left or right. Options are: NoShift, OneBitRight, TwoBitsRight, ThreeBitsRight, FourBitsRight, FiveBitsRight, SixBitsRight, SevenBitsRight, OneBitLeft, TwoBitsLeft, ThreeBitsLeft, FourBitsLeft, FiveBitsLeft, SixBitsLeft, SevenBitsLeft.

White Balance Category

White balance compensates for differences in the color temperature of light sources. The IpxPlayer enables color adjustments that preserve the original color so white objects appear white.

WhiteBalance	
BalanceWhiteAuto	Continuous
RedCoefficient	255
GreenCoefficient	255
BlueCoefficient	255
RedCoefficientAuto	256
GreenCoefficientAuto	256
BlueCoefficientAuto	582

BalanceWhiteAuto Selects the white balance mode with the following options: Off, Once, Continuous or Manual. In Once mode, the camera determines the red, green, and blue coefficients one time and applies them to subsequent frames. In Auto mode, the camera continuously computes the red, green, and blue coefficients to achieve good color reproduction. In manual mode, you define and manually enter the coefficients.

RedCoefficient This applies the white balance correction coefficients for Red used in manual mode. In manual mode, you enter the value. In Once or Auto modes, the camera returns the actual (calculated) coefficient. Coefficient values range from 0 to 4095.

GreenCoefficient This applies the white balance correction coefficients for Green in manual mode. In manual mode, you enter the value. In Once or Auto modes, the camera returns the actual (calculated) coefficient. Coefficient values range from 0 to 4095.

BlueCoefficient This applies the white balance correction coefficients for Blue in manual mode. In manual mode, you enter the value. In Once or Auto modes, the camera returns the actual (calculated) coefficient. Coefficient values range from 0 to 4095.

RedCoefficientAuto Displays the white balance coefficient for the Red channel (when *BalanceWhiteAuto* is Once or Continuous.

GreenCoefficientAuto Displays the white balance coefficient for the Green channel (when *BalanceWhiteAuto* is Once or Continuous.

BlueCoefficientAuto Displays the white balance coefficient for the Blue channel (when *BalanceWhiteAuto* is Once or Continuous

Strobe Category

These registers enable and control the two available strobes. Strobe signals map to one or both of the available strobe outputs. Please remember that some cameras have only one output available.

▼ Strobe	
▼ OUT1	
OUT1Polarity	ActiveHigh
OUT1Selector	Strobe1
Strobe1Mode	EachFrame
Strobe1Width	200
Strobe1Delay	20
▼ OUT2	
OUT2Polarity	ActiveHigh
OUT2Selector	None
Strobe2Mode	EachFrame
Strobe2Width	200
Strobe2Delay	20

The following descriptions apply the same to either Output 1 (OUT1) or Output 2 (OUT2) and to either Strobe1 or Strobe2.

- OUT1Polarity / OUT2Polarity** Sets the OUT1 or OUT2 active logic level to either Active Low or Active High.
- OUT1Selector / OUT2Selector** Maps the camera's internal signals to the respective Output. The signals are: ExposureStart, ExposureEnd, MidExposure, ExposureActive, HSync, VSync, OddEvenFrame, TriggerActual, TriggerDelayed, CameraReady, PulseGenerator, Strobe1, Strobe2, ToggleOut1 (refer to the section [Strobe and Synchronization Controls](#) for more information on output signals).
- Strobe1Mode / Strobe2Mode** Sets the Strobe 1 and Strobe 2 mode of operation. The options are: Off, EachFrame, OddFrame, EvenFrame.
- Strobe1Width / Strobe2Width** Sets the strobe pulse duration in microseconds.
- Strobe1Delay / Strobe2Delay** Sets the strobe delay from reference, in microseconds.

Pulse Generator Category

The Pulse Generator provides a signal generator for camera sourced trigger or control signals.

PulseGenerator	
PulseGenGranularity	x1uS
PulseGenWidth	1
PulseGenPeriod	2
PulseGenNumPulses	1
PulseGenEnable	False

PulseGenGranularity Sets the Pulse Generator main timing resolution. The x1 resolution is in microseconds. The following four granularity steps are possible: x1, x10, x100, x1000 (x1000 is equal to 1ms timing resolution).

PulseGenWidth Sets the value of the pulse width in microseconds.

PulseGenPeriod Sets the value of the pulse period in microseconds.

PulseGenNumPulses Sets the number of pulses generated by the Pulse Generator. To set Pulse Generator in continuous mode, set the parameter in 65536.

PulseGenEnable Enables the Pulse Generator.

Canon Lens Control Category

The POE-C4410, POE-C5410, POE-C6410, POE-C4410-T, POE-C5410-T, and POE-C6410-T cameras support Canon EF Active lens mount. If using Canon lens control, the following parameters are available for controlling the lens or checking its status. Please refer to the section Canon Lens Control for more information on lens adjusting procedures.

Controller Settings Pane

▼ CanonLensControl	
▼ ControllerSettings	
InitLens	Execute
StopLens	Execute
LensControllerStatus	InitLens_Done
LensAF_MF	AutoFocus
GetLensID	Execute
LensID	9126

InitLens	Initializes the Canon Lens, if one is mounted to the camera. The <i>InitLens</i> command should always be applied upon powering up.
StopLens	Removes the power from the Iris drive. Run <i>InitLens</i> command to resume the lens control.
LensControllerStatus	Shows status of Canon Lens initialization.
LensAF_MF	Shows status of Auto / manual focus switch located on the lens.
GetLensID	Request the value of the Lens ID register.
LensID	Returns the Lens ID after the <i>GetLensID</i> command is issued.

Focus Category

▼ CanonLensControl	
> ControllerSettings	
▼ Focus	
NearFull	Execute
FarFull	Execute
FocusStepValue	1
NearStep	Execute
FarStep	Execute
FocusReqPosition	0
SetFocusPosition	Execute
FocusMax	0
FocusSetMax	Execute
FocusEncoderStatus	0
GetFocusEncoderStatus	Execute
ResetFocusEncoder	Execute

NearFull	Drives the focus to the fully Near position.
FarFull	Drives the focus to the fully Far position.
FocusStepValue	Sets the focus step size for <i>NearStep</i> and <i>FarStep</i> focus. A typical step size has a value of 4.
FarStep	Drives the focus toward the Far direction based on amount defined in the <i>FocusStepValue</i> feature.
NearStep	Drives the focus toward the Near direction based on the amount defined in the <i>FocusStepValue</i> feature.
FocusReqPosition	Sets the desired focus value to use with <i>SetFocusPosition</i> command.
SetFocusPosition	Drives the focus to the absolute position defined in the <i>FocusReqPosition</i> feature.
FocusMax	Returns maximum focus encoder value.
FocusSetMax	Sets the maximum focus encoder value by copying current encoder value.
FocusEncoderStatus	Shows the current focus encoder value after issuing the <i>GetFocusEncoderStatus</i> command.
GetFocusEncoderStatus	Requests the focus encoder position value.
Reset Focus Encoder	Resets the Focus encoder.

Iris Category

▼ CanonLensControl	
> ControllerSettings	
> Focus	
▼ Iris	
IrisRequestedPositionRaw	0
SetIrisPosition	Execute
CurrentFNumber	4.55515
OpenIrisFull	Execute
CloseIrisStep	Execute
OpenIrisStep	Execute
IrisStepValue	1
GetIrisRange	Execute
IrisMin	43
IrisMax	80
IrisRange	502B2B2B

IrisRequestedPositionRaw Sets raw iris absolute position.

SetIrisPosition Drives the iris to the absolute position value of *IrisRequestedPositionRaw*.

CurrentFNumber F-number value of the lens iris. Value of 0.0 signals an unknown iris position.

OpenIrisFull Fully opens the iris.

CloseIrisStep Closes the iris based on amount entered in the *IrisStepValue* feature.

OpenIrisStep Opens the iris by the amount defined in the *IrisStepValue* feature.

IrisStepValue Sets the iris step size (between 1 and 127) when using the *OpenIrisStep* and *CloseIrisStep* commands.

GetIrisRange Determines the Iris Range. The values are read using the *GetIrisRange* command.

IrisMin Returns the minimum iris limit.

IrisMax Returns the maximum iris limit.

IrisRange Shows the limit values of the iris after issuing the *GetIrisRange* command.

P-Iris Lens Control Category

The Imperx Cheetah POE-C1911, POE-C2010, POE-C2410, POE-C3210, POE-C4010, and POE-C4110 cameras support a P-Iris (Precise Iris) lens control option. You can control the iris position manually using P-Iris Lens Control parameters.

P-Iris Lens Control	
PIrisStepValue	1
PIrisMax	73
InitialPIrisPosition	0
CurrentPIrisPosition	0
OpenPIrisStep	Execute
ClosePIrisStep	Execute
OpenPIrisFull	Execute
ClosePIrisFull	Execute

PIrisStepValue	Sets the iris step size when using the <i>OpenPIrisStep</i> and <i>ClosePIrisStep</i> commands.
PIrisMax	Sets the P-Iris maximum number of steps available. This value is unique for each model of lens. The default value is 73 (for the Kowa LM25JC5MM lens).
InitialPIrisPosition	Sets the P-Iris initial position in number of steps. Equals 0 by default (iris is Fully Open).
CurrentPIrisPosition	Returns the P-Iris current position in number of steps.
OpenPIrisStep	Opens the iris by the amount defined in the <i>PIrisStepValue</i> feature.
ClosePIrisStep	Closes the iris by the amount defined in the <i>PIrisStepValue</i> feature.
OpenPIrisFull	Opens the iris to the fully opened position.
ClosePIrisFull	Closes the iris to the fully closed position.

Transport Layer Control Category

The Transport Layer controls the exchange of data between the camera and the host computer.

▼ TransportLayerControl	
PayloadSize	31492800
▼ GigE Vision	
GevMACAddress	08:ED:02:10:02:EA
Enable Extended ID Mode	Off
GevCurrentIPConfigurationLLA	True
GevCurrentIPConfigurationDHCP	True
GevCurrentIPConfigurationPersistentIP	False
GevCurrentIPAddress	169.254.193.20
GevCurrentSubnetMask	255.255.0.0
GevCurrentDefaultGateway	0.0.0.0
GevPersistentIPAddress	0.0.0.0
GevPersistentSubnetMask	0.0.0.0
GevPersistentDefaultGateway	0.0.0.0
GevLinkSpeed	1000
GevFirstURL	LOCAL:IpXGev_CheetahPregius_1.5.9.zip;30210000;9b8c
GevSecondURL	
GevCCP	ExclusiveAccess
GevPrimaryApplicationSocket	62671
GevPrimaryApplicationIPAddress	169.254.19.34
GevMCPHostPort	62672
GevMCDA	169.254.19.34
GevMCTT	0
GevMCRC	0
GevMCSP	49152
GevSCCFGUnconditionalStreaming	False
GevSCPHostPort	0
GevSCPSFireTestPacket	Execute
GevSCPSDoNotFragment	True
GevSCPD	0
GevSCDA	0.0.0.0
GevSCSP	3011
GevSCSPPacketSize	7168
GevHeartbeatTimeout	3000
GevTimestampTickFrequency	100000000
GevTimestampControlLatch	Execute
GevTimestampControlReset	Execute
GevTimestampValue	0

PayloadSize Provides the number of bytes transferred for each image on the stream channel, including any end-of-line, end-of-frame statistics, or other stamp data.

GevMACAddress Displays the MAC address of the Ethernet network interface.

GevGVSPExtendedIDMode Sets the extended ID mode for GVSP (64 bit block_id64, 32 bit packet_id32). This bit cannot be reset if the stream channels do not support the standard ID mode.

GevCurrentIPConfigurationLLA Indicates whether a Link Local Address IP configuration scheme is activated on the network interface.

GevCurrentIPConfigurationDHCP	Indicates whether a DHCP IP configuration scheme is activated on the network interface.
GevCurrentIPConfigurationPersistentIP	Indicates whether a Persistent IP configuration scheme is activated on the network interface. A persistent IP address is hard-coded in non-volatile memory.
GevCurrentIPAddress	Displays the host computer's network IP Address.
GevCurrentSubnetMask	Displays the subnet mask of the interface.
GevCurrentDefaultGateway	Displays the default gateway IP address to be used on the network interface.
GevPersistentIPAddress	Indicates the Persistent IP address for the network interface. The persistent IP address is re-used by the camera on power-up when Persistent IP is enabled.
GevPersistentSubnetMask	Indicates the Persistent subnet mask associated with the Persistent IP address on the network interface.
GevPersistentDefaultGateway	Indicates the Persistent default gateway for the network interface.
GevLinkSpeed	Indicates the speed of transmission negotiated by network interface in Mbps.
GevCCP	Enables granting privilege to an application. Options are open access, exclusive access, or control access.
GevPrimary Application Socket	Indicates the UDP source port of the primary application.
GevPrimary Application IP Address	Indicates the address of the primary application.
GevMCPHostPort	Controls the port to which the device must send messages. Setting this value to 0 closes the message channel.
GevMCDA	Controls the destination IP address for the message channel.
GevMCTT	Provides the message channel transmission timeout value in milliseconds.
GevMCRC	Controls the number of retransmissions allowed when a message channel message times out.
GevMCSP	Indicates the source port for the message channel.
GevSCCFG UnconditionalStreaming	Enables the camera to continue to stream for this stream channel if its control channel is closed or regardless of the reception of any ICMP messages (such as destination unreachable messages).
GevSCPHostPort	Indicates the port to which the device must send data stream.
GevSCPSFireTestPacket	When this bit is set, the device will fire one test packet.
GevSCPSDoNotFragment	This bit is copied into the Do Not Fragment bit of IP header of each stream packet.
GevSCPD	Indicates the delay (in timestamp counter unit) to insert between each packet for this stream channel.

GevSCDA	Indicates the destination IP address for this stream channel.
GevSCSP	Indicates the source UDP port address for this stream channel.
GevSCFTD	Frame transmission delay in microseconds. The value of delay between the frame acquisition and transmission.
GevSCSPPacketSize	The stream packet size to send on this channel, except for data leader and data trailer, and the last data packet that might be of smaller size (since packet size is not necessarily a multiple of block size for stream channel).
GevHeartbeatTimeout	Indicates the current heartbeat timeout in milliseconds.
GevTimestampTickFrequency	This 64-bit feature indicates the number of timestamp ticks during 1 second.
GevTimestampControlLatch	Latches current timestamp counter into Timestamp Value register.
GevTimestampControlReset	Resets timestamp 64-bit counter to 0.
GevTimestampValue	Reports the latched 64-bit value of the timestamp counter

User Set Control Category

▼ UserSetControl	
UserSetSelector	Default
UserSetLoad	<Value not available>
UserSetSave	<Value not available>
UserSetDefault	Default

UserSetSelector	Points to User Configuration Set (Default, User Set 0...User Set 3) to load into the camera or save into the camera’s non-volatile memory. Default is the Factory Default Settings.
UserSetLoad	Loads the User Set specified by <i>UserSetSelector</i> into the camera workspace (volatile).
UserSetSave	Saves the User Configuration Set 0, 1, 2, or 3 specified by <i>UserSetSelector</i> to the camera’s non-volatile memory. The Default User Set is read only and cannot be modified by the user.
UserSetDefault	Points to User Configuration Set, which will be loaded and made active when the device is reset or after power is applied.

Event Control Category

▼ EventControl	
EventSelector	AcquisitionStart
EventNotification	Off

EventSelector	Selects which Event to signal to the host application.
EventNotification	Activate or deactivate the notification to the host application of the occurrence of the selected Event.

Capture Panel

The Capture panel provides options for recording images and video and saving them to the computer hard drive. Click the Capture tab at the bottom of the IpxPlayer screen to access the panel.

Recording Acquired Images

Use the Recording section of the Capture screen to record snapped images or video images. The screen displays real-time capture information during recording.

- **Snap.** Saves the current image to the hard drive.
- **Record.** Starts or stops saving video to the hard drive.
- **Statistics.** Shows the number of frames acquired, saved, and dropped during the current capture session. Dropped frames are frames received from the camera but not transferred due to a lack of host buffers.
- **Buffer Queue Filling.** Shows the current filling status of the capture frames queue.

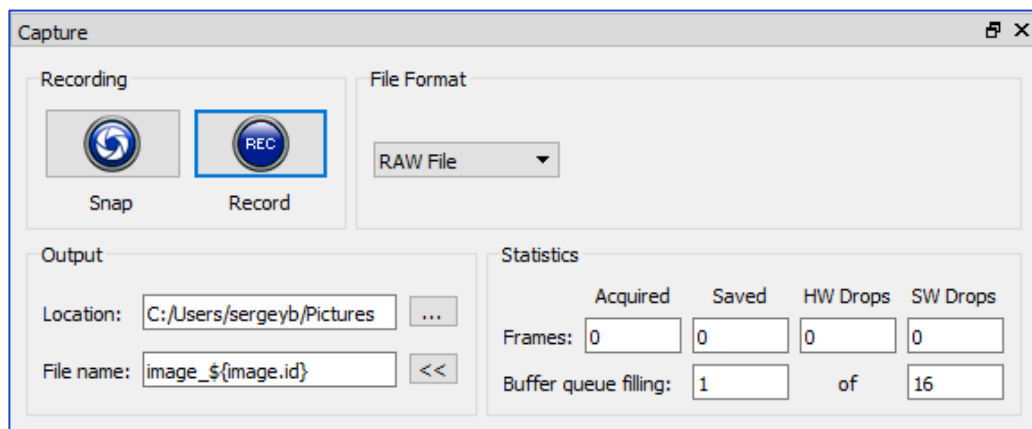

Saving Image Output

The Output and File Format sections of the Capture panel let you configure the location and format of saved images in the computer.

- **Output Location.** You determine where to save files on the computer.
- **File Name.** Defines the file name template.
- **File Format.** Allows you to specify the output file format from a drop-down list.
 - RAW File. This is an unprocessed file format.
 - BMP Image. (8-bpp BMP for grayscale, 24-bpp for Color images)
 - JPG Image. You can adjust the image quality. Default is 85%.
 - TIFF Image. Normalized option affects pixel intensity values.
 - AVI Movie. Options are – you can set the frames per second or get the current frames per second from the camera (see the [Saving Image in AVI Movie File Format](#) section).

Saving Image in AVI Movie File Format

When saving images in AVI Movie format, follow the steps below:

1. In the **File Format** drop-down list, select AVI Movie.
2. In the **Codec** drop-down list, select a compression method—MPEG 4 or Uncompressed.
3. In the **FPS** field, enter a desired value of the frame rate or click **Cam.FPS** to get the current frames per second from the camera.

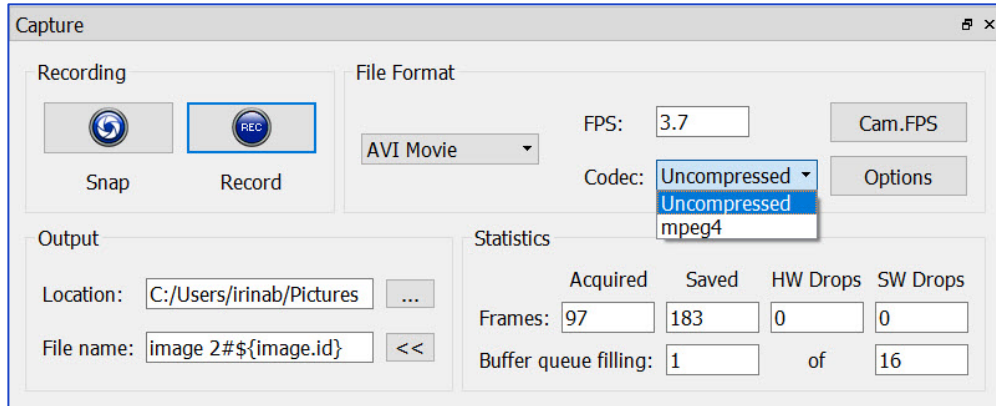

4. Click **Options**.
The Movie Options Dialog screen appears.
5. If pixel format of the images is 8-bit per pixel and the AVI file is to be viewed in Windows OS, check the **Add Palette** checkbox to add a palette to 8-bit bitmap image.

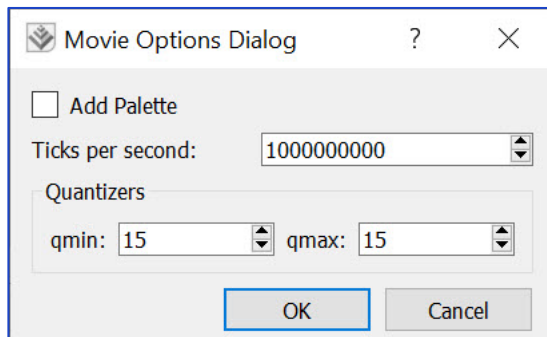

6. Make sure that a value of the **Ticks per second** parameter matches the value of the *GevTimestampTickFrequency* parameter.
7. Set minimum and maximum quantizers and click **OK**.

Log Panel

The Log panel shows data transfers to or from the connected camera. Log information provides a numeric identifier assigned by the application, the transfer time, the control channel, and the message. Click the Log tab at the bottom of the IpxPlayer screen to access the panel.

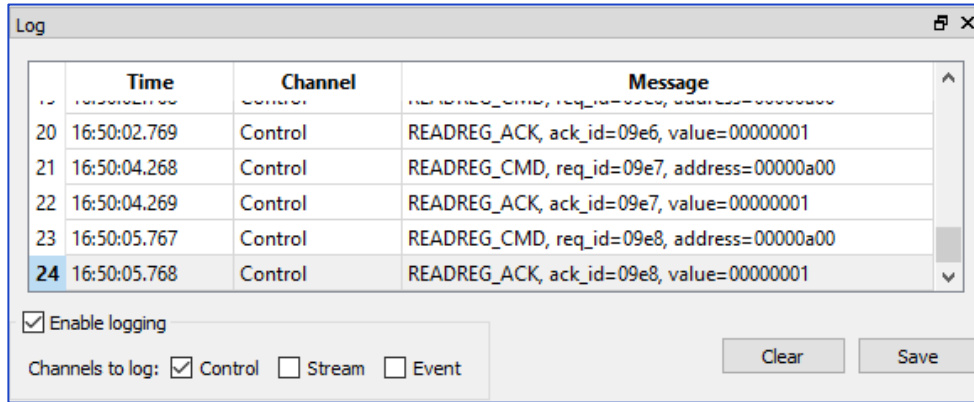

Channels to Log

The Enable Logging check box initiates logging. You can save current log data to a TXT file (.txt) with space-separated fields.

You must select a channel to log. Channels are device channels linked to an appropriate camera interface. The following options are available:

- **Control Channel.** This is a data interface linked to the camera's Device Control Channel. The Control Channel is dedicated to camera parameters control. It sends and receives the data displayed on the Camera Parameters panel. The Control Channel is bi-directional, enabling data transfers from the host computer to the camera or from the camera to the host computer.
- **Stream Channel.** This links to the camera's Device Stream Channel. The Stream Channel is dedicated to transferring video data from the camera to the host computer.
- **Event Channel.** This links to the camera's Device Event Channel. The Event Channel notifies the host computer software about any events on the camera side. For example, the camera can notify the software that it received the trigger signal.

Statistics Panel

The Statistics panel displays camera performance and other information based on settings and parameters.

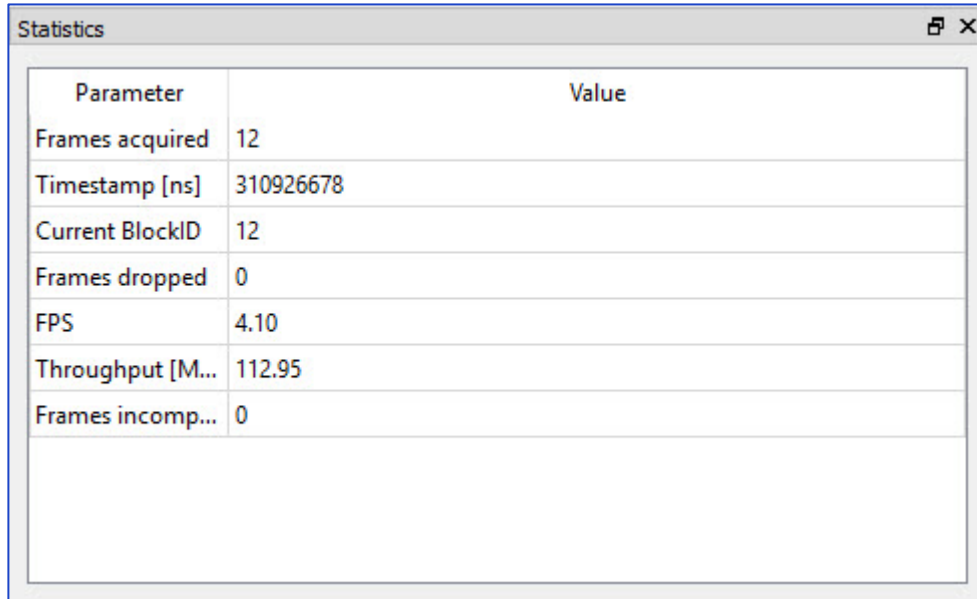

Parameter	Value
Frames acquired	12
Timestamp [ns]	310926678
Current BlockID	12
Frames dropped	0
FPS	4.10
Throughput [M...	112.95
Frames incomp...	0

Frames acquired The number of frames acquired after you click the Play button.

Timestamp [ns] The current value of the timestamp in the acquired image in nanoseconds.

Current Block ID The current value of the block ID in the acquired image.

Frames dropped The number of frames dropped by the camera (calculated from consequence block IDs).

FPS The number of frames per second.

Throughput [MB/s] The average throughput value of the camera interface in megabytes per second.

Camera Terminal Panel

The Camera Terminal panel lets you upload and download any custom files—DPM, HPM, Flat Field Correction (FFC), or Lookup Tables (LUT). It also allows you to upload Firmware updates.

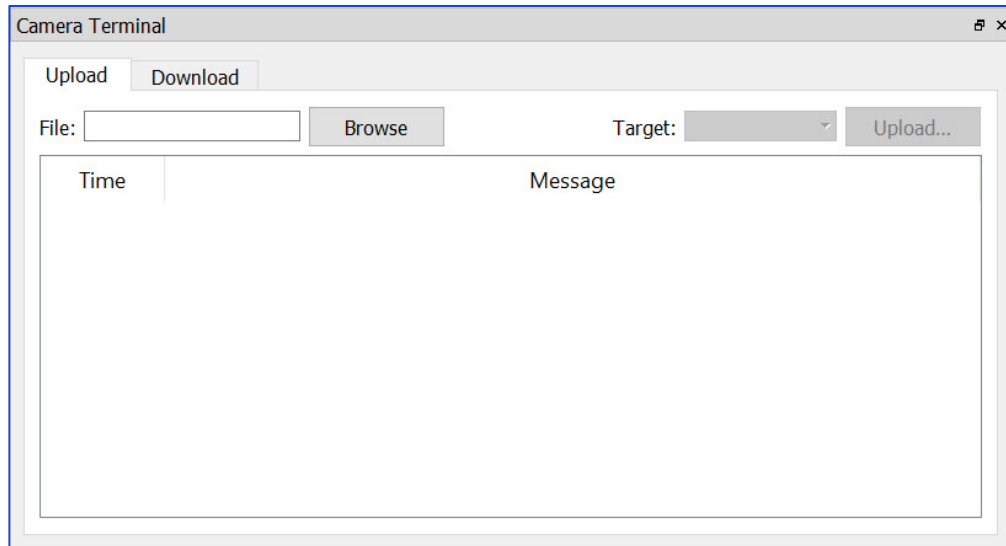

Uploading Files

To upload DPM, HPM, FFC, or LUT files from the camera, follow the steps below.

1. On the Upload tab, click **Browse** and navigate to a file (ZIP, RGS, DPM, HPM, FFC, or LUT).
2. Select the file you want to upload.
3. Select a **Target** location for the file.
4. Click **Upload...**
Reboot the camera and restart the IpxPlayer for the changes to take into effect.

Downloading Files

To download DPM, HPM, FFC, or LUT files into the camera, follow the steps below.

1. On the Download tab, select a **Location** from which to download a file.

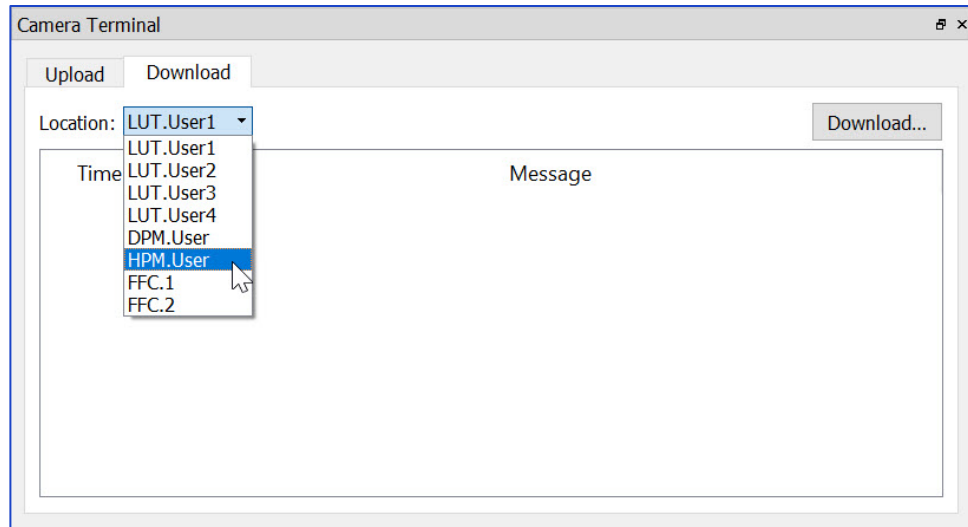

2. Click **Download...**
A readout begins.
3. Upon completing the readout, click **Save**.

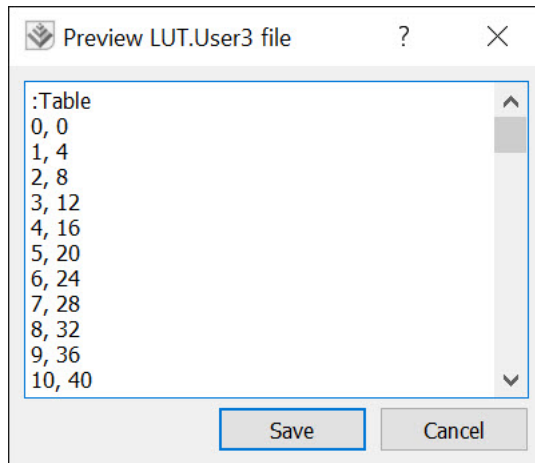

Histogram Panel

The Histogram panel shows pixel values in ADU.

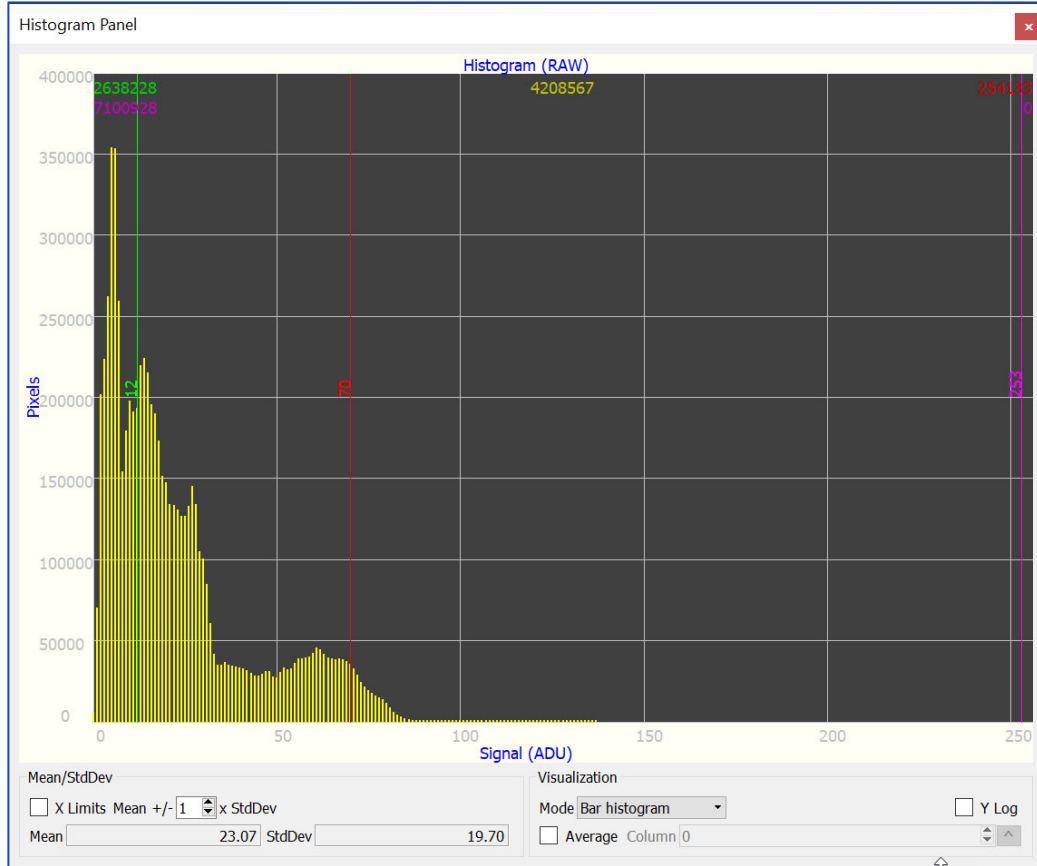

Mean/StdDev Pane

- X Limits**

Enables/disables X axis scale adjustments.
By default, the pixel values are shown within 0–255 ADU. To change the limits, check the X Limits check box and select a coefficient (1–10). The new X axis limits are:

Max. limit = Mean + StdDev x coefficient.

Min. limit = Mean – StdDev x coefficient.
- Mean**

Shows the mean pixel value (in ADU)
- StdDev**

Shows the standard deviation of pixel values (in ADU)

Visualization Pane

The Visualization pane allows you to set a histogram type and select a row or column for displaying pixel values.

Mode sets a visualization mode.

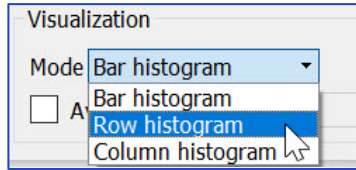

- **Bar histogram** Shows pixels' values in ADU and the number of pixels of a certain value.
- **Row histogram** Shows pixels' values in ADU in the selected row.

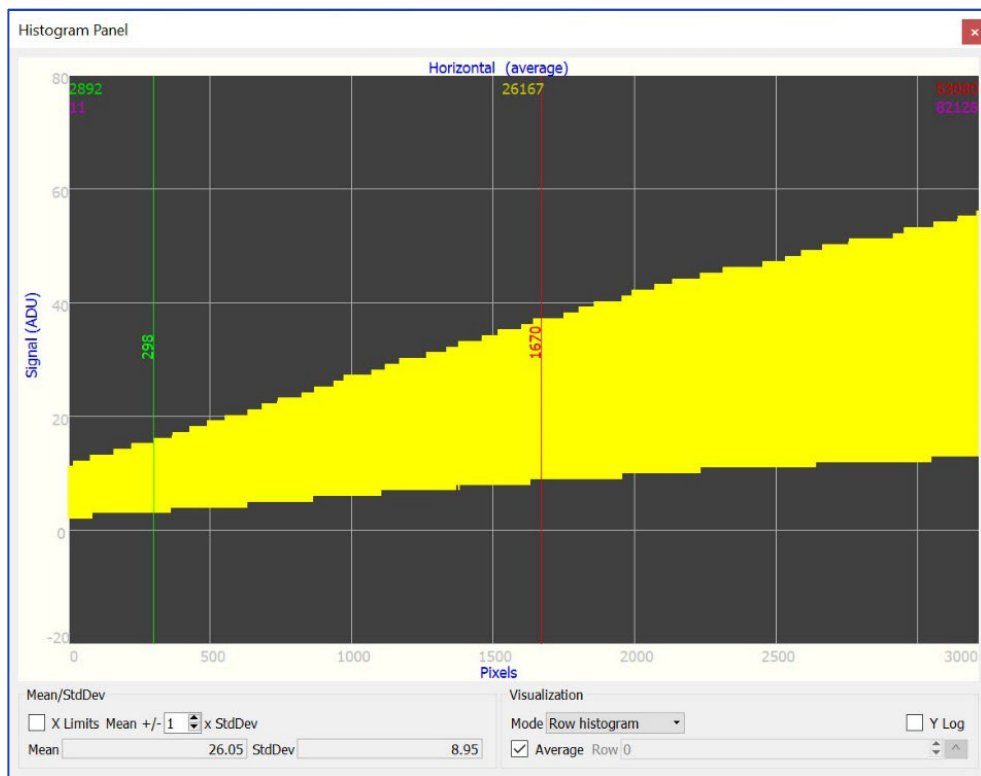

- **Column histogram** Shows pixels' values in ADU in the selected column.

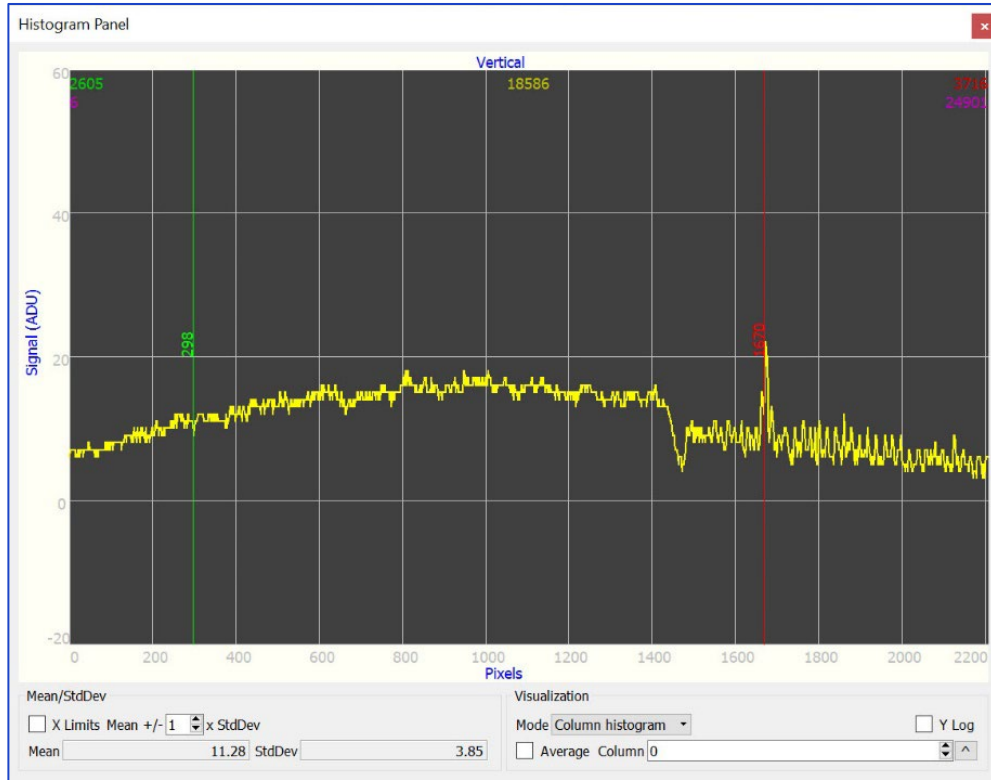

Row/Column selects a row/column coordinate to use in calculation.

Set the visualization **Mode** to **Row histogram** or **Column histogram** and select a row/column coordinate.

Average when checked, shows average pixels' values in the selected row/column.

Y Log when checked, a logarithmic Y axis is enabled.

Hex Pixel Dump Panel

The Hex Pixel Dump panel shows pixel values in the table in hex format. The active area is highlighted with a yellow frame on the display.

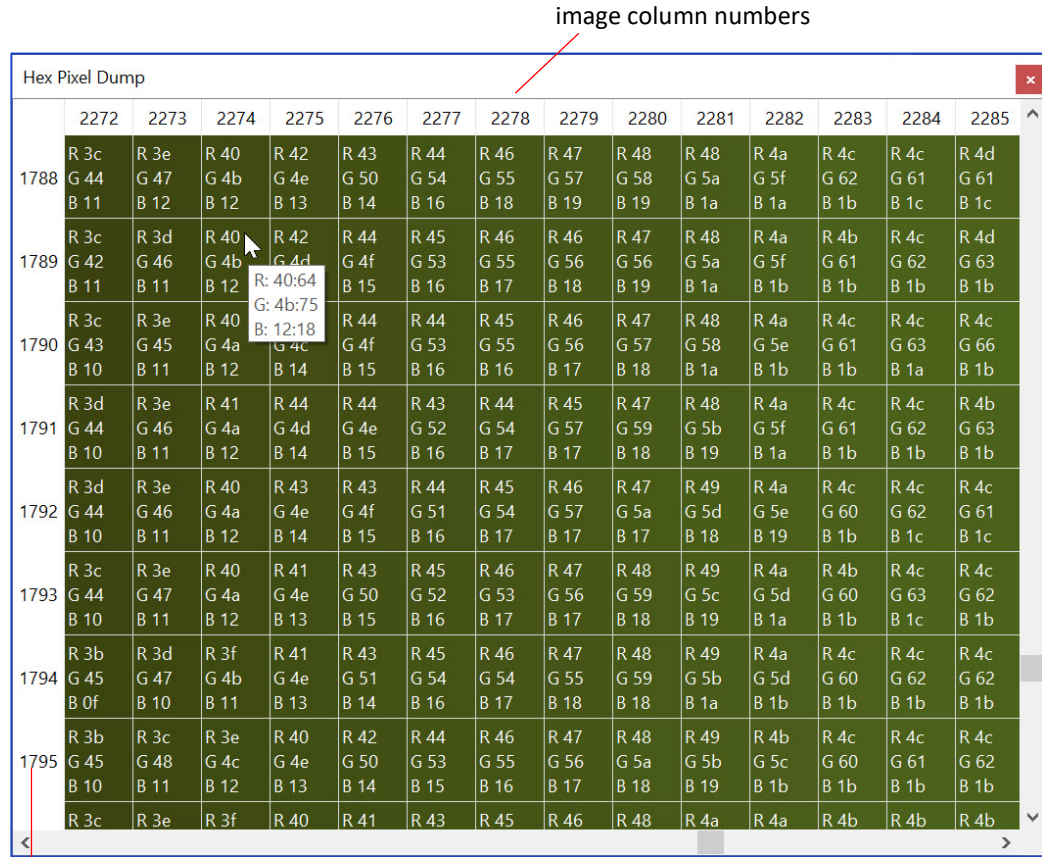
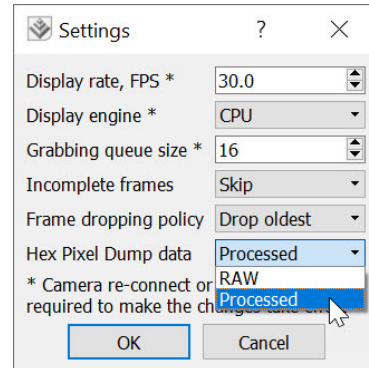

image row numbers

The pixel value is shown in RGB values for color images, and in Y (luminosity) values for monochrome image.

For the Hex pixel Dump to display the pixel values correctly, set the **Hex Pixel Dump data** parameter in the menu *File > Settings* with respect to the pixel format as shown below.

	Pixel Format	
	Packed	Unpacked
Hex Pixel Dump data	Processed	Either RAW or Processed



Camera Features

Image Data Flow

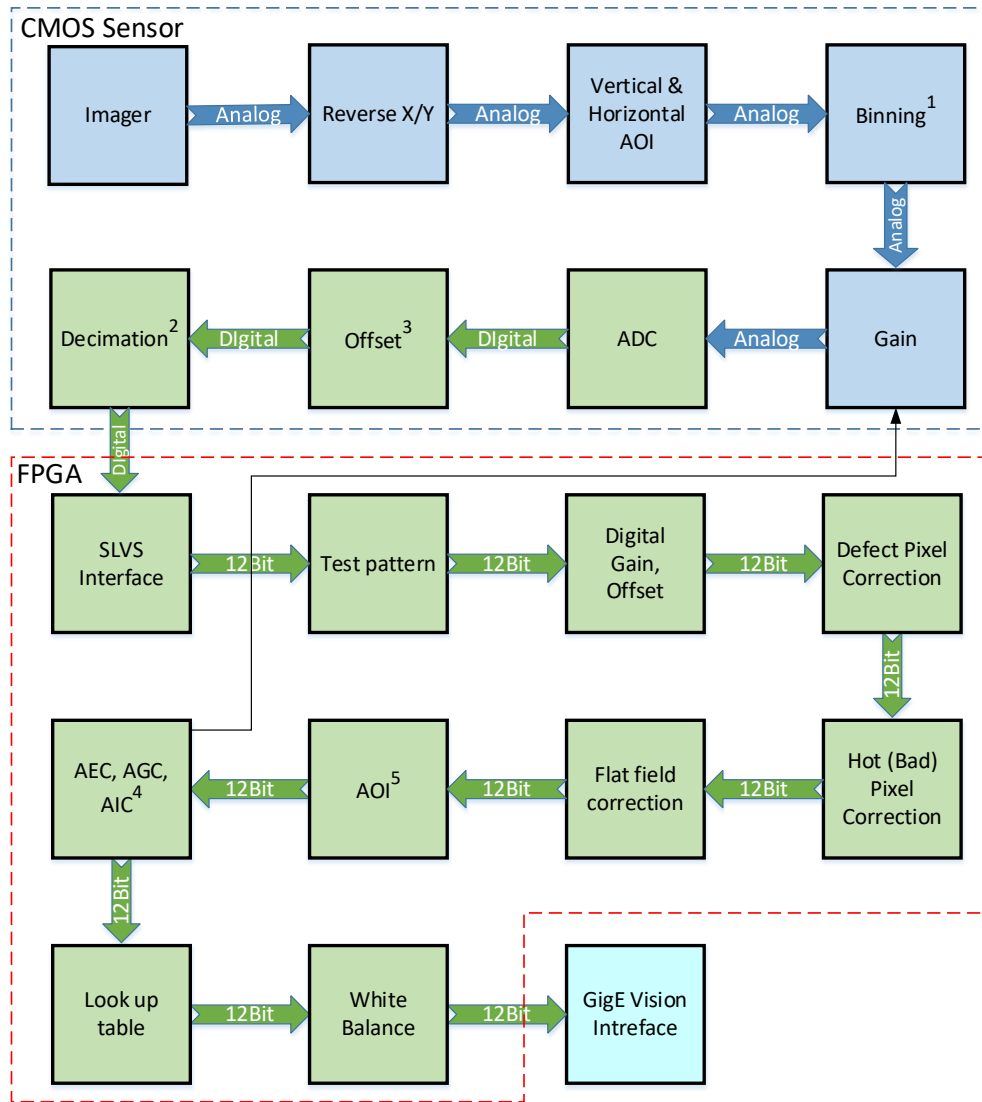

¹Binning is available in monochrome cameras only: POE-C1911, POE-C3210, POE-C4410, POE-C5410, POE-C6410, POE-C4410-T, POE-C5410-T, POE-C6410-T, P67-C1911, P67-C3210

²Sub-sampling decimation is available in all camera models except for POE-C2000 and POE-C2400

³Black Level Auto is available

⁴AEC and AGC are available in all camera models except for POE-C2000 and POE-C2400
AIC is available in POE-C1911, POE-C2010, POE-C2410, POE-C2410Y/Z, POE-C3210, POE-C4010, POE-C4110

⁵Two AOI are available in all camera models except for POE-C2000 and POE-C2400
POE-2000 and POE-C2400 do not have Slave AIO

Exposure Control

The camera provides three exposure control modes – **Off**, **Timed**, and **Trigger Width**

When exposure control is **Off**, the frame readout time determines the exposure time.

In the **Timed** mode, you can control exposure time manually or automatically. To enable manual control, set *ExposureAuto* to Off and specify the exposure time using the *ExposureTime* setting.

To enable AEC (Automatic Exposure Control), set *ExposureAuto* to Continuous. Please refer to the section [Automatic Exposure Control](#) for more information on AEC.

The camera works either in trigger (Standard or Fast Trigger) or free-running (untriggered) mode, you might need to also adjust trigger parameters when setting exposure (refer to the section [Camera Triggering](#) for more information on trigger parameters).

NOTE (★) The AEC is not available when exposure mode is set to **Trigger Width**.

Exposure Control in Free-Running Mode

Free-running mode, Exposure control is Off

Settings:

Exposure Mode: **Off**

Trigger Mode: **Off**

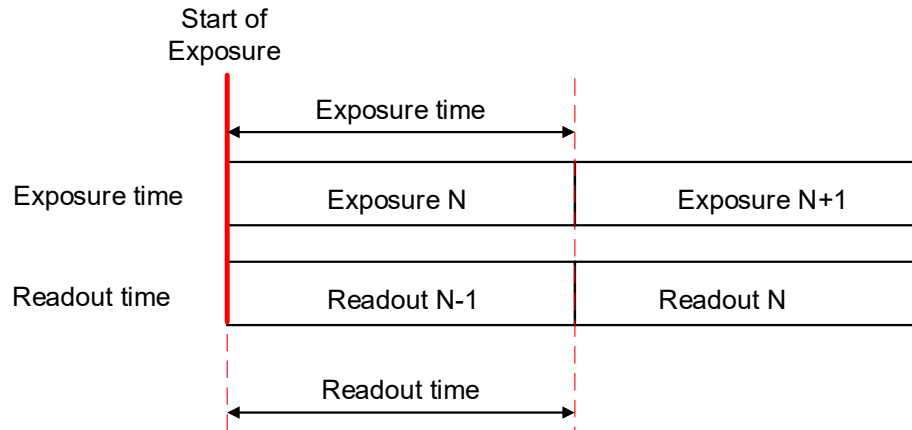

To reduce the image exposure time under bright lighting conditions, set the exposure control mode to **Timed**. The electronic exposure control does not affect the frame rate; it only changes the exposure time. When the Timed mode is active, the camera controls the start of exposure, so the new exposure ends just as the readout of the current frame ends and the readout of the next frame begins.

Free-running mode, Exposure control is Timed

Settings:

ExposureMode: **Timed**

TriggerMode: **Off**

Exposure Time: **User-specified**

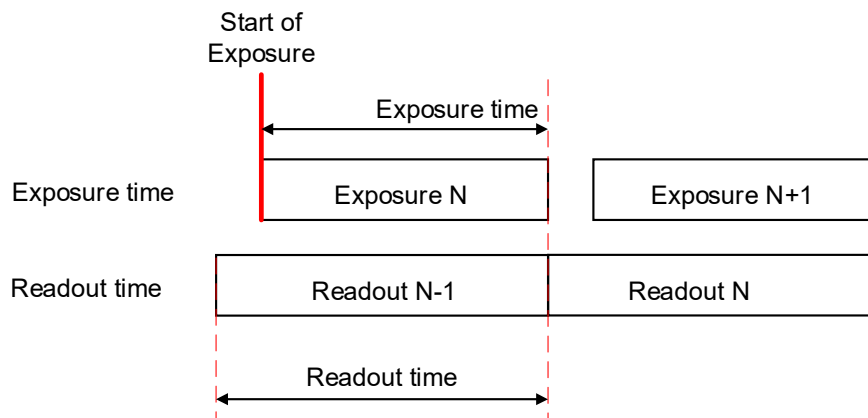

To configure the camera to work in free-running mode with Timed expose control:

1. Turn off the camera image acquisition.
2. Set *ExposureAuto* to **Off** for manual exposure control, or to **Continuous** for AEC.
3. In the Acquisition Control menu:
 - Set *TriggerMode* to **Off**.
 - Set *ExposureMode* to **Timed**.
If *ExposureAuto* is **Continuous**, *ExposureMode* turns to Timed automatically.
 - If *ExposureAuto* is **Off**, then set *ExposureTime* (in microseconds) to a user-specified value.

NOTE (*) You can extend the exposure time by increasing the frame time:

1. Check *AcquisitionFrameRateEnable* box.
2. Increase the frame time by using *AcquisitionFrameTime* (in μs) or *AcquisitionFrameRate* (in Hz) settings.
3. Set *ExposureTime* within the extended frame time range.

The camera rounds the *ExposureTime* up or down so that it is a multiple of the line time (in μs).

The maximum exposure time is defined by the formula:

$$\text{Exposure Time}_{\text{MAX}} = (T_{\text{FRAME}} - T_{\text{DELAY}}) * T_{\text{LINE}}$$

where

T_{FRAME} is a number of lines per frame (*CurrentFrameReadOutTimeLines*, in lines), depends on sensor model and camera's settings such as *PixelFormat*, AOI size, *BinningVertical*, *BinningHorizontal*, *DecimationVertical*, *DecimationHorizontal*.

T_{DELAY} is a memory wait time (in lines), depends on sensor model (see table below).

T_{LINE} is a current line time (*CurrentLineTimeUseconds* in μs), depends on sensor model and camera's settings such as *PixelFormat*, AOI size, *BinningHorizontal*, and *DecimationHorizontal*.

The maximum exposure time shown in the table below is calculated for the Cheetah cameras with the following settings:

- *ExposureMode*: Off or Timed
- *TriggerMode*: Off (Free-running mode)
- *PixelFormat*: Mono8 or BayerRG8
- Image resolution: maximum
- Binning and Sub-sampling: disabled (*BinningVertical*, *BinningHorizontal*, *DecimationVertical*, *DecimationHorizontal* are set to 1).

Camera model (POE or P67)	Sony sensor model	Max. image resolution	Memory wait time (T _{DELAY}), in lines	Lines per frame (T _{FRAME})	Line time (T _{LINE}), in μs	Max. exposure time, in μs
C1911	IMX429	1944 x 1472	4	1517	16.3	24661.9
C2000	IMX265	2064 x 1544	10	1585	17	26775
C2010	IMX265	2064 x 1544	10	1585	17	26775
C2400	IMX264	2464 x 2056	10	2097	21	43827
C2410	IMX264	2464 x 2056	10	2097	21	43827
C2410Y/Z	IMX250Y/Z	2464 x 2056	10	2097	21	43827
C3210	IMX428	3216 x 2208	12	2257	27	60615
C4010	IMX267	4112 x 2176	8	2217	35	77315
C4110	IMX304	4112 x 3008	8	3041	35	106155
C4410	IMX367	4432 x 4436	20	4481	38	169518
C5410	IMX387	5472 x 3084	16	3129	46	143198
C6410	IMX342	6480 x 4860	14	4905	55	269005

The minimum exposure time in free-running and Fast trigger modes is determined by the formula:

$$\text{Exposure Time}_{\text{MIN}} = T_{\text{OFFSET}} + T_{\text{LINE}}$$

where

T_{OFFSET} is an exposure time error (in μs), depends on sensor model (see table below).

T_{LINE} is a current line time (*CurrentLineTimeUSeconds*, in μs), depends on sensor model and camera's settings such as *PixelFormat*, AOI size, *BinningHorizontal*, and *DecimationHorizontal*.

The minimum exposure time shown in the table below is calculated for the Cheetah cameras with the following settings:

- *ExposureMode*: Off or Timed
- *TriggerMode*: Off (Free-running mode) or Fast
- *PixelSize*: Mono8 or Bayer
- Image resolution: maximum
- Binning and Sub-sampling: disabled (*BinningVertical*, *BinningHorizontal*, *DecimationVertical*, *DecimationHorizontal* are set to 1).

Camera model (POE or P67)	Sony sensor model	Max. image resolution	Exposure time error (T_{OFFSET}), in μs	Line time (T_{LINE}), in μs	Min. exposure time, in μs
C1911	IMX429	1944 x 1472	5	16.3	21.3
C2000	IMX265	2064 x 1544	14	17	31
C2010	IMX265	2064 x 1544	14	17	31
C2400	IMX264	2464 x 2056	14	21	35
C2410	IMX264	2464 x 2056	14	21	35
C2410Y/Z	IMX250Y/Z	2464 x 2056	14	21	35
C3210	IMX428	3216 x 2208	5	27	32
C4010	IMX267	4112 x 2176	14	35	49
C4110	IMX304	4112 x 3008	14	35	49
C4410	IMX367	4432 x 4436	30	38	68
C5410	IMX387	5472 x 3084	30	46	76
C6410	IMX342	6480 x 4860	30	55	85

Exposure Control in Trigger Mode

In Trigger mode, you can synchronize the exposure start and duration to an external signal. Two exposure control options are available: Timed or Trigger Width. Trigger mode can be set to either Standard or Fast (see [Camera Triggering](#)).

NOTE (★) The electronic exposure control does not affect the camera's frame rate in Fast trigger mode, because the exposure and readout operations are overlapped in time.

In Standard Trigger mode, the maximum frame rate depends upon the exposure time, because the exposure and readout occur sequentially (not overlapped).

In **Timed** exposure mode, the external trigger pulse controls the start of exposure. The exposure duration can be controlled manually or automatically (AEC).

To configure the camera to work in **Timed** exposure mode:

1. Turn off the camera image acquisition.
2. Set *ExposureAuto* to **Off** for manual exposure control, or to **Continuous** for AEC.
3. In the Acquisition Control menu:
 - Make sure that *AcquisitionFrameRateEnable* is False.
 - Set *TriggerMode* to **On**.
 - Set *ExposureMode* to **Timed**.
If *ExposureAuto* is **Continuous**, *ExposureMode* turns to Timed automatically.
 - If *ExposureAuto* is **Off**, then set *ExposureTime* (in μs) to a user-specified value.

NOTE (★) The camera rounds the *ExposureTime* up or down so that it is a multiple of the line-time (in μs).

4. Configure the trigger parameters.
Please refer to the section [Configuring the Trigger](#), steps 4–9.

In **Trigger Width** mode, the external trigger signal controls the start and duration of the exposure. This mode is available in both Standard and Fast trigger modes (refer to the sections [Standard Trigger Mode](#) and [Fast Trigger Mode](#)).

To configure the camera to work in **Trigger Width** exposure mode:

1. Turn off the camera image acquisition.
2. Make sure that *ExposureAuto* is **Off** and *AcquisitionFrameRateEnable* is False.
3. In the Acquisition Control menu:
 - Set *TriggerMode* to **On**.
 - Set *ExposureMode* to **TriggerWidth**.
4. Configure the trigger pulse parameters.
Please refer to the section [Configuring the Trigger](#), steps 4–9.

NOTE ⚠ In Standard Trigger mode, the maximum exposure time is defined by the formula:

$$ExposureTime_{MAX} = Trigger\ Period - Readout\ Time,$$

where the Readout Time is equal to the *CurrentFrameReadOutTimeLines* multiplied by *CurrentLineTimeUSecnds* (see the example below).
If exposure time exceeds the *Exposure Time_{MAX}*, the camera skips the next trigger signal and loses frames.

If AEC is enabled, make sure that the maximum exposure time is within the limit: $AecExposureMax \leq Trigger\ Period - Readout\ Time$ (see the example below).

In **Standard** trigger mode, the minimum exposure is equal to 1 line time. This value depends on a sensor model and some other parameters such as *PixelFormat*. In **Fast** trigger mode, the maximum exposure time is 16 s.

EXAMPLE

POE-C6410 camera
 PixelFormat: 8 bpp
 Image Resolution: 6480x4860 (max)
 CurrentFrameReadOutTimeLines: 4905
 CurrentLineTimeUSecnds: 55 μs
 Trigger period: 1 s (or 1,000,000 μs)

AcquisitionControl	
AcquisitionMode	Continuous
AcquisitionStart	Execute
AcquisitionStop	Execute
AcquisitionAbort	Execute
AcquisitionFrameCount	1
ExposureMode	Timed
ExposureTime	82572μs
AcquisitionFrameRateEnable	<Value not available>
AcquisitionFrameTime	<Value not available>
AcquisitionFrameRate	<Value not available>
CurrentExposureTime	29
CurrentFrameTime	16777215
CurrentFrameReadOutTimeLines	4905
CurrentLineTimePClocks	2056
CurrentLineTimeUSecnds	55μs

Readout time = 4095*55 μs = 225,225 μs
 Exposure Time_{MAX} = 1,000,000 μs - 225,225 μs = 774,775 μs
 AecExposureMax ≤ 774,775 μs

Global Shutter

In global shutter mode, all pixels in the array reset at the same time, then collect signal during the exposure time, and finally transfer the image to a pixel memory region within each pixel. After transferring the image to the pixel memory region, the readout of the array begins. In this way, all pixels capture the image during the same period, which reduces any image artifacts due to motion within the scene. The maximum exposure is frame-time dependent, and the minimum exposure varies based on the image sensor.

The camera overlaps the exposure and read-out times in free-running and Fast trigger modes as shown in the following figure.

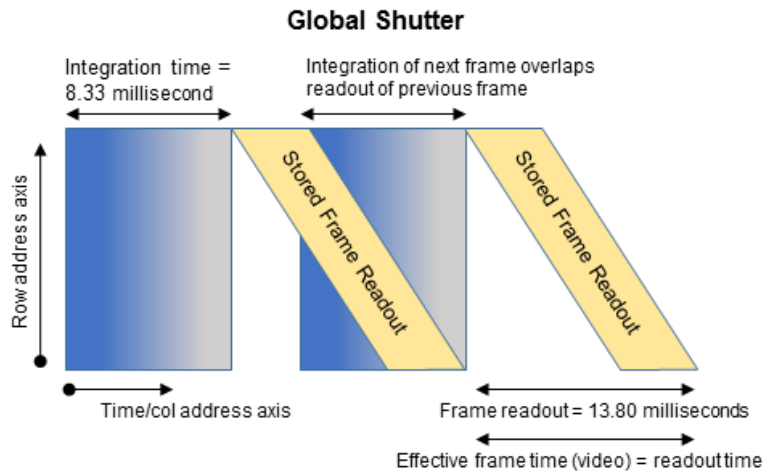

Automatic Exposure Control

You can set the camera to automatic exposure control (AEC) to keep the same image brightness during changing light conditions. You can enable both AEC and automatic gain control (AGC) independently or together.

In AEC mode, you can set the image luminance (brightness) target, and the camera adjusts the exposure accordingly. The luminance target is a 12-bit value. To determine the luminance target when using 8-bits per pixel, take the desired output in ADUs and multiply this value by 16. You can select the target luminance to be either the average luminance or peak luminance within the image.

The camera adjusts the exposure starting within the preset limit established by the user-specified minimum/maximum limits. When AEC and AGC are enabled, exposure is always varied first until the exposure reaches the maximum limit. The camera then indicates the exposure maximum limit has been reached and begins increasing the gain until either the luminance target is achieved or the maximum gain limit is reached.

You can preset the speed of convergence (how fast the camera stabilizes after an illumination change) using four possible rates. Slower convergence rates are more stable than faster convergence rates, if the illumination levels change quickly over a wide intensity range. The camera displays the current luminance, current exposure, and current gain. For auto gain control, refer to [Automatic Gain Control](#).

CAUTION

In some rapidly changing and bright light conditions, an image brightness oscillation (image intensity flipping from bright to dark) could occur. To prevent this, increase the AEC minimum exposure setting, decrease the convergence speed, and/or decrease the lens iris.

NOTE  The POE-C2000 and POE-C2400 cameras do not support AEC.

Automatic Gain Control

Automatic gain control (AGC) enables the camera to maintain the same image brightness during changing light conditions. In AGC mode, you can set the image luminance (brightness), and the camera will adjust the gain accordingly. Luminance options are average or peak.

The camera starts by changing the gain within the specified min-max limits.

- If reaching one of the gain limits, the camera indicates the limit has been reached and maintains this value until the light condition change. You can set the speed of convergence from four possible options.
- If enabling AEC mode and AGC mode together, the camera starts by changing the exposure first within the specified min-max limits until the maximum exposure limit is reached.
- Upon reaching the maximum exposure limit, the camera adds gain and changes it within the specified min-max limits.

The AEC/AGC algorithm samples all pixels for the entire frame. The camera displays the current luminance within the frame, the current exposure, and the current gain.

NOTE (*) The POE-C2000 and POE-C2400 cameras do not support AGC.

Automatic Iris Control

A P-Iris lens uses a stepper motor for adjusting an iris position. You can control the iris position manually or let the camera adjust the iris by enabling Automatic Iris Control (AIC).

NOTE ⚠ Only Cheetah POE-C1911, POE-C2010, POE-C2410, POE-C3210, POE-C4010, and POE-C4110 cameras support the P-Iris (Precise Iris) lens control option.

Automatic Iris Control (AIC) enables the camera to maintain the same image brightness during changing lighting conditions. In AIC mode, you can set the image luminance (brightness), and the camera will adjust the iris accordingly. Luminance options are Average or Peak.

The camera starts by changing the iris within the specified min-max limits.

If one of the iris limits is reached, the camera indicates the limit has been reached and maintains this value until the lighting conditions change.

You can set the speed of convergence (how fast the camera stabilizes after an illumination change) using four possible rates. Slower convergence rates are more stable than faster convergence rates, if the illumination levels change quickly over a wide intensity range.

 **CAUTION**

In some rapidly changing and bright light conditions, an image brightness oscillation (image intensity flipping from bright to dark) could occur. To prevent this, increase the AIC minimum iris position (*AicIrisMin*), decrease the convergence speed (*AgcAecAicSpeed*), decrease the gain and/or increase the minimum exposure.

You can enable AIC, AEC (Automatic Exposure Control), and AGC (Automatic Gain Control) independently or together by setting them to the *Continuous* mode. With all three controls enabled together, the camera provides the best image quality by adjusting the iris, gain, and exposure.

The AIC controls the amount of light passing through a lens by changing the iris opening. The AGC affects the maximum signal-to-noise ratio (SNR) by adjusting the amplification of a video signal. Increasing gain reduces the maximum SNR. The AEC controls both the amount of light captured by the image sensor and the SNR by adjusting the time an electronic shutter stays open. Generally speaking, longer exposure times equate to improved SNR and the maximum exposure limit value should be as high as possible without introducing motion smear in the image.

When enabling AIC, AEC, or AGC, you need to specify the minimum and maximum limits of the iris position, exposure, and gain. The camera uses the gain and exposure limits to determine the initial conditions for the AEC and AGC algorithms. Otherwise, the camera applies the default ones.

Default limits	Value	Description
Gain limits		
<i>AgcGainMin</i>	0 dB	
<i>AgcGainMax</i>	48 dB	
Exposure limits		
<i>AecExposureMin</i>	Varies	Depends on camera model.
<i>AecExposureMax</i>	Varies	Depends on current frame time.
Iris limits		
<i>AiclrisMin</i>	0 steps	The iris is Fully Open (max. aperture).
<i>AiclrisMax</i>	73 steps	The iris is Fully Closed (min. aperture). The maximum possible value equals to the <i>PlrisMax</i> parameter and depends on a lens model. You may need to adjust <i>PlrisMax</i> if the maximum number of steps of your P-Iris lens differs from 73 (73 is pre-set value for the Kowa LM25JC5MM lens in default (factory) configuration). Please refer to the documentation on your P-Iris lens for this parameter or contact a lens distributor for more information.

The initial conditions for the AEC, AGC, and AIC algorithms when first activated are:

- the exposure is always set to the value:

$$\text{Exposure} = \text{AecExposureMin} + \frac{\text{AecExposureMax} - \text{AecExposureMin}}{2}$$

- the gain is always set to the minimum limit determined by *AgcGainMin* (0 by default)
- the iris is in *CurrentPlrisPosition*

If AIC, AEC, and AGC modes are enabled together, the camera starts by changing the iris position first. Depending on initial lighting conditions, the camera applies AIC, AEC, and AGC algorithms according to either Case 1 or Case 2 shown below.

CASE 1

When the Current image luminance **is lower than the** Target image luminance, the camera expands the iris opening allowing more light through the lens. When the iris is Fully Open (*AiclrisMin* is reached), the camera indicates the minimum limit (in steps) has been reached. (The iris is Fully Open when the current iris position (in steps) is minimum.) The camera then increases the exposure until the exposure reaches the maximum limit. The camera indicates the exposure maximum limit has been reached and increases the gain until either the target image luminance is achieved, or the maximum gain limit is reached.

The camera maintains these values until the lighting conditions change and starts by decreasing the gain first to decrease the image luminosity. If the gain minimum limit is reached, the camera decreases the exposure until it reaches the minimum limit. The camera then indicates the exposure minimum limit has been reached and closes the iris until either the target luminosity is achieved, or the iris is Fully Closed (*AiclrisMax* is reached).

CASE 2

When the Current image luminance **is higher than the** Target image luminance, the camera contracts the iris opening allowing less light through the lens. When the iris is Fully Closed (*AicIrisMax* is reached), the camera indicates the maximum limit has been reached. (The iris is Fully Closed when current P-Iris position (in steps) is maximum.) The camera then decreases the exposure until either the luminance target is achieved, or the minimum exposure limit is reached.

The camera maintains these values until the lighting conditions change. The camera then follows the algorithm described in **Case 1** to increase the image luminance starting with iris adjustments to increase image luminance.

NOTE * The size of an iris opening (aperture) affects a depth of field (DOF). The larger the aperture, the blurrier the background and foreground of an image. The smaller the aperture, the sharper the image.

A long exposure causes a blurring effect when capturing fast-moving objects.

The AIC/AEC/AGC algorithm samples all pixels for the entire frame. The camera displays the current luminance within the frame, the current exposure, the current gain, and the current iris position

Acquisition Control

You can control acquisition by selecting mode, number of frames to capture, acquisition frame time and frame rate. You can extend the actual frame time beyond the free-running frame time up to 16 s.

Acquisition Control mode	Description
SingleFrame	acquires one image during the acquisition period
MultiFrame	acquires a specified number of images during the acquisition period
Continuous	acquires images continuously

Gain and Offset

Image Sensor’s Analog and Digital Gain

The image sensor allows you to apply up to 48 dB of gain to the image prior to A/D conversion. The first 24 dB of gain is analog gain and some improvement in noise performance may result. The camera applies the last 24 dB of gain digitally, which affects both signal and noise equally.

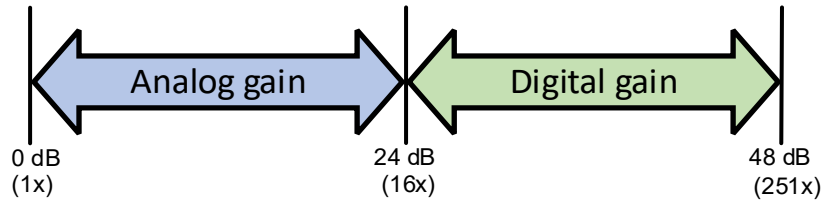

Digital Gain

Digital gain is applied after A/D conversion. Digital gain can be varied from 1x (0 dB) to 4x (12 dB) with a precision of ~0.00097x using the raw (fine) gain control. There are 3,092 gain steps from 1x gain to 4x gain. Each step increases the gain by 0.000969932x or 1/1031 from 1024 (1.0x gain) to 4095 (4x gain). Digital gain does not provide any improved contrast and should be used cautiously.

To determine the gain step when the gain value is known, use the following steps:

1. Subtract 1.0 from the desired gain multiplier (e.g. 2.5x gain).
2. Multiply the result by 1031.
3. Add 1024.

Or use this formula:

$$\text{Gain coefficient} = [(\text{Desired gain} - 1) * 1031] + 1024.$$

If the desired gain is in dB, use the following formula:

$$\text{Gain coefficient} = [([\text{anti-log}_{10}(\text{Desired gain (dB)}/20)] - 1) * 1031] + 1024.$$

EXAMPLES:

1) Desired gain is 2.5x: $[(2.5 - 1.0) * 1031] + 1024 = 2570$.

Set coefficient to 2570.

2) Desired gain is 6 dB, then the code is 2050.

Minimum setting is 1024 corresponding to 1x gain. Below are other examples:

Gain (dB)	Multiplier	Coefficient
0 dB	1x	1024
3 dB	1.41254x	1449
6 dB	1.99526x	2050
12 dB	3.98107x	4097

Digital Offset

Digital offset is a digital count added or subtracted from each pixel. The range is - 512 to +511 counts.

Black Level Auto-Calibration and Offset

The camera automatically adjusts black level based on measurements of the dark reference lines at the start of each frame. Imperx recommends leaving the *BlackLevelAuto* engaged (continuous).

Black level auto-calibration does not work properly at the changing temperature. The black level shifts from the reference level. Disable the *BlackLevelAuto* and adjust the *BlackLevel* manually from 0 to 4095 counts. Recommended value is 240. Black level will vary with temperature and gain.

Data Output Format

The image sensor digitization level is fixed at 12-bits, which enables 8-bit, 10-bit or 12-bit data format output. With 8-bit output, the camera uses the standard bit reduction process and truncates the least significant bits.

12-bit digitization

- If the camera is set to output 12-bit data, sensor data bits map directly to D0 (LSB) to D11 (MSB).
- If the camera is set to output 10-bit data, sensor most significant data bits (P2 to P11) map to D0 (LSB) to D9 (MSB)
- If the camera is set to output 8-bit data, sensor most significant data bits (P4 to P11) map to D0 (LSB) to D7 (MSB).

MSB		Camera Output – 12 bits								LSB	
D11	D10	D9	D8	D7	D6	D5	D4	D3	D2	D1	D0
P11	P10	P9	P8	P7	P6	P5	P4	P3	P2	P1	P0

MSB		Camera Output – 10 bits								LSB	
D9	D8	D7	D6	D5	D4	D3	D2	D1	D0	-	-
P11	P10	P9	P8	P7	P6	P5	P4	P3	P2	P1	P0

MSB		Camera Output – 8 bits						LSB			
D7	D6	D5	D4	D3	D2	D1	D0	-	-	-	-
P11	P10	P9	P8	P7	P6	P5	P4	P3	P2	P1	P0

Pulse Generator

The camera has a built-in pulse generator that you can program to generate a discrete sequence of pulses or a continuous sequence. You can use the pulse generator as a trigger signal or map it to one of the outputs. Set the discrete number of pulses from 1 to 65535 with a step of 1.

You can also set the following options:

- **Granularity** – Indicates the number of clock cycles used for each increment of the width and the period. Four possible options are available: x1, x10, x100, and x 1000.
- **Width** – Specifies the amount of time (determined by the granularity) the pulse remains at a high level before falling to a low level.
- **Period** – Indicates the amount of time (also determined by the granularity) between consecutive pulses.

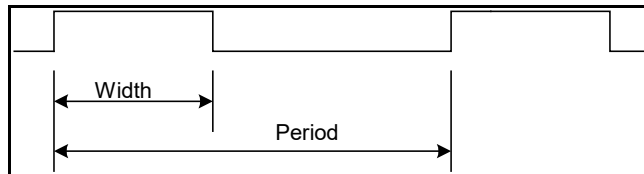

Input / Output Control

Some camera models support two inputs and two outputs (one TTL and one opto-isolated output), others may have only one input and one output (both opto-isolated).

Camera model	Inputs				Outputs			
	Opto-isolated		TTL/LVTTL		Opto-isolated		TTL	
	Name	Pin#	Name	Pin#	Name	Pin#	Name	Pin#
POE-C2000, POE-C2400	IN1	2	N/A	N/A	OUT1	4	N/A	N/A
	IN1 RTN	3			OUT1 RTN	5		
P67-C1911, P67-C2010, P67-C2410, P67-C3210, P67-C4010, P67-C4110	IN1	3	N/A	N/A	OUT1	6	OUT2	8
	IN1 RTN	4			OUT1 RTN	4	OUT2 RTN	5
POE-C1911 POE-C2010, POE-C2410, POE-C3210, POE-C4010, POE-C4110, POE-C4410, POE-C5410, POE-C6410, POE-C4410-T, POE-C5410-T, POE-C6410-T	IN1	8	IN2	9	OUT2	5	OUT1	7
	IN1 RTN	10	IN2 RTN	11	OUT2 RTN	12	OUT1 RTN	6

You can map Input 1 or Input 2 to the camera trigger source by following steps 1–9 in the section [Configuring the Trigger](#). In Step 5, set *TriggerSource* to **Line1** (Input 1) or **Line 2** (Input 2) respectively.

The inputs have debounce option to prevent false triggering. The debounce option defines the time period following a triggering event in which no additional triggers will be accepted by the camera.

You can map up to fourteen signals to either Output 1 or Output 2 by setting *OutputSelector* parameter to one of them (refer to the section [Strobe and Synchronization Controls](#)). For each mapped signal you can select active High or active Low.

If applicable, enable a strobe and specify its width and delay (for more information, refer to the section [Configuring the Strobe](#)).

Camera Triggering

Use the **Trigger Mode** control to synchronize the camera to an external event and acquire an image at a specific time. A trigger pulse is issued when the external event occurs. The camera then receives the trigger and acquires the images.

The camera supports Standard and Fast Trigger modes.

Standard Trigger Mode

In **Standard trigger mode**, the camera first performs the exposure (using the internal timer or external pulse width) and then reads out the image. The minimum trigger period is equal to the maximum exposure time plus the camera readout time.

You can set the number of frames to acquire for each trigger using *TriggerNumFrames* setting. By default, *TriggerNumFrames* is equal to 1 frame. The maximum number of frames is 65535.

NOTE ⚠ The *TriggerNumFrames* setting is available in Standard trigger mode with *ExposureMode* set to Timed only.

An external timing pulse controls the start of the exposure when *ExposureMode* is set to Timed.

Standard trigger mode, Exposure control is Timed

GenICam controls

TriggerMode: **On**
 TriggerType: **Standard**
 TriggerSource: **Line 1** (or Line2, Software, Pulse Generator)
 TriggerActivation: **Rising Edge** (or Falling Edge)
 TriggerDelay, TriggerDebounceTime: – **set if applicable.**
 Exposure Mode: **Timed**
For manual exposure control:
 Exposure Time: **User-specified** (Min. = 1 line time, camera-dependent;
 Max = Trigger period - Readout time)
 ExposureAuto: **Off**
For automatic exposure control (AEC):
 ExposureAuto: **Continuous**

Parameters of the external trigger pulse

Trigger width: $\geq 10 \mu s$
 Trigger period (min) = Exposure time + Readout time

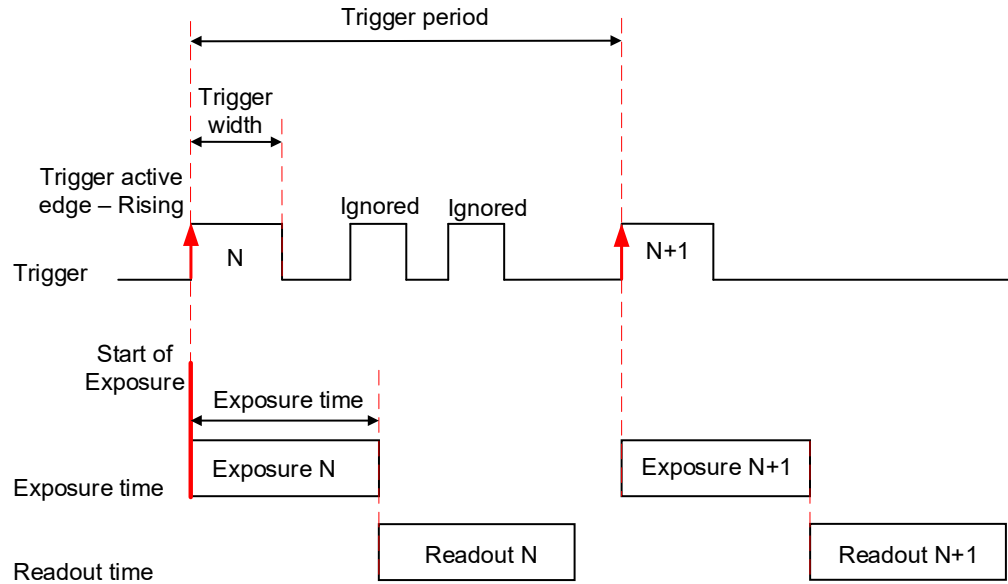

Setting exposure control mode to **Trigger Width** allows the external timing pulse to control the exposure duration.

Standard trigger mode, Exposure control is Trigger Width

GenICam controls

TriggerMode: **On**
 TriggerType: **Standard**
 TriggerSource: **Line 1** (or Line2, Pulse Generator)
 TriggerActivation: **Rising Edge** (or Falling Edge)
 TriggerDelay, TriggerDebounceTime: **set if applicable**
 ExposureMode: **Trigger Width**

Parameters of the external trigger pulse

Trigger width: $\geq 10 \mu\text{s}$
 Trigger period (min) = Exposure time (max) + Readout time

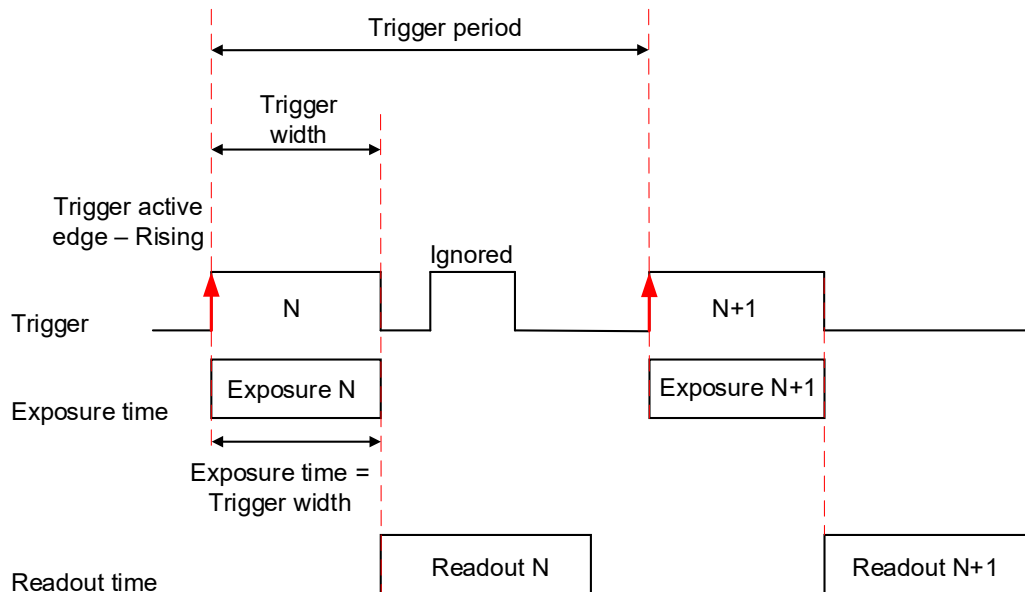

The minimum trigger period is equal to the maximum exposure time plus the camera readout time:

$$\text{Trigger Period (min)} = \text{Exposure Time (max)} + \text{Readout Time,}$$

where the Readout Time is equal to the *CurrentFrameTime* (in free-running mode, with *AcquisitionFrameRateEnable* disabled).

If the next trigger pulse appears during the previous trigger period, the camera ignores it.

Fast Trigger Mode

In **Fast trigger mode**, the exposure period and readout period are overlapped in a way that is similar to free-running (untriggered mode). Fast trigger mode depends upon a constant and stable trigger source so the camera can position the exposure period to conclude just as the previous frame readout ends. If the trigger period varies, the exposure will vary with the trigger period and uneven image illumination or wavering image brightness will result.

An external timing pulse controls the start of the exposure when Exposure Mode is Timed. The new exposure ends just as the trigger period ends. The readout of the next frame begins with the next trigger. If the next trigger pulse appears during the previous trigger period, the camera ignores it.

Fast trigger mode, Exposure control is Timed

GenICam controls

Trigger Mode: **On**

Trigger Type: **Fast**

Trigger Source: **Line 1** (or Line2, Pulse Generator)

Trigger Activation: **Falling Edge**

TriggerDelay, TriggerDebounceTime: – **set if applicable**

Exposure Mode: **Timed**

Exposure Time: **User-specified** (Min. = 1 line time, camera-dependent;
Max = 16 s)

Parameters of the external trigger pulse:

Trigger width: $\geq 10 \mu\text{s}$

Trigger period (min) = Readout time

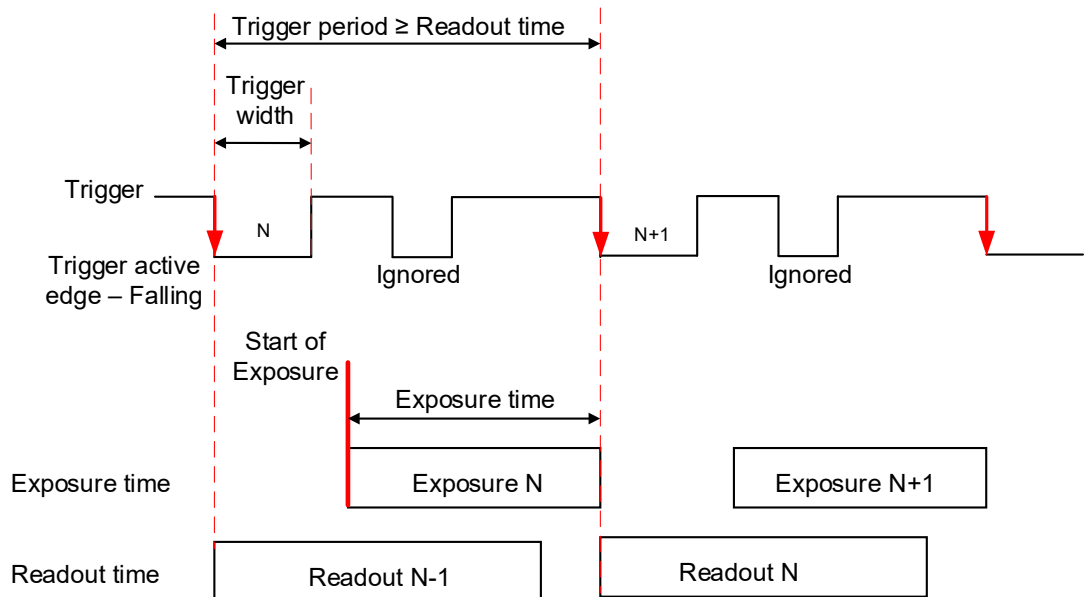

An external timing pulse controls the start and duration of exposure when *ExposureMode* is Trigger Width. The new exposure begins with the next trigger pulse during the readout of the current frame.

Fast trigger mode, Exposure control is Trigger Width

GenICam controls

TriggerMode: **On**

TriggerType: **Fast**

TriggerSource: **Line 1** (or Line2, Pulse Generator)

TriggerActivation: **Falling Edge**

TriggerDelay, TriggerDebounceTime: **set if applicable**

ExposureMode: **Trigger Width**

Parameters of the external trigger pulse

Trigger width: $\geq 10 \mu\text{s}$

Trigger period: \geq Readout time

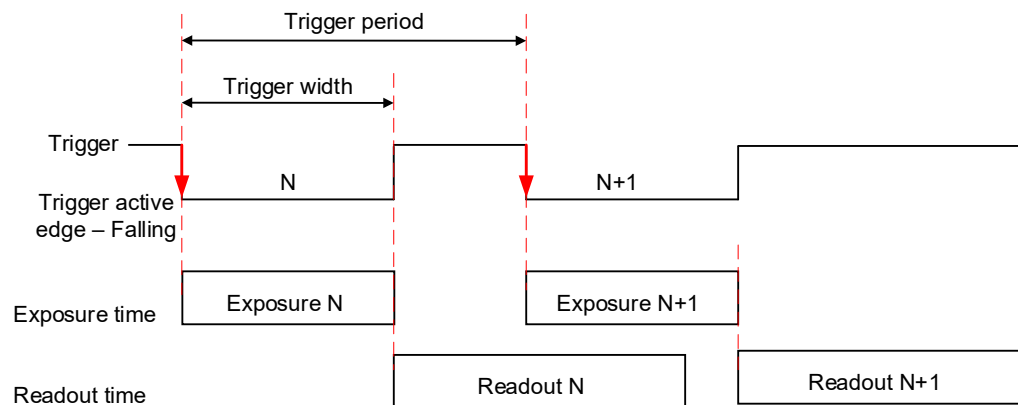

Trigger Sources

In the normal mode of operation, the camera is free running, which means the camera continually reads out the sensor. If using a trigger to initiate readout, trigger mode enables synchronizing the camera to a timing pulse.

The camera offers five sources for triggering: external Line1 or Line2, internal (pulse generator), software, and trigger over Ethernet. You can map the trigger signal to a corresponding camera input.

- **Line 1** – hardware Input Line GP Input1 (Trigger 1) is used as external source for the trigger signal.
- **Line 2** – hardware Input Line GP Input2 (Trigger 2) is used as external source for the trigger signal (Line 2 is not available in C2000, C2400, and P67 cameras as they have only one input).
- **Pulse Generator** – trigger source is generated by camera's internal Pulse Generator.
- **Software** – the camera expects a computer to send a command to the camera for generating one short trigger pulse. You can trigger the camera by clicking the GUI Software Trigger button or by sending the GenICam™ Trigger Software command.
- **Action0** – trigger source is generated by software using the Action command #0 (Trigger over Ethernet).

Configuring the Trigger

To configure the camera to work in **Trigger mode**, follow the steps below:

1. Turn off the camera image acquisition.
2. Make sure that *AcquisitionFrameRateEnable* is False.
3. In the Acquisition Control menu, set *TriggerMode* to **On**.
4. Set *TriggerType* to either Fast or Standard.
5. Select *TriggerSource*:
 - If *TriggerSource* is either Line1 (Input1) or Line2 (Input2), configure the external trigger signal source.
 - If *TriggerSource* is PulseGenerator, configure the camera's internal pulse generator (see [Pulse Generator](#) section) and make sure that the *PulseGenEnable* setting is checked.
 - If *TriggerSource* is Software, you do not need to configure a signal source. The camera generates one short trigger pulse when you click the GUI Software Trigger button or send the GenICam™ Trigger Software command.
6. In Fast Trigger mode, make sure that *Trigger Activation* is set to Falling Edge.
7. In Standard trigger mode, set *TriggerActivation* to either Rising or Falling Edge.

NOTE *

If the *TriggerActivation* is RisingEdge and *ExposureMode* is set to TriggerWidth, the exposure duration will be the time the trigger stays high.

If *TriggerActivation* is FallingEdge and the *ExposureMode* is set to TriggerWidth, the exposure time will last as long as the trigger stays low.

8. If applicable, set the number of frames to acquire for each trigger using set *TriggerNumFrames*.
9. If applicable, set *TriggerDebounceTime* and *TriggerDelay* to desired values. The *TriggerDebounce* feature is used to prevent false triggering when a trigger signal is being generated by an external source mapped to the camera's Input 1 or Input 2.

TriggerDebounceTime Defines the time period following a triggering event in which no additional triggers will be accepted by the camera. The camera ignores any pulses during the *TriggerDebounceTime* after receiving the trigger signal.

TriggerDelay Defines the time between the beginning of the trigger pulse and the beginning of the exposure. The camera captures an image with some delay after the trigger event.

Trigger pulse width: $\geq 10 \mu\text{s}$
 Max. *TriggerDebounceTime* = 65535 μs
TriggerDebounceTime \leq Trigger period
 Max. *TriggerDelay* = 1000000 μs

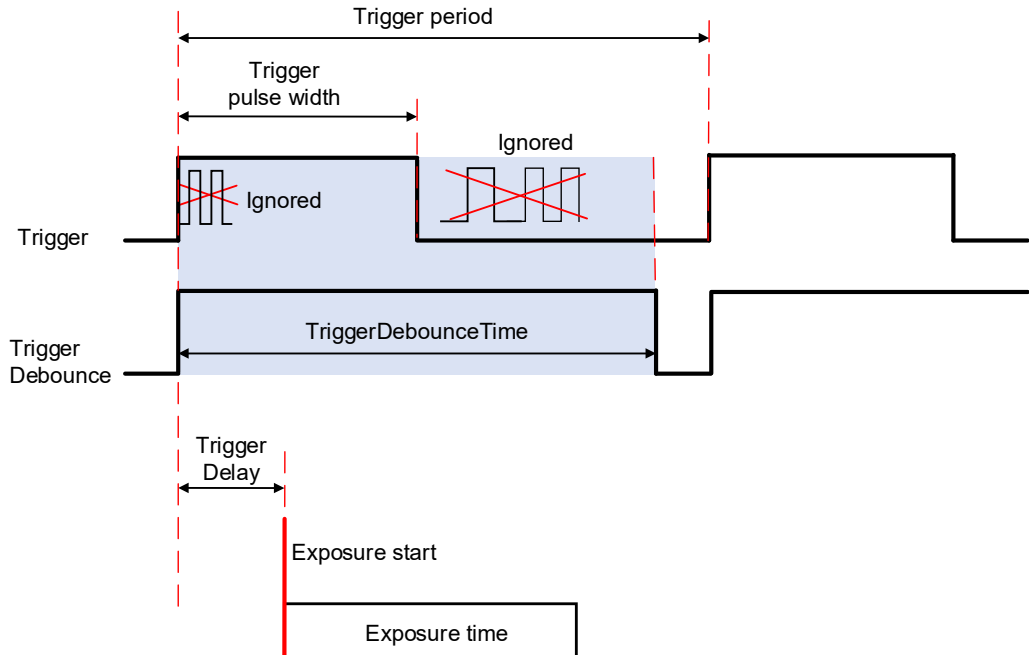

Strobe and Synchronization Controls

The camera allows you to synchronize your system from several references. You can synchronize with the trigger input, the start, middle or end of exposure, or the vertical/horizontal synchronization signals.

Output Signal	Description
None	No signal
ExposureStart	A short pulse indicating the beginning of the camera exposure
ExposureEnd	A short pulse indicating the end of the camera exposure.
MidExposure	A short pulse indicating the middle of the camera exposure.
ExposureActive	The output signal is active for the duration of exposure time
HSync	Maps horizontal sync signal
VSync	Maps vertical sync signal
OddEvenFrame	Maps odd or even frame
TriggerActual	Maps the input trigger pulse to the output with no delay
TriggerDelayed	Maps the input trigger pulse to the output with trigger delay
CameraReady	Short signal indicating that a camera is ready to receive the next trigger
PulseGenerator	Maps the internal pulse generator waveform to the output
Strobe1	Maps the Strobe 1 signal to the corresponding external output
Strobe2	Maps the Strobe 2 signal to the corresponding external output
ToggleOut	Used to check Out1 or Out 2. Sets Out in 1 or 0

The camera provides signals indicating the start of exposure, mid-exposure, and end of exposure. These signals have a fixed duration of 2 microseconds. These signals can be delayed using the *TriggerDelay* feature in the Acquisition Control menu to also synchronize multiple cameras or light sources. If a longer pulse period is required, the strobe feature can be used.

The camera also provides two strobes for synchronization with an external light source, other cameras, or peripheral devices. The strobes start just as the exposure begins and can be activated on all frames or just even or odd frames. You can position each strobe pulse within the entire frame-timing period with a precision of 1.0 microsecond.

Configuring the Strobe

You can set the strobe pulse duration (*StrobeWidth*) and the delay (*StrobeDelay*) with respect to the start of the exposure. The strobe period is equal to the frame time. You can map a strobe to either Output 1 or Output 2.

1. In the Strobe menu, set *OUT1Selector* to Strobe1.
The strobe is mapped to the Output1.
2. Select *OUT1Polarity* (ActiveHigh or ActiveLow)
3. Select *Strobe1Mode* (EachFrame, OddFrame, or EvenFrame)
4. Set *Strobe1Width* and, if applicable, *Strobe1Delay* to a desired value.
Without a delay, the strobe occurs simultaneously with the start of exposure.

Strobes Positioned with Respect to the Start of Exposure, Fast Trigger Mode

GenICam controls

TriggerMode: **On**
TriggerType: **Fast**
TriggerSource: **Line1** (or Line2, Pulse Generator)
Trigger Activation: **Falling Edge**
TriggerDelay, TriggerDebounceTime: **set if applicable**

Strobe Control

OUT1:
OUT1Polarity: **ActiveHigh** (or Active Low)
OUT1Selector: **Strobe1**
Strobe1Mode: **Each Frame** (or Odd Frame, or Even Frame)
Strobe1Width: **User-specified time** (Min. = 10 μ s)
Strobe1Delay: **User-specified time** (in μ s)

ExposureMode: **Timed**

ExposureTime: **User-specified** (Min.: camera-dependent, in μ s; Max = Readout time)
ExposureAuto: **Off**

Parameters of the strobe signal

Strobe period = frame time

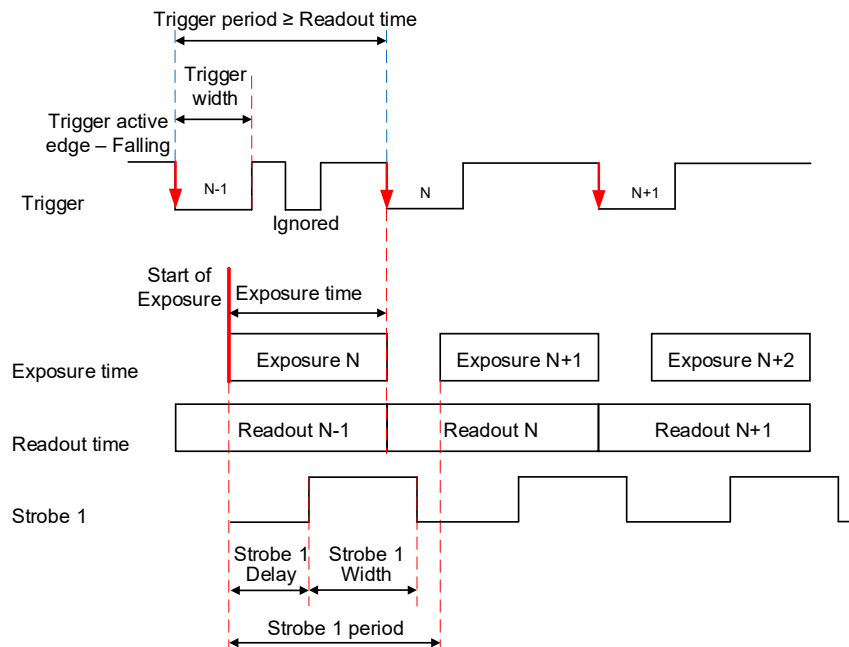

Area of Interest

For some applications, you might not need the entire image, but only a portion of it. To accommodate this requirement, the Cheetah camera allows you to create one Region of Interest (ROI), also known as an Area of Interest (AOI).

Horizontal and Vertical Window

Set the starting and ending point for each AOI independently in the horizontal direction (Horizontal Window) and the vertical direction (Vertical Window) by setting the window (H & V) offset and (H & V) size. The horizontal dimension is limited to multiples of 32 pixels, and the vertical dimension is limited to multiples of 8 pixels. In normal operation, the AOI defines the number of columns and rows output. The maximum horizontal window size (H) and the vertical window size (V) are determined by the camera’s image full resolution.

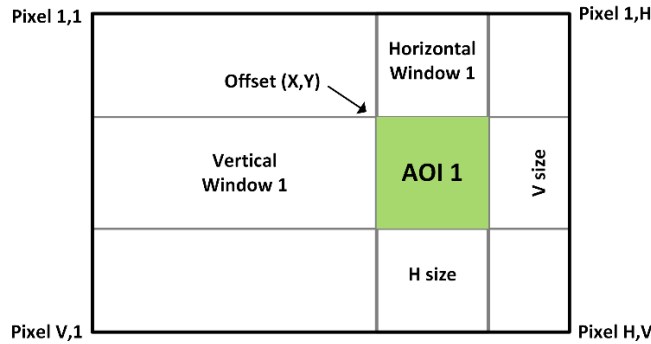

NOTE * For color version with AOI enabled, use an even number for Offset X and Offset Y to achieve proper color reconstruction and white balance.

Factors Impacting Frame Rate

The camera frame rate depends upon a number of variables including the exposure time, number of rows and columns in the AOI, and the bandwidth of the output interface.

AOI size: Camera frame rate increases by decreasing either the number of columns or number of rows read out. Changing the number of rows read out causes the largest change in frame rate.

Exposure Time: In free-running or Fast trigger mode, the camera overlaps the exposure time and image readout so frame rate has no dependence on exposure time. In Standard trigger mode, however, the exposure and readout time do not overlap, and long exposure times will decrease frame rate.

Decimation: The camera supports both binning and sub-sampling decimation to reduce the output resolution. Binning and sub-sampling increase the sensor frame rate. However, sub-sampling offers the largest frame rate improvement by reducing the number of rows and

columns read out from the image sensor. Binning and sub-sampling provide about a 2x to 3x increase in frame rate

Slave AOI

A Slave AOI (SAOI) used to apply a look-up table (LUT) to a selected region of the image or to calculate white balance coefficients from a selected region within the image. The selected region can be within the SAOI or outside the SAOI (Exclude option). Alternatively, the SAOI can be used to further refine the camera output so that only the pixels within the SAOI are output or only pixels within the ROI, but outside the SAOI (Exclude option) are displayed. When SAOI is enabled with AEC/AGC, the auto gain and auto exposure corrections will use luminance values calculated from inside or outside the selected AOI and then apply the determined exposure and gain settings to the full image.

Test pattern	Description
Disable	Slave AOI disabled.
Include	Only pixels within the Slave AOI are included to the image, all pixels outside Slave AOI are excluded.
Exclude	Slave AOI pixels are excluded from the image, all pixels outside the Slave AOI are included.
AEC_AGC_Include	Pixels within the Slave AOI are used by Auto Gain Control (AGC) and/or Auto Exposure Control (AEC) to calculate the Luminance statistics.
AEC_AGC_Exclude	All pixels outside the Slave AOI are used for Auto Gain Control (AGC) and/or Auto Exposure Control (AEC) features to calculate the Luminance statistics.
AWB_Include	Pixels within the Slave AOI are used by the Auto White Balance (AWB) feature to calculate WB coefficients.
AWB_Exclude	All pixels outside the Slave AOI are used by the Auto White Balance (AWB) feature to calculate WB coefficients.
LUT_Include	The LUT is applied to pixels within the Slave AOI only.
LUT_Exclude	The LUT is applied only to pixels outside the Slave AOI.

NOTE (*) The POE-C2000 and POE-C2400 cameras do not support Slave AOI.

Binning and Sub-Sampling Decimation

Binning

The principal objective of the binning function is to reduce the image resolution with better final image quality than a sub-sampling function. Binning reduces the output resolution by summing several pixels together and has the advantage of reducing aliasing, increasing signal-to-noise ratio (SNR). Sub-sampling — as opposed to binning — has the advantage of increasing the output frame rate by reducing the number of rows read out, but also can introduce aliasing in the final image. Sub-sampling, however, increases the output frame rate more than binning.

The following graphic illustrates the concept of 4:1 binning for a monochrome image sensor. The values of pixels P1, P2, P3 and P4 are summed together resulting in a single larger pixel output value.

The binning feature can be used on the full resolution image or within any area of interest.

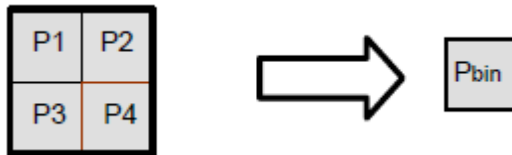

NOTE ⚠ You cannot apply both binning and sub-sampling decimation simultaneously.

The following cameras support binning:

Camera Model	Sensor Type
POE-C1911, POE-C3210, P67-C1911, P67-C3210, POE-C4410, POE-C5410, POE-C6410, POE-C4410-T, POE-C5410-T, POE-C6410-T	Monochrome only

Sub-Sampling Decimation

Sub-sampling reduces the number of pixels output by reducing the output frame size but maintains the full field of view. If an area of interest (AOI) is selected, then the field of view of the AOI is maintained.

The cameras employ a “keep one pixel, skip one pixel” sequence. When enabled in both x and y, every other pixel within a line is retained, and every other line within the image is retained.

Monochrome subsampling:

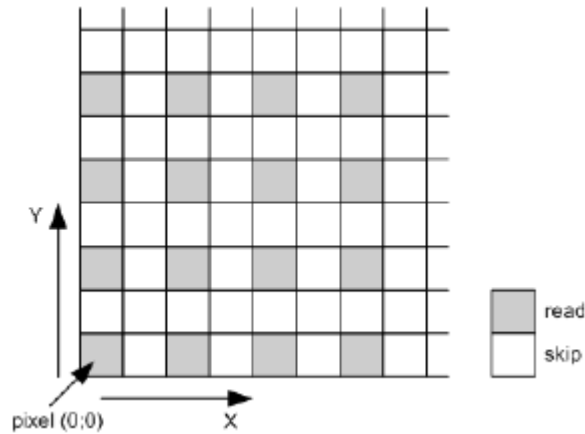

Color subsampling:

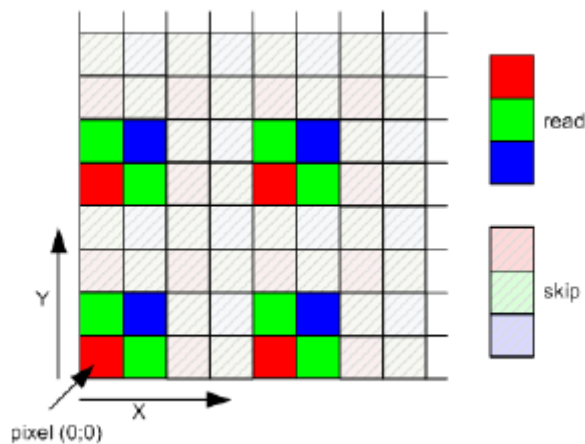

NOTE (*) The POE-C2000 and POE-C2400 cameras do not support decimation.

Transfer Function Correction

The user-defined LUT (Lookup Table) feature transforms any 12-bit video data into any other 12-bit value. The camera supports four separate LUTs. All LUTs are available for modifications. You can generate a custom LUT and upload it using the Imperx Upload Utility (see [Uploading the LUT File](#)).

Factory LUTs

Each LUT consists of 4096 entries, with each entry being 12 bits wide. LUT1 and LUT3 are factory programmed with a standard Gamma 0.45, LUT2 and LUT4 are pre-programmed with negative LUT ($LUT_{OUTPUT} = 4095 - LUT_{INPUT}$).

The Gamma 0.45 LUT uses the following formula:

$$LUT_{OUTPUT} \text{ (ADU with 12 bpp)} = 4095 * [(LUT_{INPUT}/4095)^{0.45}]$$

For example, if the LUT_{INPUT} is 1024 ADU (12 bpp), then LUT_{OUTPUT} is $4095 * (1024/4095)^{0.45} = 2195$.

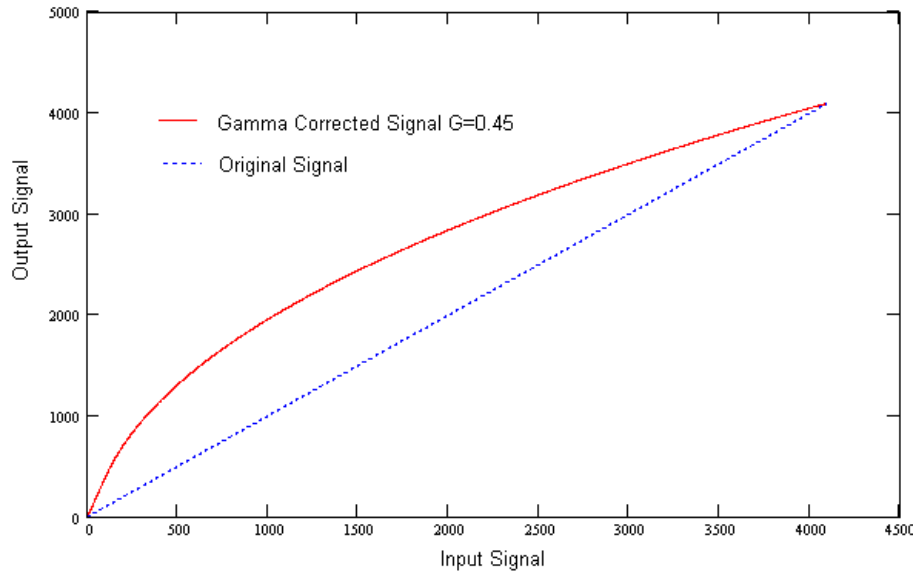

User-Defined LUTs

You can define any 12-bit to 12-bit transformation as a user LUT and upload it to the camera using Imperx Upload Utility (see [Uploading the LUT File](#)). You can specify a transfer function to match the camera's dynamic range to the scene's dynamic range. There are no limitations to the profile of the function. The LUT must include all possible input values (0 to 4095) (refer to the [Appendix C: Look Up Tables](#)).

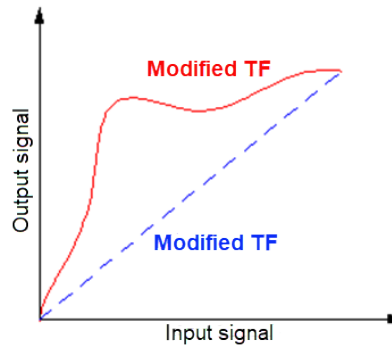

Bad Pixel Correction

A CMOS imager is composed of a two-dimensional array of light sensitive pixels. In general, the majority of the pixels have similar sensitivity. However, some pixels deviate from the average pixel sensitivity and are called *defective pixels* or *bad pixels*.

In most cases, bad pixels are responsive to light, and rarely is a pixel totally dark or totally bright. At the factory, final testing identifies and corrects bad pixels using bad pixel correction.

The Cheetah GigE Vision cameras employ static bad pixel correction. During factory testing, engineers identify the coordinates of bad pixels. They create a map file listing the pixel coordinates of these pixels by row and column, and the camera corrects the bad pixels found at these coordinates. The map file downloads into the camera's non-volatile memory.

When Factory or User correction is enabled, the camera compares each pixel's coordinates with entries in the pixel map. If a match is found, the camera corrects the defective pixel.





You can create your own Bad Pixel Map (BPM) file and upload it using the Imperx Upload Utility application.

Flat Field Correction

The camera uses a factory installed flat field correction (located in FFC1) algorithm to correct some of the image sensor's non-uniformity. You can upload your own FFC table to FFC2. While not recommended, you can disable the FFC. If two FFC correction tables are needed, you can also overwrite the factory installed FFC located in FFC1.

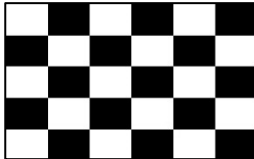
Test Image Pattern

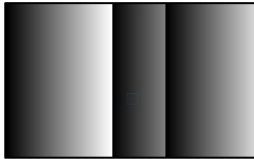
The camera can output several test images to verify the camera's general performance and connectivity to the computer. This ensures that all the major modules in the hardware are working properly and the connection between your computer and camera is synchronized, that is, the image framing, output mode, communication rate, and so on are properly configured. Note that test image patterns do not exercise and verify the image sensor functionality. The following table show a list of test images available.

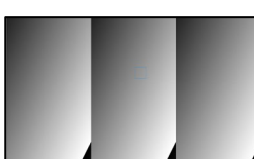
Test pattern	Description	Pattern
Off	Image is coming from the sensor	
BwCheckerBoard	A black and white checkerboard pattern	
Grey	A uniformly dark grey image. You can set the value	
TapSegmented	Image segmented by each tap output	
GreyHorizontalRamp	Image is filled horizontally with an image that goes from the darkest possible value to the brightest	
GreyVerticalRamp	Image is filled vertically with an image that goes from the darkest possible value to the brightest	
HorizontalAndVerticalRamp	A pair of horizontal and/or vertical lines positioned in the image at any pixel/line in the image	

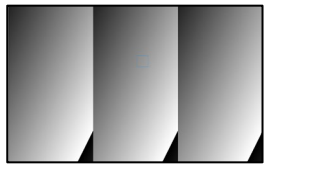
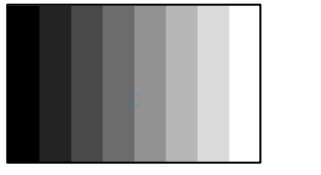
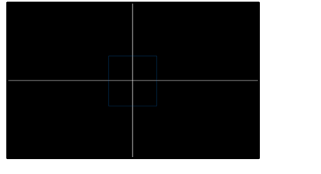
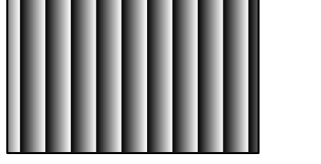
Test pattern	Description	Pattern
HorizontalAndVerticalRamp Moving	A moving horizontal and vertical ramp image	
VerticalBars	A set of 8 vertical gray bars with different gray levels	
Crosshair	Displays a cross-hair in the absolute center of the image. A live image is superimposed under the cross-hair pattern. Cross-hair has a thickness of two pixels	
IpxGevPattern	Image is being generated by GEV engine Firmware	

Color Control

The camera provides white balance options for controlling image color under different lighting conditions. White balance control options are Off, Once, Continuous, and Manual. You can load the camera with your preferred white balance coefficients or let the camera determine the color coefficients one time or continuously (auto).

AWB Mode	Description
Off	No white balance correction performed.
Once	The camera analyzes one image frame, calculates only one set of coefficients, and corrects all subsequent frames with this set of coefficients.
Continuous	The camera analyzes every frame, derives a set of correction coefficients for each frame, and applies them to the next frame. You can select five tracking speeds.
Manual	The camera uses the correction coefficients you enter (0 is equal to 0.0x, 4095 is equal 4x gain). Also, see TIP below.

For best color reproduction when the source has a stable spectral output, Imperx suggests illuminating a uniformly grey card with the intended source then using the Once option to determine the coefficients and then saving these coefficients into the camera and saving this configuration to one of the User Spaces (see section [Configuration Memory](#)).

TIP

To get the best white balance for the R, G, and B coefficients when the spectral source is constant:

1. Image a grey or white target over the camera's entire field of view using the intended lighting source.
2. Select **Once** mode for the **White Balance**. The R, G, and B coefficients appear in the RedCoefficient, GreenCoefficient, and BlueCoefficient areas respectively.

Canon Lens Control

Make sure that a switch on your Canon EOS EF lens is set to Auto (AF), and Visibility is set to Guru on the IpxPlayer GUI screen:

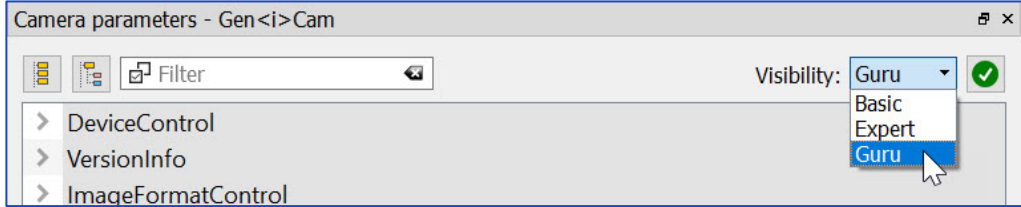

The camera initializes the lens upon power cycling. Check **Lens Controller Status** parameter. If the status is `InitLens_Done`, the initialization was successfully completed, and you can start adjusting the lens. If the initialization failed, issue **InitLens** command on Controller Setting screen.

Focus Control

1. For the camera to learn a range of the Canon lens’s Focus Encoder, issue the following sequence of commands:
 - a. Issue the *Canon Focus Near-Full* command.
 - b. Issue the *Reset Focus Encoder* command.
 - c. Issue the *Canon Focus Far-Full* command.
 - d. Issue the *Get Focus Encoder Status* command.
 - e. Issue the *Focus Set Max* command. The *Focus Max* parameter will be automatically set to the maximum value.

<ul style="list-style-type: none"> ▼ CanonLensControl <ul style="list-style-type: none"> > ControllerSettings ▼ Focus 		
NearFull	Execute	a.
FarFull	Execute	c.
FocusStepValue	1	
NearStep	Execute	
FarStep	Execute	
FocusReqPosition	0	
SetFocusPosition	Execute	
FocusMax	0	
FocusSetMax	Execute	e.
FocusEncoderStatus	0	
GetFocusEncoderStatus	Execute	d.
ResetFocusEncoder	Execute	b.

2. Set *FocusReqPosition* to a desired value.
3. Issue the *SetFocusPosition* command.
FocusEncoderStatus will change.

Focus Encoder is a Hall effect sensor and is not perfectly precise, so *FocusEncoderStatus* values can vary. It does not provide sufficiently accurate location information to set lens focus after power cycling. Error tends to increase with a number of focus movements. Once the lens is focused, it will retain focus after repeated power cycling.

Canon *FocusEncoderStatus* is a signed value (2's complement). Negative values can result if the Focus Encoder position is close to the Near Full position. For example, a value of 65352 means negative 184 or 184 steps past the Near Full Position.

Iris Control

A Canon EF EOS lens provides an iris range in raw units. A camera reads out an iris range from a Canon lens in raw units upon issuing the *GetIrisRange* command. Each time the iris is changed, the camera calculates and returns the *CurrentFNumber* using the following formula:

$$\text{CurrentFNumber} = \text{Sqrt}(2)^{[(\text{Raw unit}/8) - 1]}$$

For example, if Raw unit = 32, then CurrentFNumber = 2.83.

Using XML features *IrisRequestedPositionRaw* and *SetIrisPosition* you can set an aperture to a required value. The aperture will be changed with *IrisStepValue* until it is greater than or equal to the target position in raw units.

▼ CanonLensControl	
> ControllerSettings	
> Focus	
▼ Iris	
IrisRequestedPositionRaw	0
SetIrisPosition	Execute
CurrentFNumber	4.55515
OpenIrisFull	Execute
CloseIrisStep	Execute
OpenIrisStep	Execute
IrisStepValue	1
GetIrisRange	Execute
IrisMin	43
IrisMax	80
IrisRange	502B2B2B

NOTE (★) Only the POE-C4410, POE-C5410, POE-C6410, POE-C4410-T, POE-C5410-T, POE-C6410-T cameras support Canon EOS EF lens control.

Configuration Memory

The camera has built-in configuration memory divided into four segments: Work Space, Factory Space (Default), User Space #1, #2, #3 or #4. The Work Space segment contains the current camera settings while the camera is powered up and operational. All camera registers are located in this space. You can program these registers and change the camera configuration through these registers.

The Work Space is RAM based. All camera registers clear upon camera power-down. The Factory Space (Default) segment is ROM based, write protected, and contains the default camera settings. This space is available for read operations only. User Space #1, #2, #3 and #4 are non-volatile, flash-based, and used to store up to four user defined configurations or User Sets. Upon power up or software reset, the camera firmware loads the Work Space registers from the Factory Space (Default), User Space #1, #2, #3 or #4 as determined by a User Set Default Selector setting. At any time, a user can instruct the camera to load its Work Space with the contents of the Factory Space, User Space #1, #2, #3 or #4 using the User Set Load command. Similarly, the user can instruct the camera to save the current Work Space settings into either User Space #1, #2, #3 or #4 using the User Set Save command.

The non-volatile parameter Flash memory also contains the Bad Pixel Map (BPM), Flat Field Correction (FFC) tables and LUT #1, #2, #3 and #4 which you can load to the camera's internal memory upon enabling the corresponding camera feature. You can create custom LUT tables using the Imperx IPX Toolkit utility and upload these tables to the parameter Flash using the Imperx Upload Utility. Both the IPX Toolkit and IPX Upload Utility are available from the Imperx website <https://www.imperx.com/>. Imperx also has an application note describing how to update or create custom Bad Pixel Maps (BPM) which can then be uploaded to the camera using the Imperx Upload Utility.

Image Sensor Technology

General Information

A CMOS camera is an electronic device for converting light into an electrical signal. The C2010, C2410, C4010, C4110, C4410, C5410, and C6410 cameras contain the 2nd Generation Sony Pregius CMOS (Complementary Metal-Oxide Semiconductor) image sensors with 3.45-micron square pixels while the C1911 and C3210 cameras contain 3rd Generation Sony Pregius CMOS image sensors with 4.5-micron square pixels. The Pregius sensors have groundbreaking performance with sensitivity better than many traditional Charge Coupled Device (CCD) image sensors. The sensors have extremely low dark current and no visible fixed pattern noise, which has been the bane of traditional CMOS image sensors.

The Sony CMOS sensor consists of a two-dimensional array of sensitive elements called silicon photodiodes, also known as pixels. The photons falling on the CMOS surface create photoelectrons within the pixels. The number of photoelectrons is linearly proportional to the light level. Although the number of electrons collected in each pixel is linearly proportional to the light level and exposure time, the number of electrons created in the pixel during any fixed time period varies with the wavelength of the incident light.

When the camera reaches the desired exposure time, it shifts the charges from each pixel photodiode onto a storage register within the pixel, reads out one row at a time digitizing each pixel at 12 bits. The user can also selectively output the most-significant 8, 10 or 12 bits from each pixel with an impact to camera's frame rate. Frame time, or read-out time, is the time interval required for all the pixels to be read out of the image sensor. In non-triggered or fast trigger mode, while reading out the image from the storage registers within each pixel, the camera captures the next image. The exposure ends just as the readout of the previous frame ends and the next frame begins.

Unlike traditional CCD image sensors, the Sony CMOS image sensor digitizes each pixel within a row simultaneously. This allows for more settling time, which lowers the overall noise floor and provides improved sensitivity. The low noise floor, combined with a reasonably large pixel charge capacity and extremely low dark current, translates into a large dynamic range of 71 dB (12-bits) or 12 F-stops for 3.45-micron pixels and 77 dB (13-bits) or 13 F-stops for 4.5-micron pixels.

The sensor allows you to apply up to 48 dB of gain to the image. The first 24 dB of gain is analog gain and some improvement in noise performance may result. The camera applies the last 24 dB of gain digitally, which affects both signal and noise equally. Additional digital gain (up to 12 dB) can also be applied using the Digital Gain control.

Spectral Sensitivity

A set of color filters (red, green, and blue) arranged in a Bayer pattern over the pixels generates color images. The starting color is Red for SONY Pregius image sensors and follows the pattern: red, green, red, green, red, ... on row 1 and green, blue, green, blue, green, ... on row 2 and so on. The color and monochrome spectral responses of the sensors used in Cheetah cameras can be found in [Appendix A](#).

Micro-polarized Cameras

Light travels in electromagnetic waves that vibrate in multiple, random directions. When these unpolarized light waves strike certain surfaces, they tend to reflect or refract light and obscure the imaging target. A polarizer filter integrated into the camera can block certain light waves from reaching the image sensor and thereby improve image quality.

The Sony IMX250MY/ZR image sensor in the Cheetah POE-C2410Y/Z camera includes a micro-polarizer filter that blocks light waves based on a polarization angle. The filter consists of an array of four polarizers grouped in a 2x2 sub-array. As shown in the following illustration, each array covers a block of four pixels in the sensor with each polarizer absorbing light at one of four angles: 90 degrees, 45 degrees, 135 degrees, or 0 degrees.

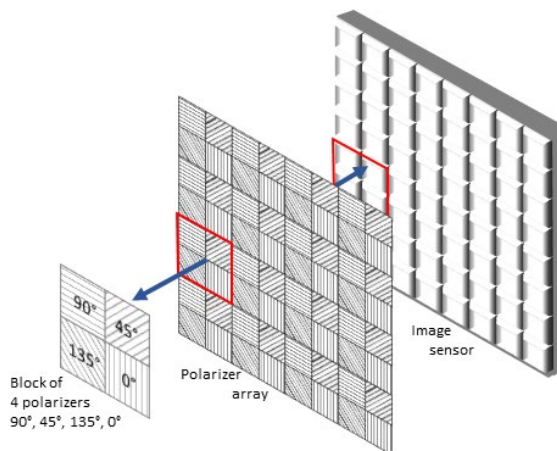

Appendix A: Spectral Response

Cheetah C1911 Spectral Response

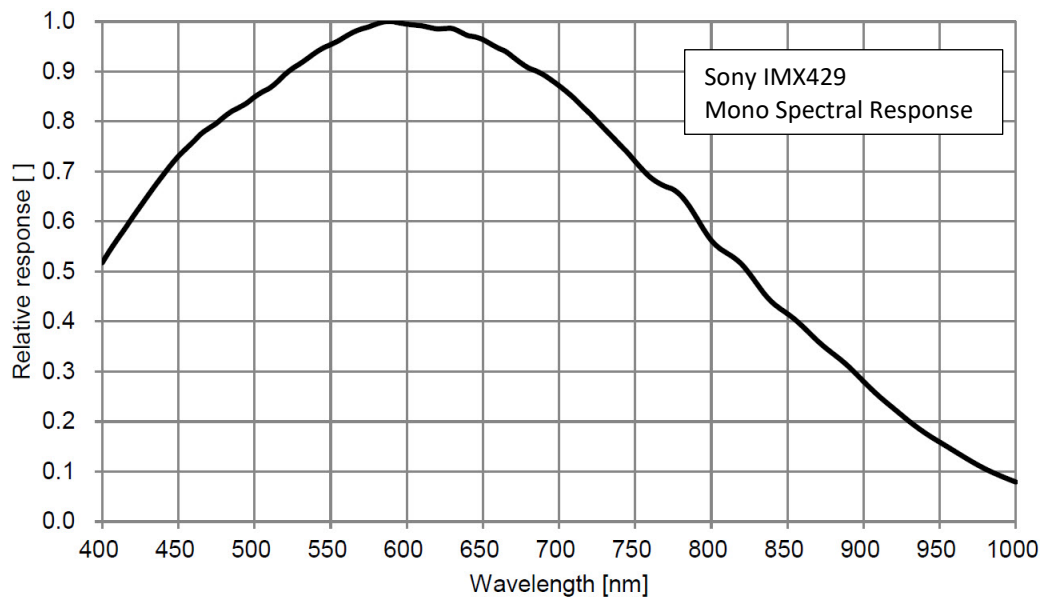
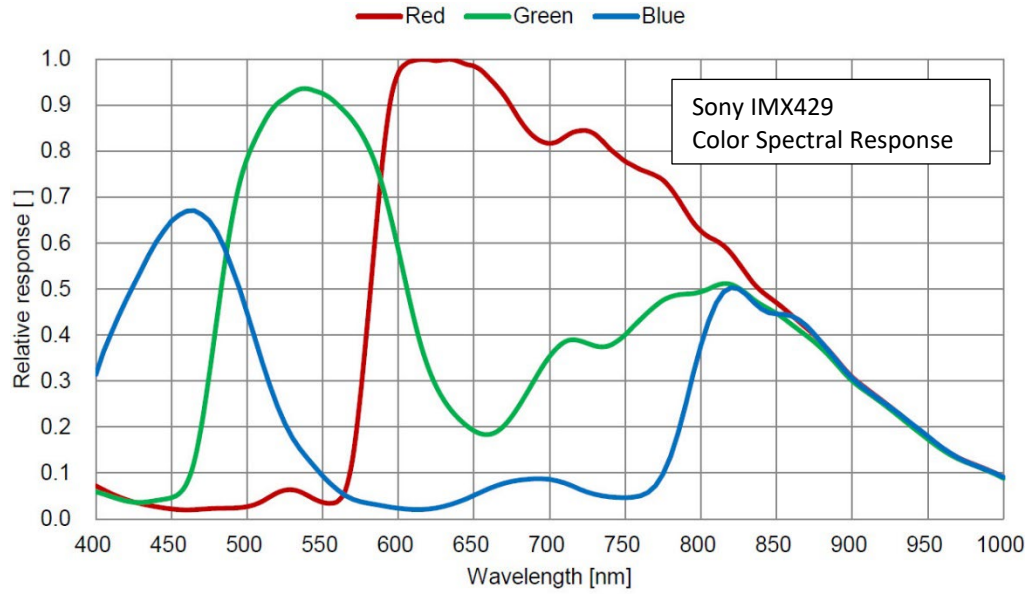

Cheetah C2000 and C210 Spectral Response

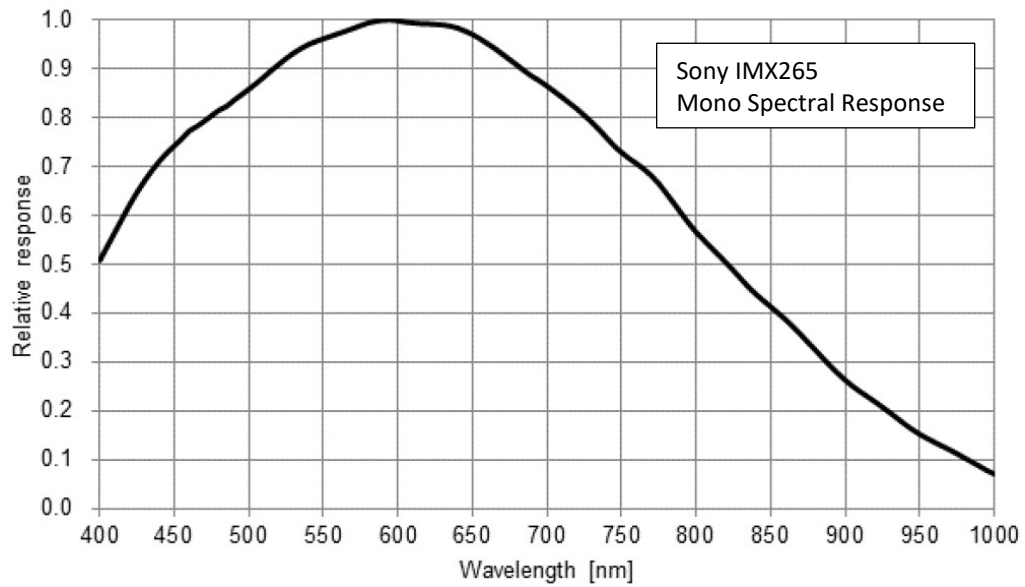
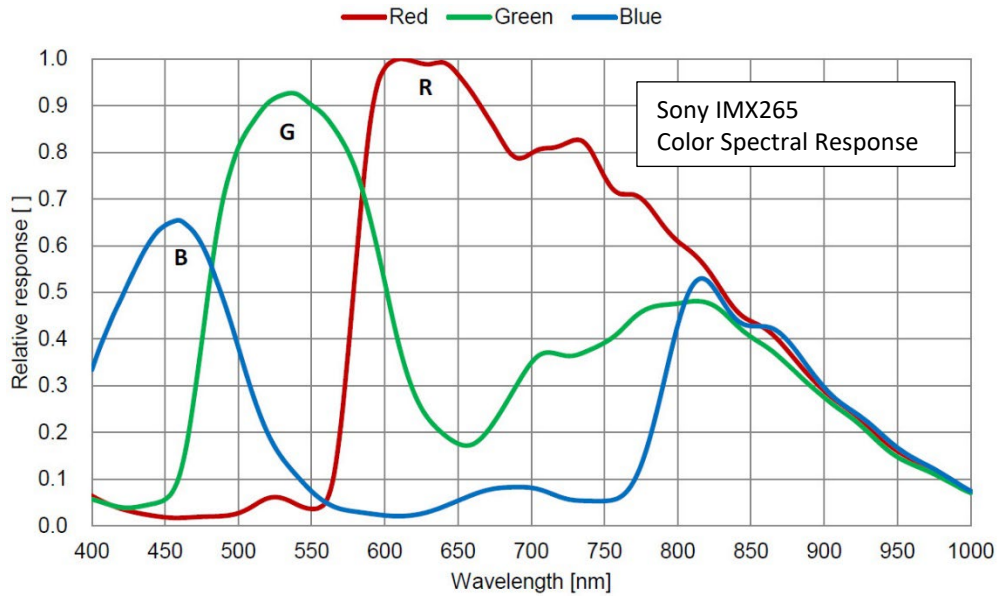

Cheetah C2400 and C2410 Spectral Response

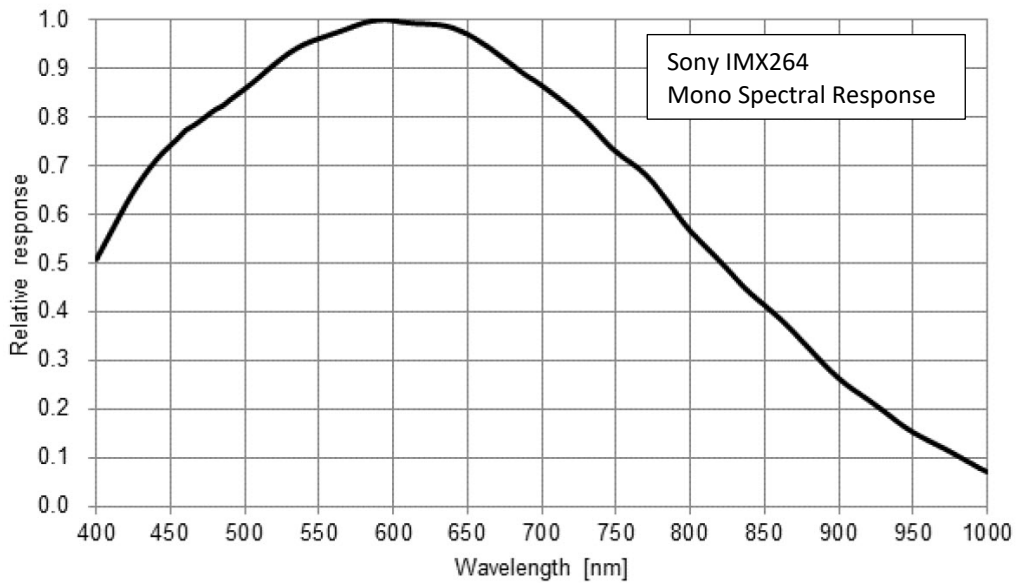
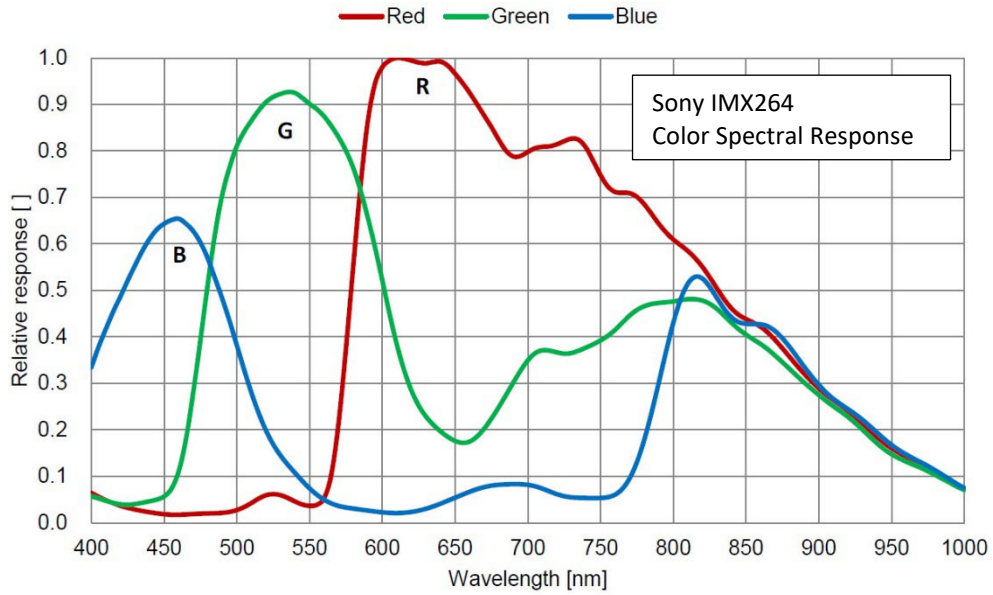

Cheetah C2410Y/Z Spectral Response

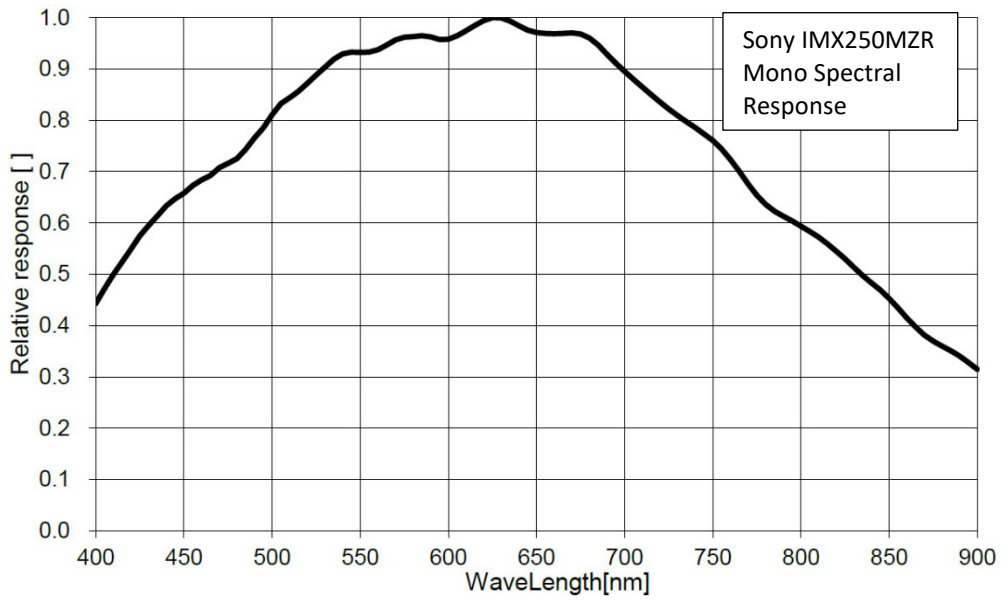
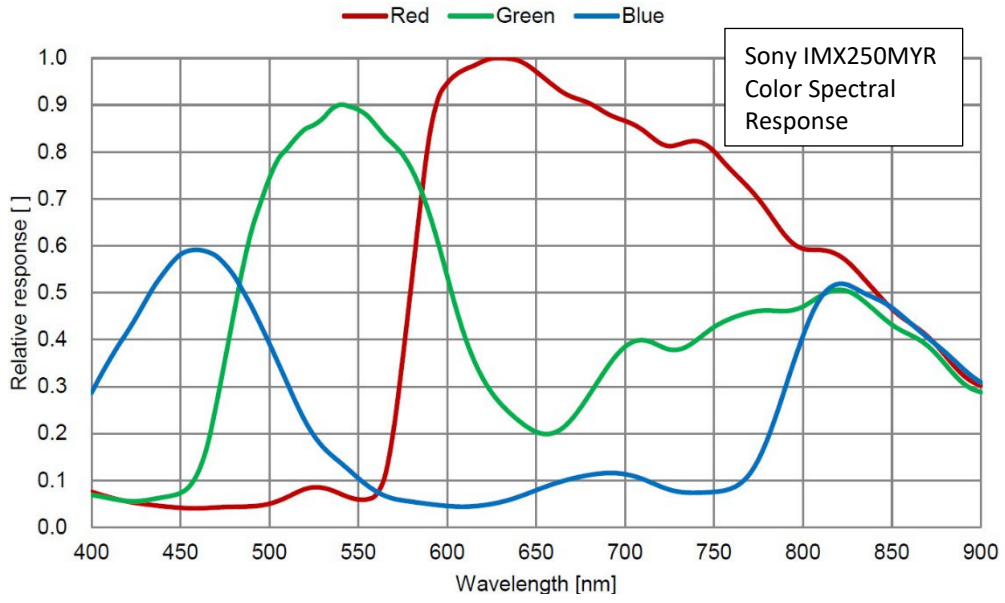

Cheetah C3210 Spectral Response

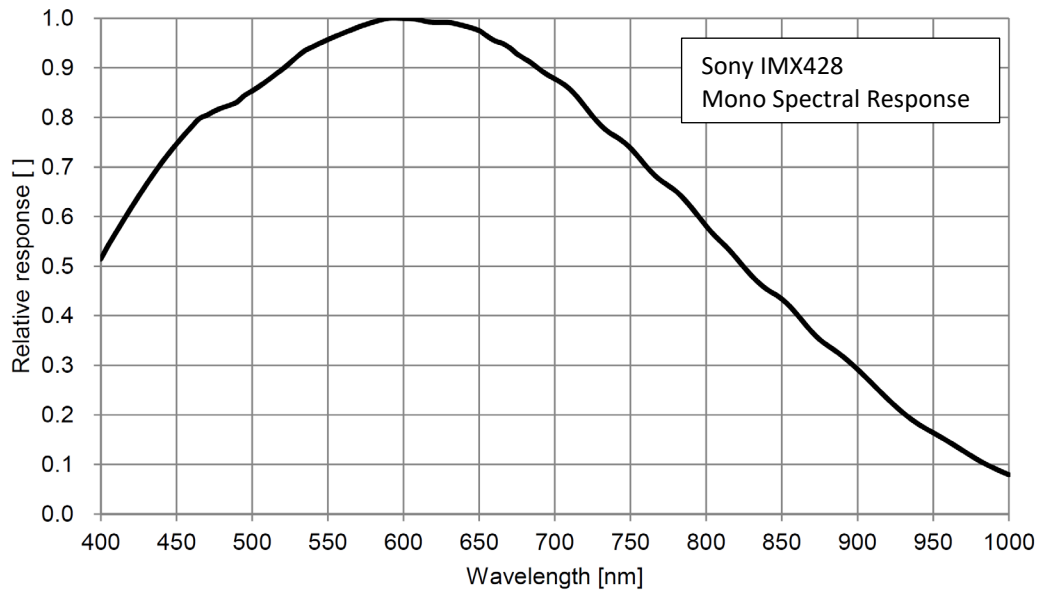
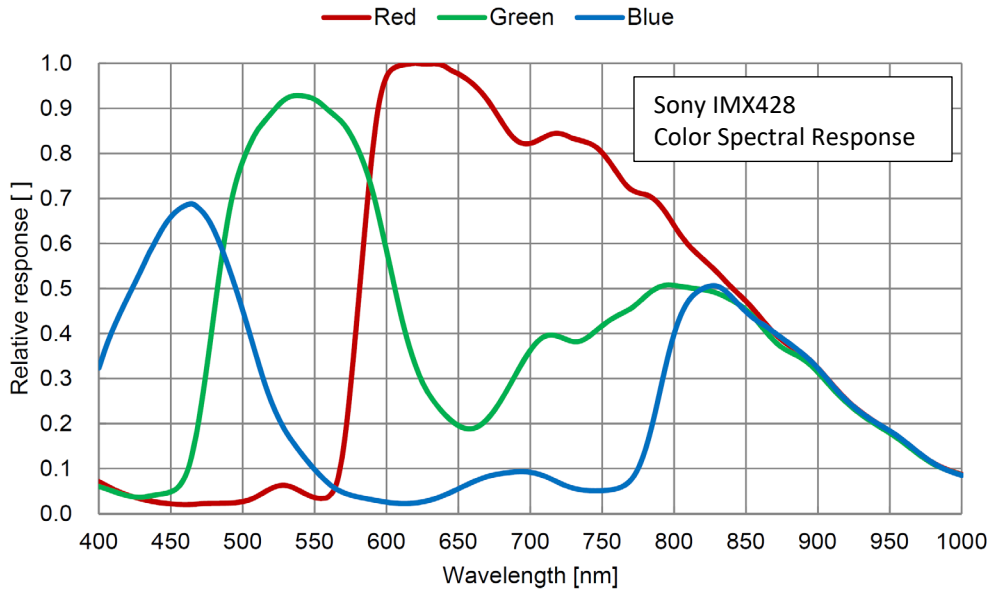

Cheetah C4010 Spectral Response

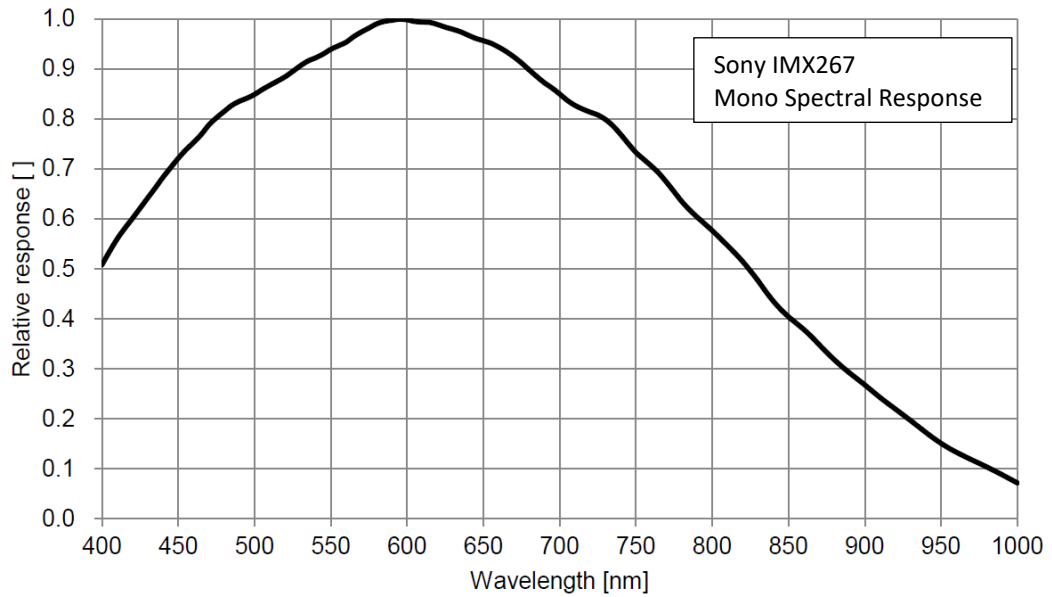
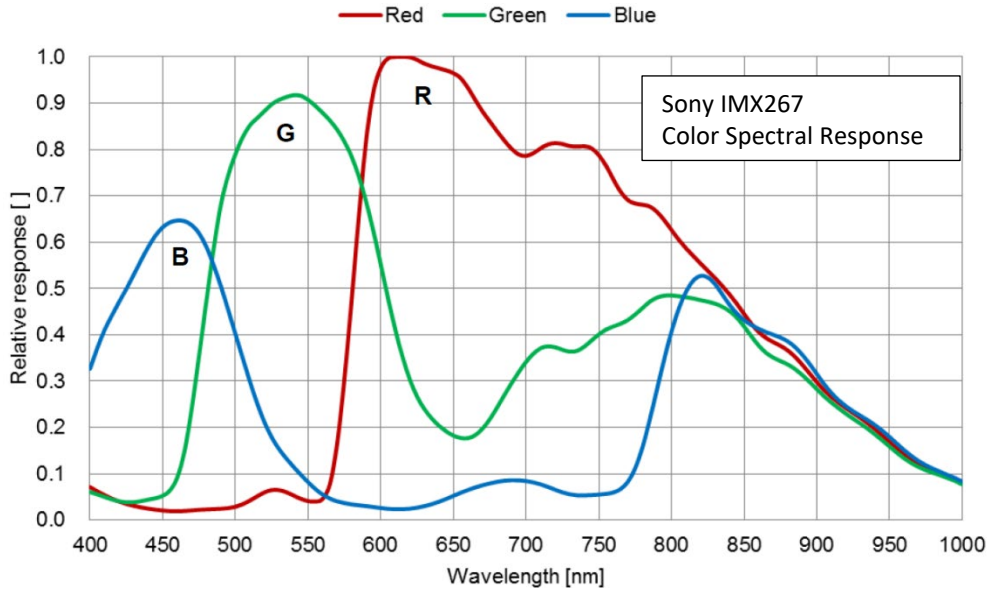

Cheetah C4110 Spectral Response

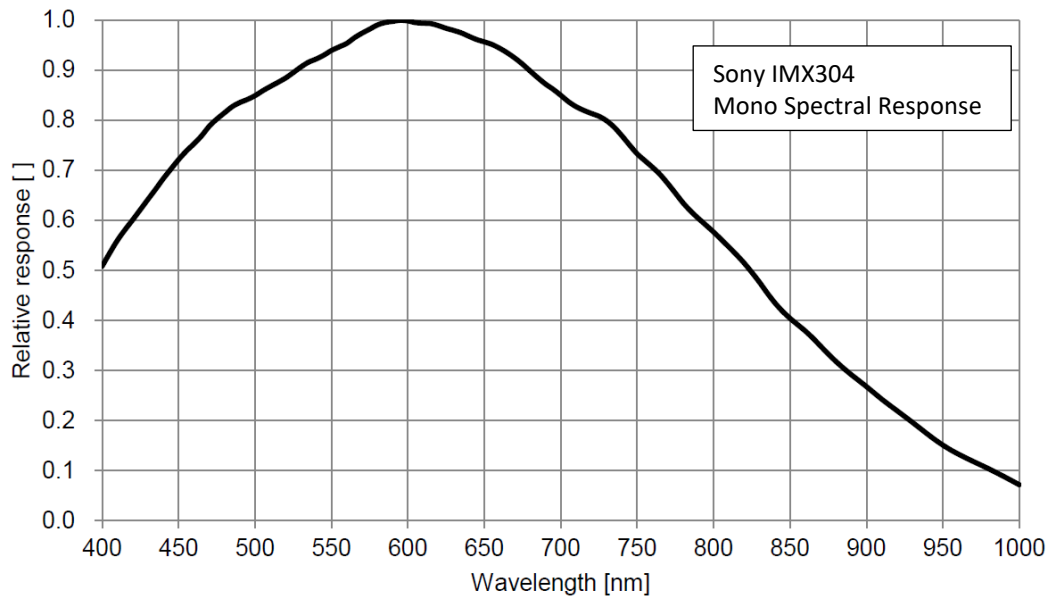
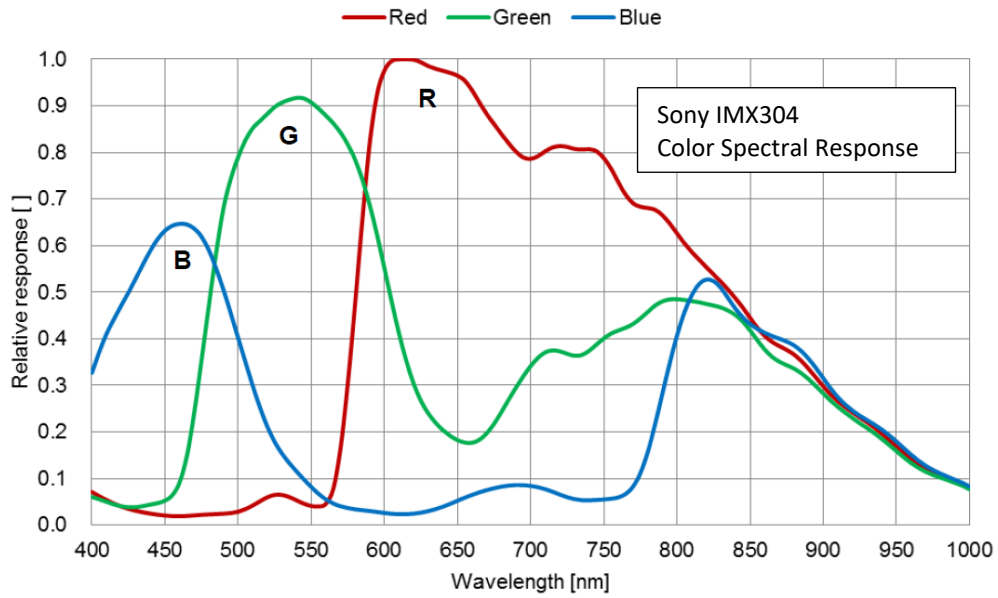

Cheetah C4410 Spectral Response

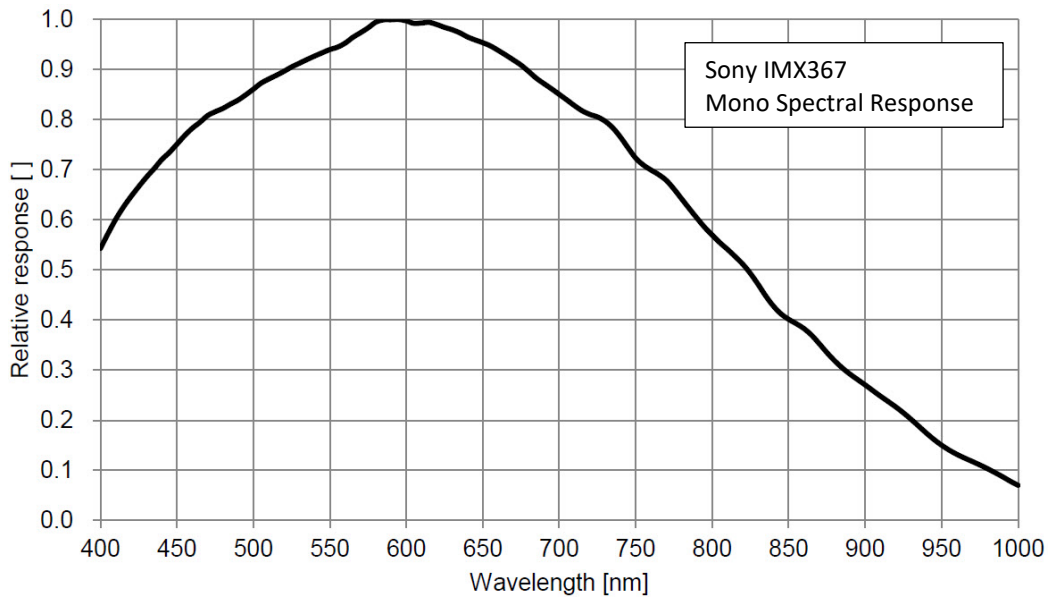
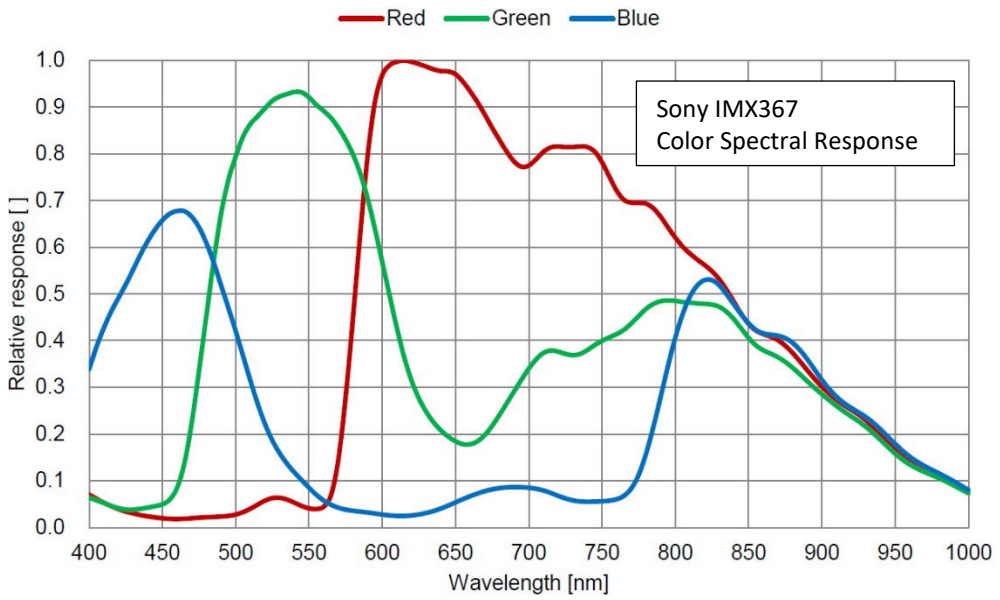

Cheetah C5410 Spectral Response

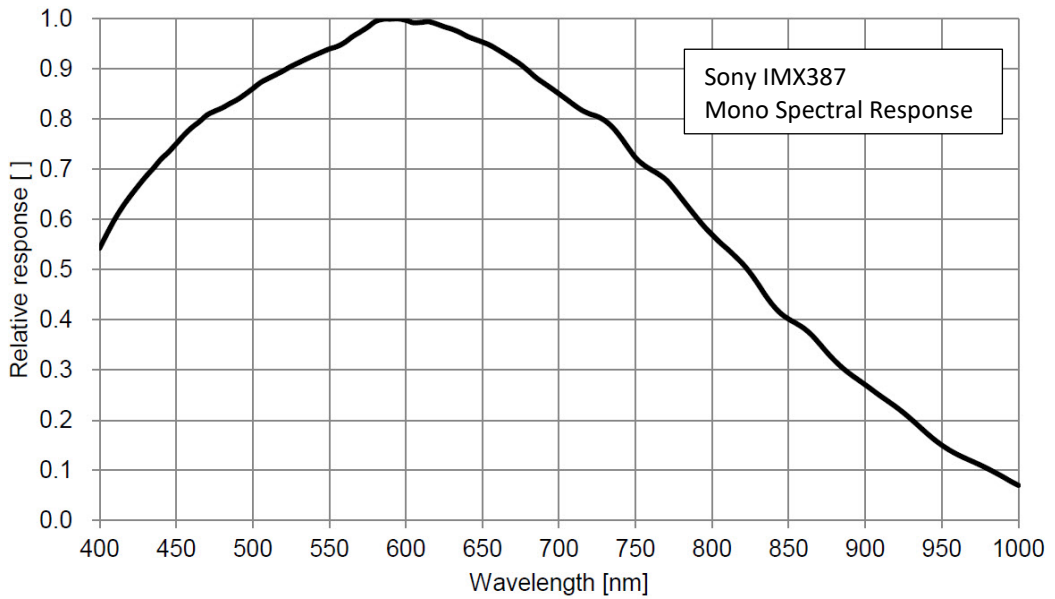
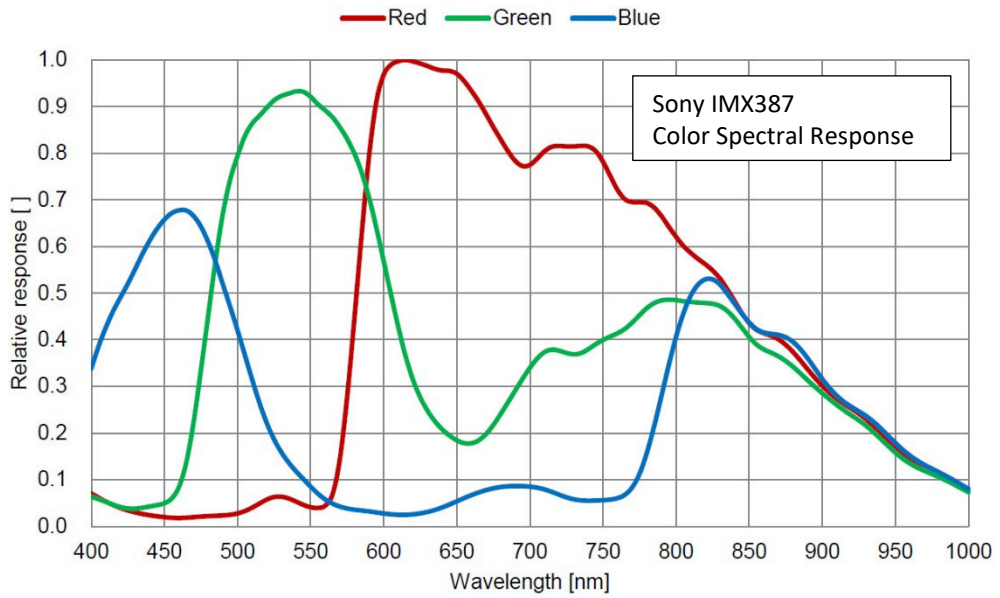

Cheetah C6410 Spectral Response

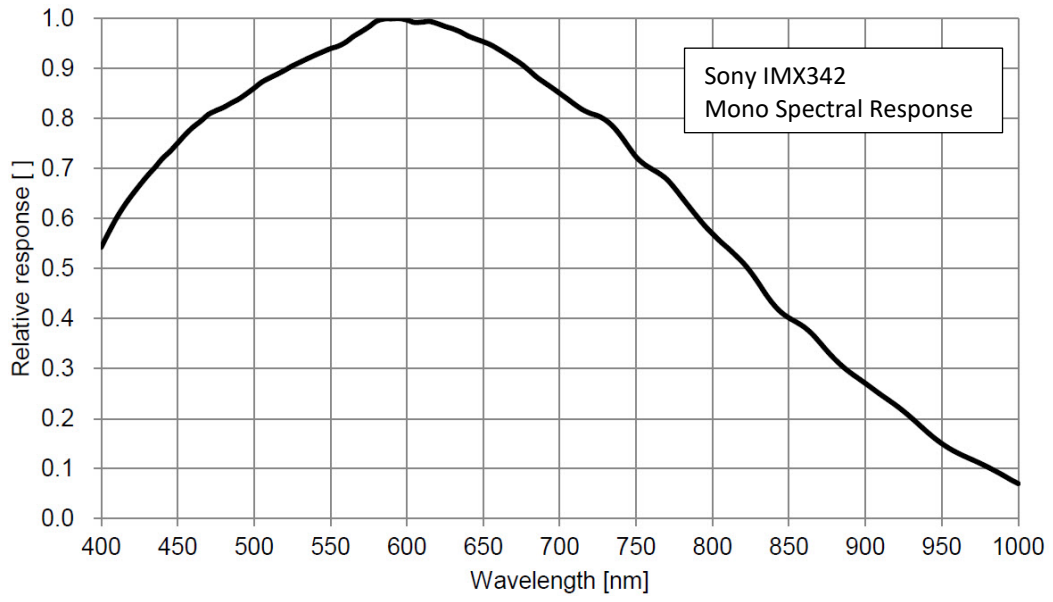
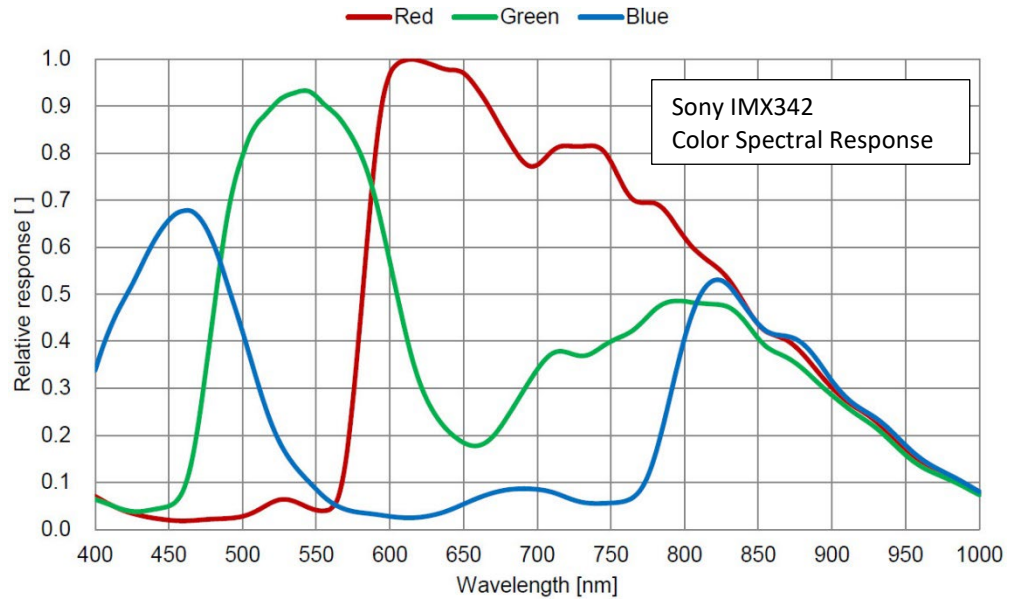

Appendix B: Creating Bad Pixel Correction Maps

Overview

Bad Pixel Correction (also known as Hot Pixel Correction) and Dead Pixel Correction work with predetermined and preloaded Bad and Defective pixel maps. Bad Pixel Map (BPM) and Defective Pixel Map (DPM) are uploaded into the camera's non-volatile memory.

You can edit the original (factory installed) BPM file and upload it into the camera to fit the unique requirements of your operating environment or camera use.

The original DPM file cannot be changed.

Editing BPM Files

TIP ⓘ

To obtain the factory BPM file, contact Imperx technical support at:

Email: support@imperx.com

Toll Free: 1 (866) 849-1662 or (+1) 561-989-0006

Visit our website: www.imperx.com.

To create an BPM that contains all the bad pixels, including those on the factory BPM, see [Creating a BPM Using Imperx Toolkit](#).

To upload a new BPM to the camera, see [Uploading a BPM File](#).

You can edit BPM file in Microsoft Notepad or any other editing software. The file is a simple text file that looks like this:

```
-- Defective Pixel Map,  
-- Date: 05.18.2020,  
-- Model#: SFP-C6440M,  
-- Serial#: LAC001,  
:Table,  
-- Column (X) , Row (Y)  
    5683,155  
    3091,332  
    3532,893  
    650,1017  
    701,1017  
    1712,1053  
    914,1067
```

Pixel maps have two main sections: a header and a table. The header section is a free text area of up to 256 ASCII characters. Each line of the header section must be terminated with a comma. The table section of the file contains an array of lines with each line containing an X (column number) value followed by a comma and a Y (row number) value.

All pixels are listed in the BPM in order of increasing Y (row) location. If there are multiple bad pixels in the same row (Y location is identical for both defective pixels), the listing is in order of increasing X (column) location.

The maximum number of pixels in the BPM list is 4096.

To edit the original BPM file, you need to identify bad pixels, locate and adjust their coordinates, and accurately place pixels' coordinates into the pixel map.

Finding Bad Pixels

To see the bad pixels that are not in the factory BPM:

1. Make sure that *BadPixelCorrection* is set to Factory in the Data Correction menu. The camera corrects the known bad pixels automatically.
2. Set the longest exposure time and slowest frame rate expected.
3. Put the lens cap on the camera.
4. Run the camera for at least 45 minutes at ambient temperature around 18–22 °C or higher.
5. Capture an image (or series of images).
6. Identify all visible bad pixels and add them to the BPM as described in [Locating and adding pixel coordinates](#).

To see all the bad pixels, including those in the factory BPM:

1. Set *BadPixelCorrection* to Off in Data Correction menu.
2. Repeat steps 2–6 of the previous procedure.

Locating and adding pixel coordinates

Follow the steps below to find first pixel coordinates, locate and adjust bad pixel coordinates, and accurately place bad pixel coordinates into the pixel map.

STEP 1: Find the First Pixel Coordinates

Your frame grabber's first pixel coordinates can affect the location accuracy of bad pixel coordinates. So, you must find the image sensor's first pixel coordinates and potentially adjust the bad pixel coordinates based on your findings.

Click the first pixel at the upper most left corner of the screen to find your frame grabber's first pixel X, Y coordinates.

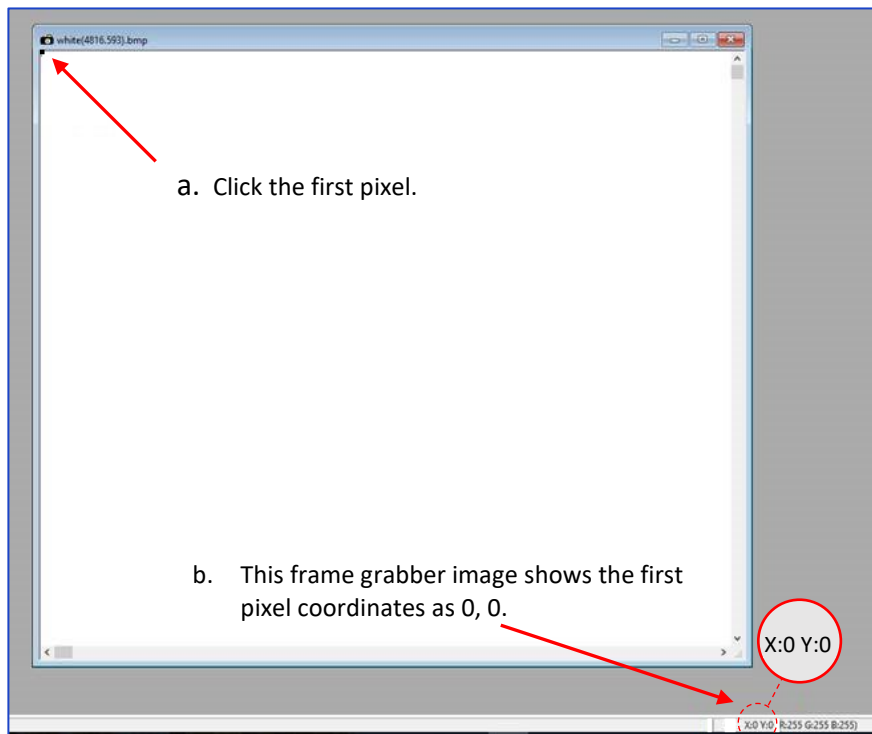

The coordinates will be either 0, 0 or 1, 1:

- If your frame grabber's first pixel coordinates are 0, 0, you should add 1 to both the X and Y coordinates of the bad pixel.
- If the first pixel coordinates are 1, 1, do not add 1 to either coordinate.

STEP 2: Find Defective Pixel Coordinates

Click the bad pixel to find its X, Y coordinates.

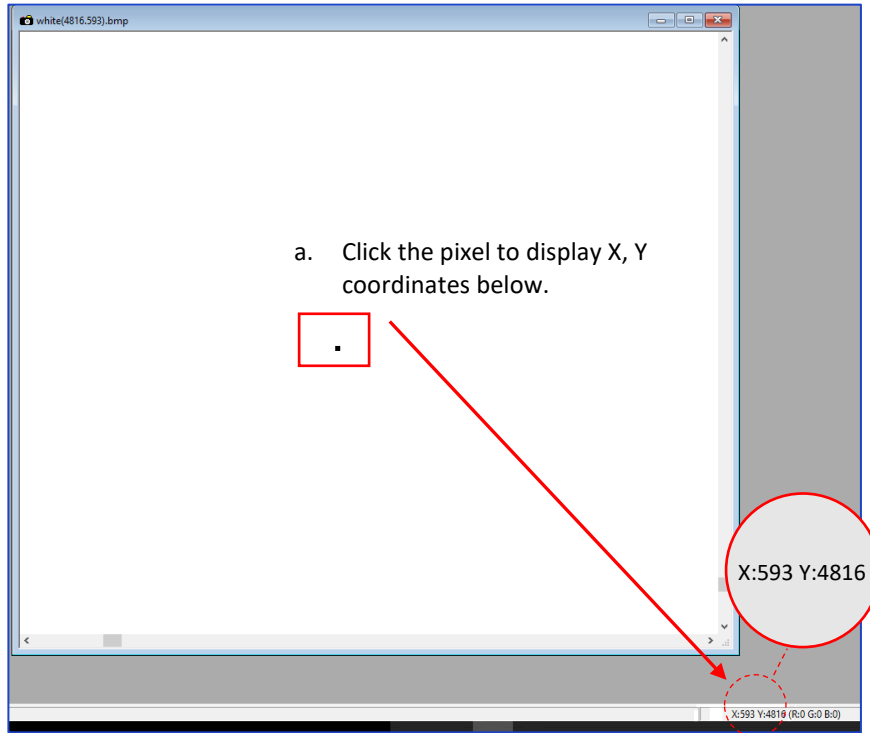

The coordinates are 593, 4816, where X (Column) = 593 and Y (Row) = 4816.

IMPORTANT: Frame grabbers from different manufacturers may display pixel location coordinates in different order, for example:

X (Column), Y (Row) or,
X (Row), Y (Column).

You must put bad pixel coordinates into the pixel correction map file in this order:
X (Column), Y (Row).

If your frame grabber identifies pixel coordinates by X (**Row**), Y (**Column**), you must transpose the coordinates to X (**Column**), Y (**Row**) before entering them into the pixel map files. For example, if the 593, 4816 coordinates in the screen above had been displayed in this order, where X:593 is a row and Y:4816 is a column, you would have had to transpose the coordinates to 4816, 593.

STEP 3: Adjust Defective Pixel Coordinates

As described in **STEP 1**, if the first pixel coordinates are 0, 0, you must adjust the bad pixel coordinates by adding 1 to both coordinates as shown in the following:

$$593 (+1), 4816 (+1) = 594, 4817$$

- If the frame grabber pixel coordinates are Column (X), Row (Y), then go to **STEP 4**.
- If the frame grabber pixel coordinates are Row (X), Column (Y), then transpose the coordinates to the form Column, Row and then go to **STEP 4**.

STEP 4: Add Bad Pixel Coordinates to Bad Pixel Map

Place the bad pixel coordinates in the Bad Pixel Map file in ascending (increasing) numerical order of the Y (row) coordinate. The value of all Y coordinates should progressively increase as you look down the list of X, Y coordinates.

Example 1: Different Y coordinates	Example 2: Identical Y coordinates
<pre>-- Defective Pixel Map, -- Date: 5.18.2020, -- Model#: SFP-C6440M-RF, -- Serial#: LAC001, :Table, -- Column (X) , Row (Y) 701, 1017 100, 1018 4325, 1019 2241, 1020 458, 1021 1712, 1053 914, 1067 3954, 1546 2516, 1670 3451, 3331 1111, 4149 95, 4364 594, 4817 433, 4828</pre> <p>Row coordinates are in ascending order (increasing Y values).</p>	<pre>-- Defective Pixel Map, -- Date: 5.18.2020, -- Model#: SFP-C6440M-RF, -- Serial#: LAC001, :Table, -- Column (X) , Row (Y) 650, 1017 698, 1017 701, 1017 100, 1018 4325, 1019 2241, 1020 458, 1021 1712, 1053 f914, 1067 3954, 1546 2516, 1670 3451, 3331 1111, 4149 95, 4364 433, 4828</pre> <p>Column coordinates are in ascending order (increasing X values).</p>

As shown in the **Example 1** above, the Y coordinate of **594, 4817** is higher than **4364** and lower than **4828**. Do not add defective pixel coordinates at the end of the list unless the Y coordinate is the highest of all Y values.

NOTE * If adding a defective pixel with a Y location identical to one or more other bad pixels, insert its coordinates based on the order of increasing X location.

As shown in the **Example 2** above, the Y coordinate of **698, 1017** is identical to two other bad pixels. Place its coordinates between **650, 1017** and **701, 1017** because its X location (698) is higher than 650 but lower than 701.

STEP 5: Save your BPM

Save your Bad Pixel Map with file extension .bcm.

Creating a BPM Using a Text Editor

You can create your own BPM file using any ASCII text editor, such as Notepad or similar. Alternatively, any spreadsheet program (i.e. Microsoft Excel) can be used by converting the spreadsheet into a comma delimited (.csv) file. In either case, the file must be renamed to include the .bcm file extension. The files look like this:

```
-- Defective Pixel Map,  
-- Date: 5.18.2020,  
-- Model#: POE-C6410M,  
-- Serial#: LAC001,  
:Table,  
-- Column (X) , Row (Y)  
    5683,155  
    3091,332  
    3532,893  
    650,1017  
    701,1017  
    1712,1053  
    914,1067
```

Pixel maps have two main sections: a header and a table. The header section is a free text area of up to 256 ASCII characters. Each line of the header section must be terminated with a comma. The table section of the file contains an array of lines with each line containing an X (column number) value followed by a comma and a Y (row number) value.

All pixels are listed in the BPM in order of increasing Y (row) location. If the Y location is identical, the listing is in order of increasing X (column) location.

The maximum number of pixels in the BPM list is 4096.

To create an BPM file:

1. Identify bad pixels (refer to the sections [Finding Bad Pixels](#)).
IMPORTANT: When creating a new pixel map, you need to get all bad pixels visible. Make sure that the *BadPixelCorrection* is set to Off in the Data Correction menu of the software GUI, so the camera does not correct the known pixel defects.
2. Locate and adjust bad pixels' coordinates (refer to the section [Locating and adding pixel coordinates, STEP1 – STEP3](#)).
3. Place pixels' coordinates into the pixel map and save the file (refer to the section [Locating and adding pixel coordinates STEP4, STEP5](#)).

EXAMPLE

In this example, the first table entry is pixel 4 from row 1, the next entry is pixel 588 from row 1, and the next entry is pixel 78 from row 5, and so on. The file looks like this:

```
:Table,  
-- Column (X) , Row (Y)  
    4,1  
    588,1  
    78,5  
    82,27  
    405,300
```

Creating a BPM Using Imperx Toolkit

1. Set *BadPixelCorrection* to Off in the Data Correction menu.
2. Set the longest exposure time and slowest frame rate expected.
3. Cover a lens with a lens cap or dismount the lens and put on a dust cap on the camera.
4. Run the camera for at least 45 minutes at ambient temperature around 18–22 °C or higher.
5. Capture an image (or series of images) and save it in RAW format.
6. In the IpxToolkit main window, navigate to the saved RAW file(s) and open it.
7. On the **Image Properties** tab:
 - Set **Device Type** to GigE Vision.
 - Set **Width** and **Height** to the RAW image's vertical and horizontal size respectively.
 - Set Pixel Type to the Pixel Format of the RAW image.
The options are Mono8, Mono10, or Mono12 for a monochrome camera and RGB8 for a color camera.
 - For a color camera, select Bayer pattern.
 - Click **Apply**.
8. Select **Tools > DPM/HPM Utility**.
9. On the **Hot** tab, navigate to the saved RAW file(s) and open it.
10. Move the **Threshold** slider to the value that you want to be the minimum luminosity for the bad pixels.
The pixels are treated as hot (bad) if their luminosity is higher than the Threshold limit.
11. Click **Start**.
The hot pixels are added to the **List of Defected Pixels** table.
The maximum number of pixels in HPM is 4096.
12. Fill out the **Camera** and **Serial#** fields and click **Save to File**.
The Upload Utility saves the BPM into an .hpm file.

Uploading a BPM File

After saving the map, you can upload it to the camera using the Imperx **Upload Utility**.

1. Connect and power up your camera.
2. Start the Imperx **Upload Utility** and wait for the Utility to detect the camera. If the utility does not detect the camera, click **Refresh** to restart the device collection.

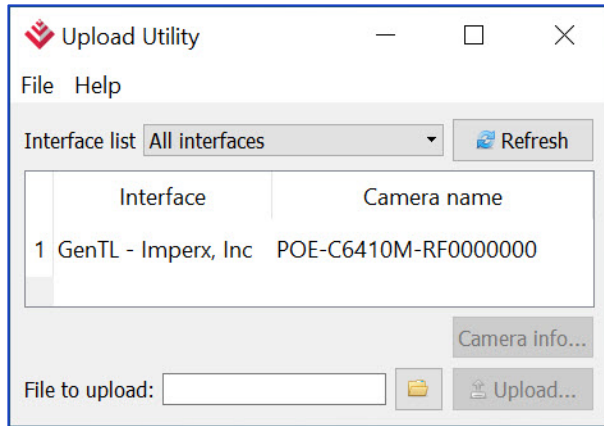

3. Select the camera, click , browse to the edited .bcm or .hpm file, select it, and click **Upload**. Wait for the upload to finish.

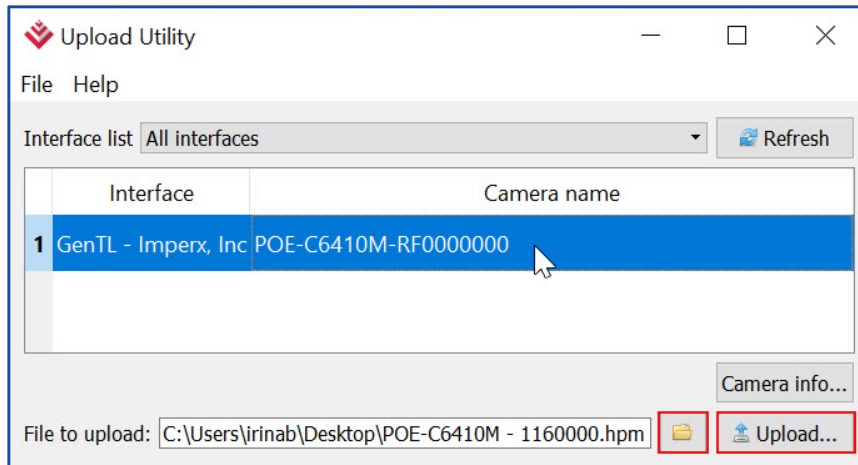

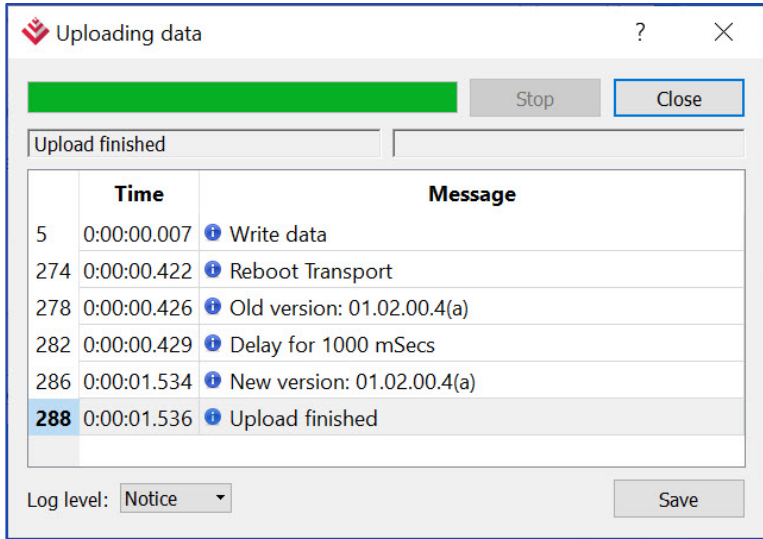

4. After the upload is completed, power cycle the camera.
5. After the camera re-starts, start your software GUI and select **Data Correction**.
6. Make sure that *BadPixelCorrection* is set to **User** so that the camera uses the maps you loaded.

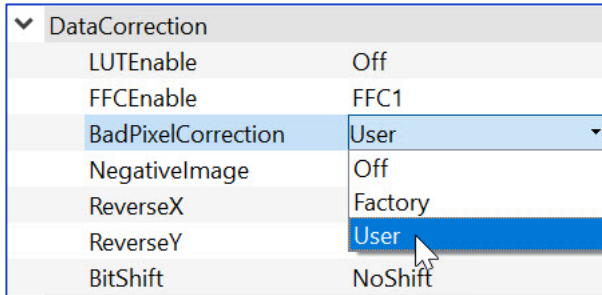

7. Retake images as described in the [Finding Bad Pixels](#) section to make sure that all bad pixels are now corrected.

Appendix C: Look Up Tables

Creating an LUT Using a Text Editor

You can use any ASCII text editor, such as Notepad or similar, to create a custom LUT. Alternatively, any spreadsheet program (i.e. Microsoft Excel) can be used by converting the spreadsheet into a comma delimited (.csv) file. In either case, rename the file to include the .lut file extension.

The .lut file has two main sections: a header and a table. The header section is a free text area of up to 256 ASCII characters. Each line of the header section must be terminated in a comma. The table section of the file contains an array of 4096 lines with each line containing an input value followed by a comma and an output value. The input values represent incoming pixels and the output values represent what each incoming pixel should be converted into as an output pixel.

The format of the .lut file is as follows:

```
-- Look Up Table input file example,  
-- lines beginning with two dashes are comments,  
-- and are ignored by parser,  
:Header,  
-- this is the text that will get displayed with a 'glh' command,  
Function is 'Negative Image',  
Created by John Doe,  
Date 5/28/20,  
:Table,  
-- input output,  
    0,4095  
    1,4094  
    2,4093  
    3,4092  
    4,4091  
    :  
4095,0
```

Creating an LUT Using Microsoft Excel

The LUT file can be created in Excel as follows:

1. Create the spreadsheet as shown below (note that 4096 rows are required in the table).
2. Add the necessary equations into the output cells to generate the transfer function required.
3. Save the file as a .csv (comma delimited format).
4. Rename the .csv file to an extension of .lut.

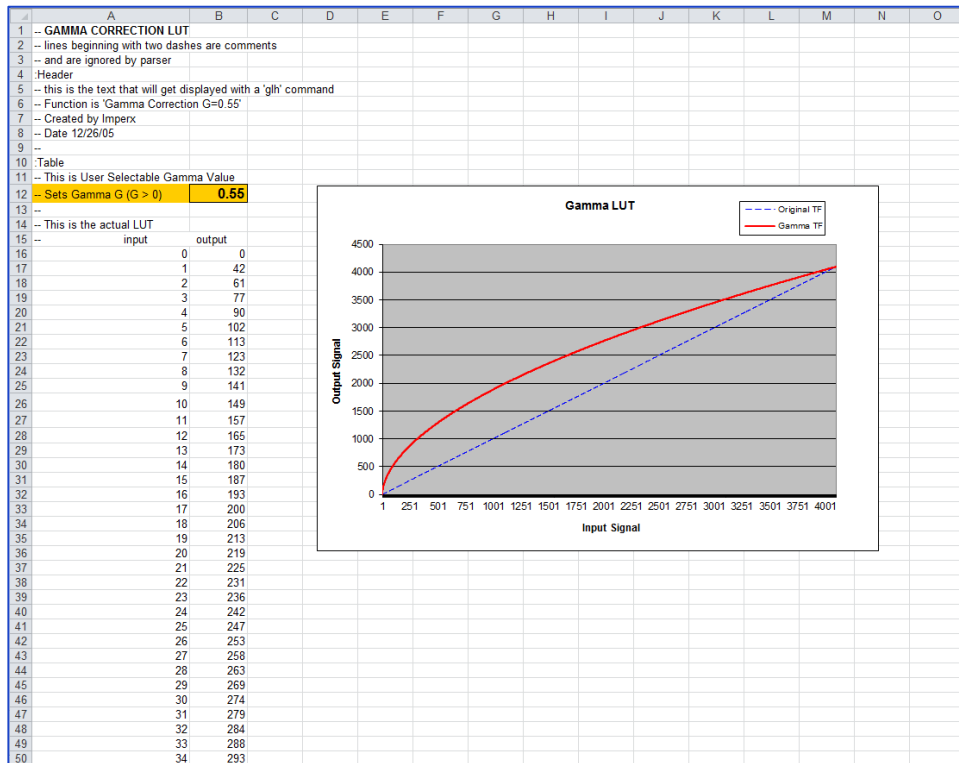

Creating an LUT Using Imperx Toolkit

1. Launch the Imperx Toolkit application. On the Tools tab, open LUT Manager utility.
2. Create a new LUT file. On the Create LUT dialog box, select the LUT type, set the input and output bit depth to 12, and click **OK**.

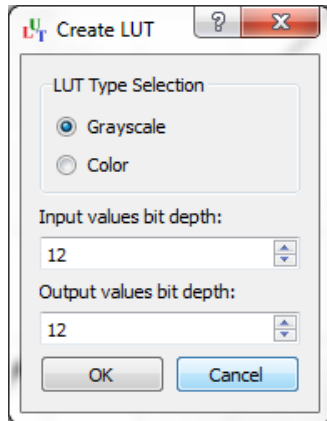

3. Click **Customize** under the LUT plot.
4. Click **More**, set **Curve type** to Dots and **Formula** to User.
5. Type in a formula for the new LUT (see [Example](#) below).
The following operands and operations are available:

Operation	Description	Operator	Description
+	Addition	x	x-value
-	Substraction	pi	Mathematical constant approximately 3.1415926535897932
*	Multiplication		
/	Division		
^	Raise to the power of		
cos()	Cosine function		
sin()	Sine function		
tan()	Tangent function		
acos()	Arc-Cosine function		
asin()	Arc-Sine function		
atan()	Arc-Tangent function		
sqrt()	Square root		
ln()	Log natural		
exp()	Exponent		

6. For a color camera, you can set a transfer function for each channel. Use R, G, and B tabs on the left to switch between the channels.
7. To save the LUT file, go to **File > Save as....**

Example

A modified sigmoid function can be used to enhance low contrast images. The modified sigmoid function is given below:

$$F(x) = \frac{1}{1 + e^{-a(x-b)}}$$

where **x** is the input pixel value.

a is a contrast factor. It determines the steepness of the curve (0.5 – low gain; 10 -high gain).

b is a threshold level. It determines a sigmoid’s midpoint. A midpoint is the brightness of input pixels that is used as a reference. If the brightness of an input pixel is higher than a midpoint, the output pixel value is increased. Otherwise, the output pixel value is decreased.

In the LUT Manager window, type in the following formula under the *Formula* control (with a=4 and b=2):

4095*(1/(1+(exp(-4*(x/(4095/4)-2))))))

The function is scaled so that the input and output pixel values are within the range from 0 to 4095 (for a 12-bit image).

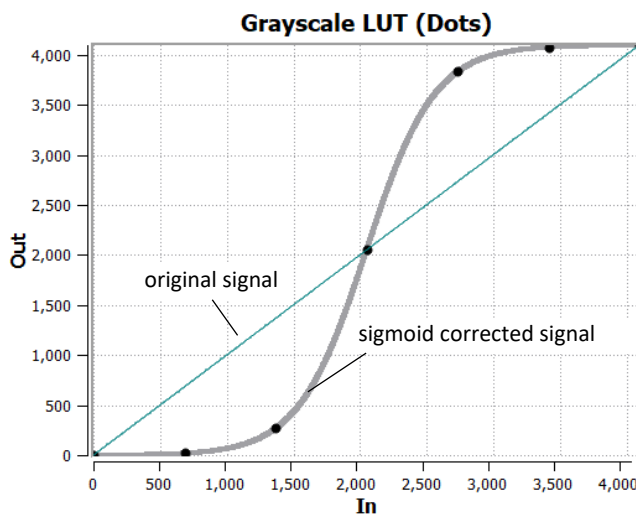

To adjust the overall brightness and contrast of the image, use both threshold and contrast factor parameters. The threshold value controls the amount of brightness, and the contrast factor controls the difference between pixels.

The sigmoid curves with varied threshold and contrast factor parameters are shown below:

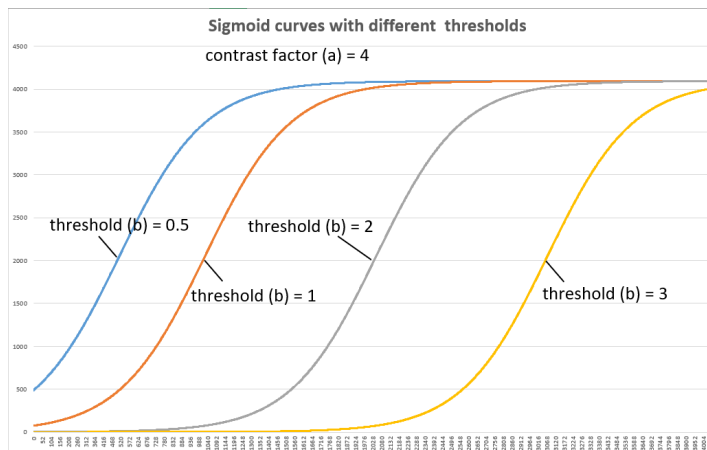
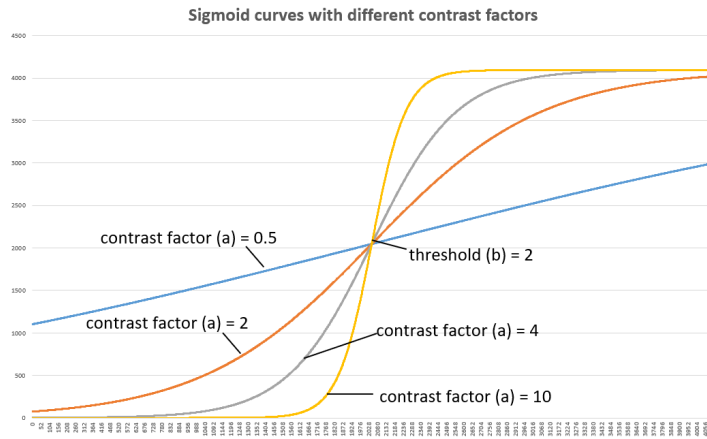

To apply a convex part of the curve within the range from 0 to 4095, use the following formula:

$$2*4095*(1/(1+(exp(-2*(x/(4095/4))))))-0.5$$

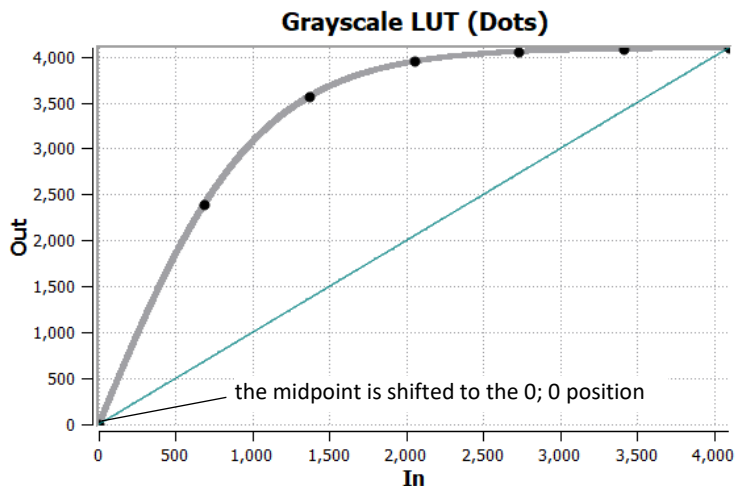

To apply a concave part of the curve within the range from 0 to 4095, use the following formula:

$$2*4095*(1/(1+(\exp(-2*(x/(4095/4)-4))))))$$

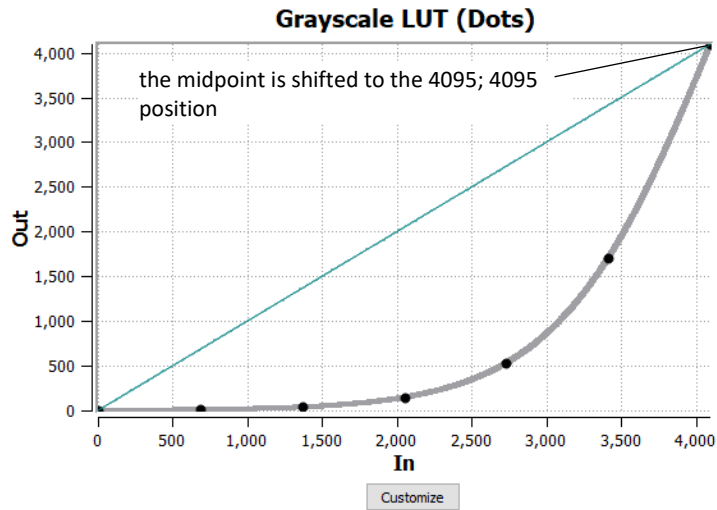



Uploading the LUT File

After saving the LUT into the .lut file, you can upload it into the camera using the Imperx **Upload Utility**.

To upload the LUT file:

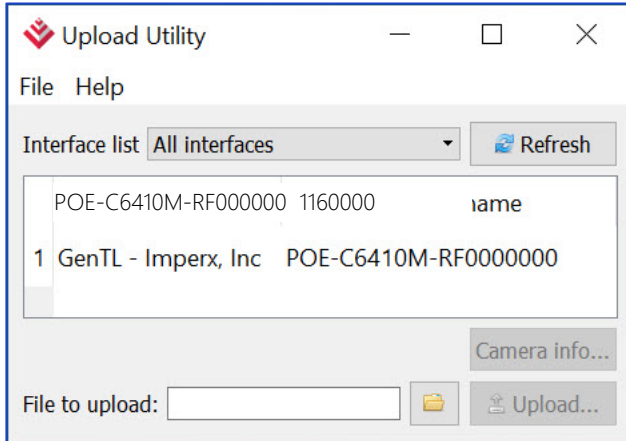
1. Connect and power up your camera.
2. Start the Imperx **Upload Utility** and wait for the Utility to detect the camera. If the utility does not detect the camera, click **Refresh** to restart the device collection.



3. Select the camera, click , browse to the .lut file, select it, and click **Upload**.

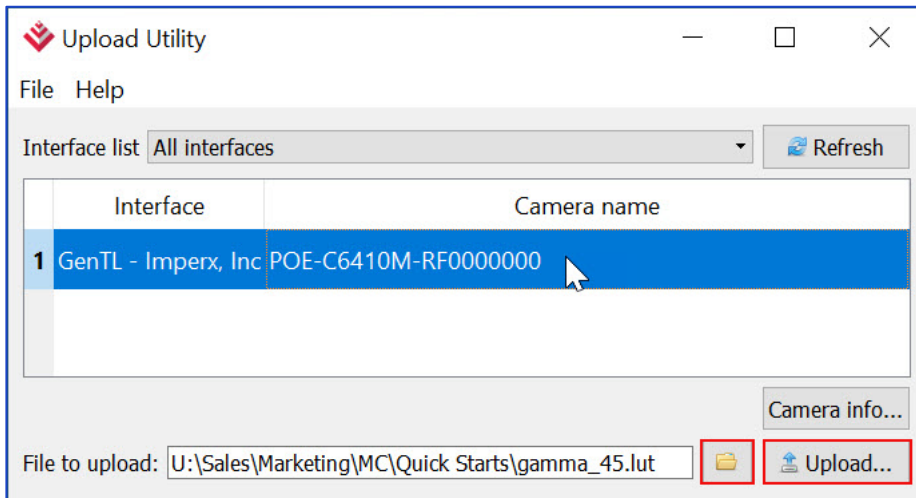

- Select to which camera's User (User1–User4) to upload the .lut file you created and click OK. Wait for the upload to finish.

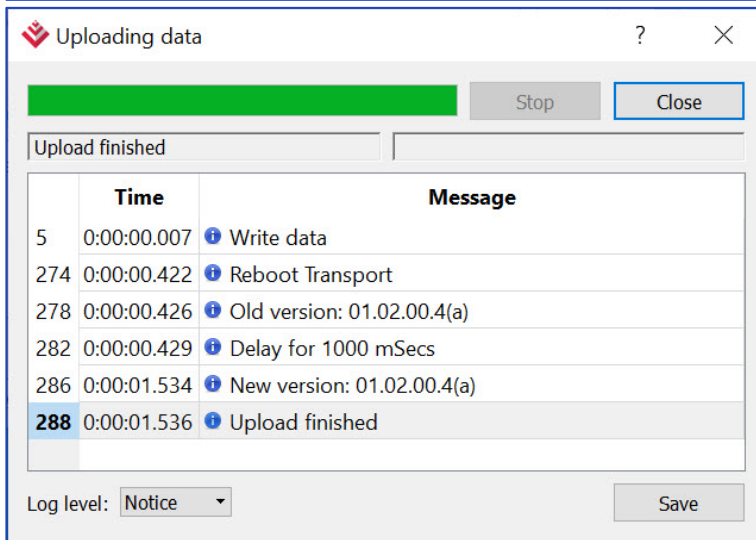
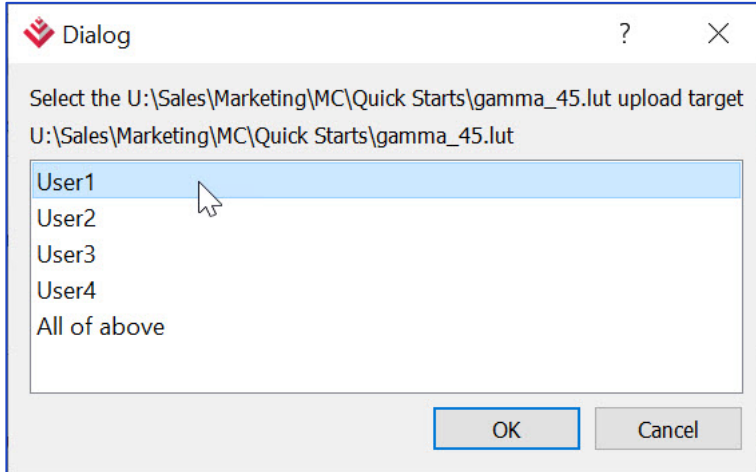

- After the upload is completed, power cycle the camera.
- After the camera re-starts, start the software GUI and select **Data Correction**.
- Set *LUTEnable* to the LUT you uploaded (if you uploaded LUT into User1 then select LUT1, for User2 – LUT2, and so on).
The camera then uses the LUT you uploaded.

